



Cold-Formed Steel Connectors

For Residential and
Mid-Rise Construction

C-CFS10

(800) 999-5099
www.strongtie.com

STRENGTH COMES IN NUMBERS



*Steel Strong-Wall® shearwall cyclic test
Simpson Strong-Tie Tye Gilb test facility
Stockton, CA*

Presenting our Lateral Systems

Little did we know

when we introduced our first holdown in 1966 that our product innovations would lead us to solutions that can help hold together five-story buildings during an earthquake or allow builders to install larger window and door openings in homes. Our offering of lateral-force resisting systems, including Wood and Steel Strong-Wall[®] shearwalls, Anchor Tiedown Systems and new Strong Frame[™] moment frames, give Designers added flexibility when designing wood structures. In addition, our commitment to cold-formed steel construction is illustrated

by our new Steel Strong-Wall and Strong Frame applications, and the possibilities continue to grow.

At Simpson Strong-Tie, we believe that strength really does come in numbers. By offering the largest selection of lab and field-tested lateral-force resisting systems along with dedicated engineers and field support reps to back them up, you can count on the strength of our products and our people to perform.

Whether you're designing or building a single-family home, a six-story mixed-used building or a retail store, we know we have a solution to fit your

project and meet the most stringent code requirements. And we're not done yet. The research, testing and structural system technology that's to come has us just as excited as we were when we developed that first holdown. With each new product and design innovation, we're working with the industry to increase the structural safety of homes and buildings around the country. And in light of all the hurricanes and earthquakes we've experienced during the last 40 years, that's a pretty good feeling.



Steel Strong-Wall[®] shearwalls

Strong Frame[™] moment frames

Anchor Tiedown Systems

To learn more, visit:

www.strongtie.com/lateralsystems



ALPHABETICAL INDEX

ABS Anchor Bolt Stabilizer 16	ICFVL Ledger Connector 38	Roof Slope Conversion 11	Screws 14–15
AHEP Adjustable Hip End Purlin . 60	L Angle 73	S/B Hanger 57	SET-XP Epoxy-Tie Adhesive . . 20–21
AnchorMate ® Bolt Holder 16	LBP Bearing Plate 17	S/BA Hanger 57	SP Stud Plate Tie 66
BP/BPS Bearing Plate 17	LCB Column Base 19	S/DSC Drag Strut Connector . . . 59	SSP Stud Plate 66
CMST Coiled Strap 65	LCE Column Cap 19	S/GTC Girder Truss 61	SSTB Anchor Bolt 27–28
CNW Coupler Nuts 17	LSTA Strap Tie 63–64	S/H Seismic & Hurricane Tie . . . 67	SSWAB Anchor Bolts 50–51
Code Listing Key Chart 8	LSTI Strap Tie 63–64	S/H1A Seismic & Hurricane Tie . . 68	SSWT Template 55
Conversion Charts 11	LT1 Masonry Connector 71	S/HDB Holddown 33	ST Strap Tie 63–64
Corrosion Resistance 12–13	LTB Bridging 59	S/HDS Holddown 33	Standard Steel Thickness 11
CS Coiled Strap 65	LTP Framing Anchor 72	S/HDU Holddown 31	STC, STCT Roof Truss 61
Custom Clips and Angles 74	LTS Twist Strap 62	S/HGAM Masonry Connector . . . 71	STHD Strap Tie Holddown . . . 34–35
DSP Stud Plate Tie 66	MASA Mud sill Anchor 18	S/HJCT Hanger 56	StrapMate ® Strap Holder 16
DTC Double Truss Clips 61	Metric Conversions 11	S/HPAHD Holddown 36	Strong Frame ™ OMF 39
FHA Strap Tie 63–64	MSTA Strap Tie 63–64	S/HTC Heavy Truss Clip 62	TB Bridging 59
GCN Gas Actuated Nailer 23	MSTC Strap Tie 63–64	S/HTT Tension Tie 32	TBD22 Truss Bracing Diagonal . . 60
General Notes 8–11	MSTI Strap Tie 63–64	S/JCT Hanger 56	Titen ® Screw 22
GDP Concrete Pins 23	MTS Twist Strap 62	S/LBV Hanger 57	Titen HD ® Threaded Anchor . . 20, 22
H Seismic & Hurricane Tie . 67–69, 71	MTSM Twist Strap 71	S/LS Skewable Angle 73	TJC37 Jack Truss Connector . . . 59
HPA Purlin Anchor 37	PA Purlin Anchor 37	S/LTT Tension Tie 32	TP Tie Plate 73
HPAHD Holddown 36	PAB/PABH Anchor Bolts 29–30	S/MST Strap Tie 63–64	TPA Tie Plate 73
HRS Strap 63–64	PAF Powder Actuated Fasteners . 24–25	S/PAHD Holddown 36	TSBR Truss Spacer Restraint . . . 60
HSCNW High-Strength Coupler Nut 17	PS Strap 63	S/PSPN Shield Plate 68	TSP Stud Plate 66
HTS Twist Strap 62	PSCA Sheathing Clip 73	S/SSW Shearwall 40–55	VGT Variable Girder Tiedown . . . 70
HTSM Twist Strap 71	PSCL Sheathing Clip 73	S/TSR Truss Spacer Restraint . . 60	W Hanger 58
HTT Tension Tie 32	Quik Drive ® Fasteners 14	S/VGT Variable Girder Tiedown . . 70	WP Hanger 58
HUC Hanger 58	RFB Retrofit Bolt 28	SB Anchor Bolts 26	

HOW TO USE THIS CATALOG

NEW PRODUCTS

New products are shown with the **NEW** symbol. There are also new sizes within existing model series.

EXTRA CORROSION PROTECTION

This icon identifies products that are available with additional corrosion protection (*ZMAX*®, *Hot-Dip Galvanized* or *Stainless Steel*). Check with Simpson Strong-Tie for availability. The end of the product name will indicate what type of extra corrosion protection is provided (*Z* = *ZMAX*, *HDG* = *Hot-Dip Galvanized* or *SS* = *Stainless Steel*). See page 12–13 for information on corrosion. Visit our website www.strongtie.com/info for more technical information on this topic.

HOW WE DETERMINE ALLOWABLE LOADS

Allowable loads in this catalog are determined using calculations and/or one or more of the following methods:

- a minimum of 3 static load tests in CFS assemblies;
- a minimum of 3 static load tests in structural steel jigs;
- a minimum of 3 static load tests of products embedded in concrete or masonry.

Some tests include only portions of a product such as purlin anchor tests—only the embedded hook is tested, not the screwed or bolted section of the strap, which is calculated. Testing to determine allowable loads in this catalog is not done on connection systems in buildings. Testing is conducted in an IAS accredited laboratory. Typically the allowable load is limited to an average test load at 1/8" deflection, an average or lowest test value (*nominal load*) divided by a safety factor or the calculation value. The safety factor is prescribed by Section F1 of the 2001 AISI NAS. For LRFD, the nominal connector strength is multiplied by a resistance factor, also prescribed by Section F1 of the 2001 NAS.

For detailed information regarding how Simpson Strong-Tie tests specific products, contact Simpson Strong-Tie.

Dimensions: This shows the product dimensions (*material thickness, length and width in this case*.) The product drawing includes these callouts as a cross-reference.

Allowable Design Loads: The maximum load imposed on a connection during the life of a structure. There may be multiple design loads acting in different directions (*up, down, lateral, perpendicular, etc.*) imposed on a connection. When connectors are attached to 2 CFS members of different thicknesses, the Designer shall use the thinner of the 2 members for selecting allowable loads.

Model No.: This is the Simpson Strong-Tie product name.

Fasteners: This shows the fastener quantity and type required to achieve the table loads.

Thickness: CFS supporting member thickness to which the product is attached. Allowable Load is based on this CFS supporting member thickness.

Code Ref: See page 8 for the Code Listing Key Chart, to determine which code reports include this product.

Model No.	Connector Material Thick. mil (ga)	L	W	Fasteners			Allowable ASD Tension Loads			Code Ref.
				Rafter/Stud/Joist Thickness			33 mil (20 ga)	43 mil (18 ga)	54 mil (16 ga)	
				33 mil (20 ga)	43 mil (18 ga)	54 mil (16 ga)				
PA18	97 (12 ga)	18½	2½	16- #10	16- #10	8- #10	2830	3685	3685	FC1
PA23		23¾		22- #10	16- #10	8- #10	3685	3685	3685	
PA28		32½		22- #10	16- #10	8- #10	3685	3685	3685	
PA35		35		22- #10	16- #10	8- #10	3685	3685	3685	
HPA28	118 (10 ga)	21½	2½	28- #10	20- #10	10- #10	4845	4845	4845	
HPA35		38½		32- #10	22- #10	12- #10	5420	5420	5420	

OTHER CATALOG DEFINITIONS:

Deflection: The distance a point moves when a load is applied.

Nominal Tension Load (Strength): The capacity of a structure or component to resist the effects of loads, as determined in accordance with 2001 AISI NAS using specified material strengths and dimensions. Typically taken as the average value of at least 3 tests.

The Nominal Tension Load should not be compared against design loads (ASD, LRFD), but used only where the AISI Lateral Design Standard requires the holddown to have nominal tension load (strength) to resist lesser or amplified seismic load or what the system can deliver.

COMPANY PROFILE

The Simpson Strong-Tie Company was founded in Oakland, California and has been manufacturing wood-to-wood and wood-to-concrete connectors since 1956. Since then, Simpson Strong-Tie Company Inc. has grown to be the world's largest manufacturer of construction connectors. In recent years the company's growth has included expanding its product offering to include pre-manufactured shearwalls, anchor systems for concrete and masonry and collated fastening systems, and steel-to-steel connectors since 1994.

The Simpson Strong-Tie Company Inc. "NO EQUAL" program includes:

- Quality products value-engineered for the lowest installed cost at the highest rated performance levels.
- Most thoroughly tested and evaluated products in the industry.
- Strategically-located manufacturing and/or warehouse facilities.
- National Code Agency listings.
- Largest number of patented connectors in the industry.
- International sales team.
- In-house R & D, and tool and die professionals.
- In-house product testing and quality control engineers.
- Member of AITC, ASTM, ASCE, CSI, NBMDA, NLBMDA, SETMA, STAFDA, NFBA, SBCA, Steel Framing Alliance (SFA), Cold Formed Steel Engineer's Institute (CFSEI), Hawaii Pacific Steel Framing Alliance (HSA), Mid-Atlantic Steel Framing Alliance (MASFA), California Steel Framing Alliance (CASFA), American Iron and Steel Institute (AISI's) Committee on Framing Standards, and local organizations.

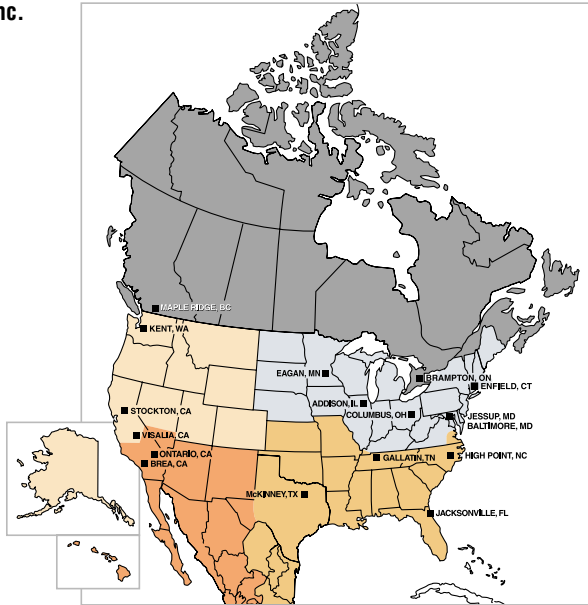

CONNECTOR SELECTION KEY

Products are divided into ten general categories, identified by tabs along the page's outer edge.

Fasteners

14-15 ▶

Concrete Connectors

16-19 ▶

Anchors

20-30 ▶

Holdowns and Tension Ties

31-38 ▶

Lateral Systems

39-55 ▶

Hangers

56-58 ▶

Truss Connectors

59-62 ▶

Straps and Ties and Masonry

63-71 ▶

Miscellaneous

72-73 ▶

Custom Clips and Angles

74 ▶

SIMPSON STRONG-TIE QUALITY POLICY

We help people build safer structures economically. We do this by designing, engineering and manufacturing "No Equal" structural connectors and other related products that meet or exceed our customers' needs and expectations. Everyone is responsible for product quality and is committed to ensuring the effectiveness of the Quality Management System.

Tom Fitzmyers
Chief Executive Officer

Terry Kingsfather
President

GETTING FAST TECHNICAL SUPPORT

When you call for engineering technical support, we can help you quickly if you have the following information at hand. This will help us to serve you promptly and efficiently.

- Which Simpson Strong-Tie catalog are you using? (See the front cover for the form number).
- Which Simpson Strong-Tie product are you using?
- What is your load requirement?
- What is the carried member's thickness, width and height?
- What is the supporting member's thickness, width and height?
- What is the carried and supporting members' material and application?

800-999-5099 | www.strongtie.com

All Rights Reserved. This catalog may not be reproduced in whole or in part without the prior written approval of Simpson Strong-Tie Company Inc.

WE ARE ISO 9001-2000 REGISTERED



Simpson Strong-Tie is an ISO 9001-2000 registered company. ISO 9001-2000 is an internationally-recognized quality assurance system which lets our domestic and international customers know that they can count on the consistent quality of Simpson Strong-Tie's products and services.

NEW PRODUCTS FOR 2010



AHEP Adjustable Hip-End Purlin

The AHEP adjustable purlin is a structural purlin that also serves as an installation aid during the truss erection process. It attaches to the step-down hip trusses at the leading edge eliminating the need for drop-top chords and C-stud fillers. Designed to accommodate a roof-pitch range of 3/12 to 9/12, the AHEP installs linearly, aligned with the end jacks, to maintain sheathing spacing from eave to hip or peak.
Available June 2010.

Page 60



H10S Hurricane Tie

The H10S hurricane tie provides a high-capacity connection from the truss/rafter to the stud or masonry. A flexible fastening pattern allows installation where the stud is offset.

Pages 67 and 69



H2A Hurricane Tie

The new H2A hurricane tie is an improved version of the S/H2 hurricane tie with higher uplift capacity.

Pages 67 and 69



HTT4 and HTT5 Tension Ties

The HTT series of tension ties offers tension-resisting solutions that install with screws. These new additions to the HTT line feature an optimized fastener pattern which results in better performance with less deflection. Designed to meet new code standards, the HTT4 and HTT5 offer higher loads than the S/HTT14.

Page 32



LCE4 Column Cap

The universal design of the LCE provides high capacity while eliminating the need for left and right versions. For use with multiple header thicknesses.

Page 19

NEW PRODUCTS FOR 2010



S/BA Cold-Formed Steel Hanger

The S/BA top-flange hanger is a cost-effective alternative to heavier, special-order hangers. The S/BA is value engineered and tested to achieve higher allowable loads and increased performance. It may be fastened with screws or powder-actuated fasteners or welded to the header, providing more design options and greater versatility.

Page 57



S/TSR Truss Spacer Restraint

The S/TSR truss spacer restraint captures the on-center spacing of cold-formed steel truss chords and webs in linear alignment. The S/TSR laterally restrains the truss members, allowing quicker, easier and safer installations. Its tubular shape provides strength in both compression and tension. S/TSR has a low profile that can be sheathed over, eliminating the need to remove bracing prior to applying the sheathing or decking. **Available June 2010.**

Page 60



S/VGT Variable Girder Tiedown

The S/VGT tiedown is a higher capacity tiedown for girder trusses. It attaches with screws to the side of the truss and features a predeflected crescent washer that allows it to accommodate top chord pitches up to 8/12.

Page 70



Strong Frame® Ordinary Moment Frame

The Strong Frame ordinary moment frame is a cost-effective alternative to traditional frames, which are time intensive to design and labor intensive to install. The Strong Frame ordinary moment frame allows larger openings and smaller wall sections while still providing the loads that structural designers need. Simpson Strong-Tie offers 196 pre-designed solutions and 100% bolted connections to make building with moment frames more convenient than ever.

Page 39



TBD22 Truss Brace

Everything about the new TBD truss brace is designed to make diagonal truss bracing easier. It travels in a box like a coiled strap and is formed into shape as it is pulled from the carton, making it rigid and easy to position across trusses. Once fastened into place, the braces lay flat so that they remain in place as the roof is sheathed, eliminating the need to remove braces. And since the braces stay in place, trusses maintain better alignment and are safer for sheathing crews to work on.

Page 60

IMPORTANT INFORMATION & GENERAL NOTES

Codes

Code Reference Column in Load Tables

The alpha-numeric "Code Reference numbers" that appear in the "Code Reference" column in load tables throughout this catalog are intended to identify products listed in evaluation agency reports, typically called "code reports", and the specific reports that cover them. The letter designates the evaluation agency from which the report was obtained. The Code reference column, used in conjunction with the chart at right, indicates which code listing applies to a product. The reference numbers also clearly identify:

- Products submitted for evaluation report listing (160)
- Products with no evaluation report listing (170)
- Products not submitted because they have no load rating and an evaluation report listing is not necessary (180)
- Products that meet prescriptive or conventional construction code requirements (190)

Where a model has been submitted for listing (160) or does not have an evaluation report listing (170), Simpson Strong-Tie can supply complete test data to support our published loads. Please contact us for a copy of our product test documentation at (800) 999-5099. Product acceptance may be obtained through the Alternate Methods and Materials section of the applicable building code.

Some loads and applications may not be covered in the code report and specific reductions and restrictions may be required by other product evaluation agencies. Visit www.strongtie.com or visit the product evaluation agencies' web sites for the current evaluation reports.

Simpson Strong-Tie® connectors are recognized by most product evaluation agencies. Agencies that recognize some or all of our products include ICC-ES (formerly ICBO, BOCA, SBCCI, NES); IAPMO ES; the City of Los Angeles, California; and State of Florida.

Multiple types of ICC-ES evaluation reports are shown in the Code Reference Key Chart. ICC-ES NER, ICC-ES ER, and ICC-ES ES reports are referred to as Legacy Reports and have been obtained over the years to verify that Simpson Strong-Tie products are in compliance with the code. These Legacy reports were evaluated under the 2000 IBC codes. In order to obtain evaluation for the 2003 or later I-codes, manufacturers must submit for ICC-ES ESR reports.

Simpson Strong-Tie has many ICC-ES ESR reports, but currently not all products have been evaluated to the latest codes. This does not mean that the information in those reports is inaccurate. Simpson Strong-Tie has submitted our Legacy Reports to ICC-ES to obtain product evaluation service reports (ESR's) evaluated to the 2006 IBC/IRC or later editions, but due to the large number of reports they have to evaluate and several new acceptance criteria (AC) that have only recently been adopted, ICC-ES has not been able to process all the reports in time for this catalog.

It is anticipated that in 2010, our remaining Legacy Reports will have been converted. To help understand which of our stamped and welded connector products are listed in an ESR report, we have obtained an ICC-ES index evaluation services report, ICC-ES ESR-2523, for these products. This report is a reference document to other ESR reports held by Simpson Strong-Tie and will be updated frequently by ICC-ES as new stamped and welded connector evaluation services reports are issued or converted. Please visit www.strongtie.com for the latest information or contact ICC Evaluation Services at www.icc-es.org.

IAPMO Evaluation Service has been evaluating products for over 80 years and has the same ANSI accreditation as ICC Evaluation Services for evaluating structural building products to the building codes. IAPMO ES began evaluating structural building products in 2004, utilizing licensed structural engineers to perform quality reviews, and currently are reviewing many other manufacturers' products. Please visit www.strongtie.com for the latest information or contact IAPMO Evaluation Services at www.iapmoes.org.

In November 2007 the Department of State Architecture, California, issued a revised IR 23-1. The Revised Interpretation of Regulation addresses and clarifies issues relating to connectors. IR 23-1 defines the Purpose and Scope and clarifies Listing Requirements, Acceptable Load Capacities, Design Requirements, Installation Requirements and Connector Fabrication which addresses corrosion resistant material and/or coatings. Also, I RA-5 was revised in June of 2008 and is entitled "Acceptance of Products, Materials, and Evaluation Reports. Please contact the DSA at www.dsa.dgs.ca.gov/Publications/default.htm for more information.

On October 1, 2003, the State of Florida's Statewide Product Approval System became effective. The purpose of this system is to provide a single product evaluation and approval system that applies statewide to operate in coordination with the Florida Building Code. This Florida product evaluation and approval system is governed by Florida Statutes, Chapter 553, Section 553.842. Since this law specifies that the product approval system is to apply statewide, Notice of Acceptance are no longer necessary where a product has a statewide approval that is applicable in the High Velocity Hurricane Zone (HVHZ) and is installed in accordance with its conditions of use.

CODE REPORT REFERENCE KEY CHART

AGENCY	CODE REPORT	CODE REF.
ICC-ES LEGACY REPORTS	ER5275	ILC1
City of Los Angeles, CA	RR 25489 RR 25293	LC1 L8
State of Florida	FL9601 FL11470	FC1 F26
Submitted for Listing	Call us for Status and Test Data	160
No Code Listing	Call us for Test Data	170
No Load Rating	—	180
Prescriptive Code	—	190

* As of the printing of this catalog, products coded 160 either have been submitted and are awaiting issuance from the respective product evaluation agency or are to be submitted. Because code reports can be issued throughout the year, we encourage the user to visit www.strongtie.com, www.icc-es.org, www.iapmoes.org, www.ladbs.org, www.dsa.dgs.ca.gov, and www.floridabuilding.org for the most current information, call Simpson Strong-Tie at 800-999-5099, or contact the code agency directly.

IMPORTANT INFORMATION & GENERAL NOTES

WARNING

Simpson Strong-Tie Company Inc. structural connectors, anchors, and other products are designed and tested to provide specified design loads. To obtain optimal performance from Simpson Strong-Tie Company Inc. products and achieve maximum allowable design load, the products must be properly installed and used in accordance with the installation instructions and design limits provided by Simpson Strong-Tie Company Inc. To ensure proper installation and use, designers and installers must carefully read the following General Notes, General Instructions For The Installer and General Instructions For The Designer, as well as consult the applicable catalog pages for specific product installation instructions and notes. Proper product installation requires careful attention to all notes and instructions, including these basic rules:

1. Be familiar with the application and correct use of the connector.
2. Follow all installation instructions provided in the applicable catalog, website, Pocket Installers Guide or any other Simpson Strong-Tie publications.
3. Install all required fasteners per installation instructions provided by Strong-Tie Company Inc.: a) use proper fastener type; b) use proper fastener quantity; c) fill all fastener holes; d) do not overdrive or underdrive nails, including when using gun nailers; and e) ensure screws are completely driven.
4. Only bend products that are specifically designed to be bent. For those products that require bending, do not bend more than once.
5. Cut joists to the correct length, do not "short-cut". The gap between the end of the joist and the header material should be no greater than $\frac{1}{8}$ " unless otherwise noted.

In addition to following the basic rules provided above as well as all notes, warnings and instructions provided in the catalog, installers, designers, engineers and consumers should consult the Simpson Strong-Tie Company Inc. website at www.strongtie.com to obtain additional design and installation information, including:

- Instructional builder/contractor training kits containing an instructional video, an instructor guide and a student guide in both English and Spanish;

- Installer's Pocket Guide (*form S-INSTALL*, contact Simpson Strong-Tie for more information) which is designed specifically for installers and uses detailed graphics and minimal text in both English and Spanish to explain visually how to install many key products;
- Information on workshops Simpson Strong-Tie conducts at various training centers throughout the country;
- Product specific installation videos;
- Specialty catalogs;
- Code reports;
- Technical fliers and bulletins;
- Master format specifications;
- Material safety data sheets;
- Corrosion information;
- Connector selection guides for engineered wood products (*by manufacturer*);
- Simpson Strong-Tie connector selector software;
- Simpson Strong-Tie Autocad menu;
- Simpson Strong-Tie Strong-Wall® Selector software;
- Simpson Strong-Tie Anchor Tiedown System Selector and anchor related software; and
- Answers to frequently asked questions and technical topics.

Failure to follow fully all of the notes and instructions provided by Simpson Strong-Tie Company Inc. may result in improper installation of products. Improperly installed products may not perform to the specifications set forth in this catalog and may reduce a structure's ability to resist the movement, stress, and loading that occurs from gravity loads as well as short-term load even such as wind and earthquake loading. Simpson Strong-Tie Company Inc. does not guarantee the performance or safety of products that are modified, improperly installed or not used in accordance with the design and load limits set forth in this catalog.

These notes are provided to ensure proper installation of Simpson Strong-Tie® products and must be followed fully.

- a. Simpson Strong-Tie Company Inc. reserves the right to change specifications, designs, and models without notice or liability for such changes.
- b. Steel used for each Simpson Strong-Tie product is individually selected based on the product's steel specifications, including strength, thickness, formability, finish, and weldability. Contact Simpson Strong-Tie for steel information on specific products.
- c. Unless otherwise noted, dimensions are in inches, loads are in pounds.
- d. Unless otherwise noted, welds, bolts, screws and nails may not be combined to achieve highest load value.
- e. Catalog loads are based on cold-formed steel members having a minimum yield strength, F_y , of 33 ksi and tensile strength, F_u , of 45 ksi for 43 mils (18 ga) and thinner, and a minimum yield strength, F_y , of 50 ksi and tensile strength, F_u , of 65 ksi for 54 mils (16 ga) and thicker.
- f. Simpson Strong-Tie Company Inc. will manufacture non-catalog products provided prior approval is obtained and an engineering drawing is included with the order. Steel specified on the drawings as $\frac{1}{8}$ ", $\frac{3}{16}$ ", and $\frac{1}{4}$ " will be 11 gauge (0.120"), 7 gauge (0.179"), and 3 gauge (0.239"), respectively. The minimum yield and tensile strengths are 33 ksi and 52 ksi, respectively.
- g. RFB is A307, Grade C; STTB is ASTM A36.
- h. Unless otherwise noted, bending steel in the field may cause fractures at the bend line. Fractured steel will not carry load and must be replaced.
- i. Top flange hangers may cause unevenness. Possible remedies should be evaluated by a professional and include using a face mount hanger or cutting the subfloor to accommodate the top flange thickness.
- j. Built-up members (*multiple members*) must be fastened together to act as one unit to resist the applied load (*excluding the connector fasteners*). This must be determined by the Designer/Engineer of Record.
- k. Do Not Overload. Do not exceed catalog allowable loads, which would jeopardize the connection.
- l. Some model configurations may differ from those shown in this catalog. Contact Simpson Strong-Tie for details.
- m. Some combinations of hanger options are not available. In some cases, combinations of these options may not be installable. Horizontal loads induced by sloped joists must be resisted by other members in the structural system. A qualified designer must always evaluate each connection, including carried and carrying member limitations, before specifying the product. Fill all fastener holes with fastener types specified in the tables, unless otherwise noted. Hanger configurations, height, and fastener schedules may vary from the tables depending on joist size, skew and slope. See the allowable table load for the non-modified hanger, and adjust as indicated. Material thickness may vary from that specified depending on the manufacturing process used. W hangers normally have single stirrups; occasionally, the seat may be welded. S/B, S/LBV, W and WP hangers for sloped seat installations are assumed backed.
- n. Simpson Strong-Tie will calculate the net height for a sloped seat. The customer must provide the H1 joist height before slope.
- o. Do not weld products listed in this catalog unless this publication specifically identifies a product as acceptable for welding, or unless specific approval for welding is provided in writing by Simpson Strong-Tie. Some steels have poor weldability and a tendency to crack when welded. Cracked steel will not carry load and must be replaced.
- p. Steel for the framing members must comply with ASTM A 1003 Grade 33 minimum.
- q. Quik Drive screws have been tested per AISI Standard Test Method TS-04.
- r. Consideration should be given to the screw head specified as this may affect the attached materials.
- s. Do not add fastener holes or otherwise modify Simpson Strong-Tie Company Inc. products. The performance of modified products may be substantially weakened. Simpson Strong-Tie will not warrant or guarantee the performance of such modified products.
- t. All references to bolts or machine bolts (MBs) are for structural quality through bolts (not lag screws or carriage bolts) equal to or better than ASTM Standard A307, Grade A.

Instructions to the Installer

- a. All specified fasteners must be installed according to the instructions in this catalog. Incorrect fastener quantity, size, type, material, or finish may cause the connection to fail.
- b. Holes for $\frac{1}{2}$ " diameter or greater bolts shall be no more than a maximum of $\frac{1}{16}$ " larger than the bolt diameter per 2001 American Iron and Steel Institute North American Specification for the Design of Cold-Formed Steel Structural Members, (AISI NAS) Section E3a.
- c. Install all specified fasteners before loading the connection.
- d. Some hardened fasteners may have premature failure if exposed to moisture. The fasteners are recommended to be used in dry interior applications.
- e. Use proper safety equipment.
- f. When installing a joist into a connector with a seat, the joist shall bear completely on the seat. The gap between the end of the joist and the connector or header shall not exceed $\frac{1}{8}$ " per ICC-ES AC 261 and ASTM D1761 test standards, unless otherwise noted.
- g. For holdowns, anchor bolt nuts should be finger-tight plus $\frac{1}{3}$ to $\frac{1}{2}$ turn with a hand wrench. Care should be taken to not over-torque the nut, impact wrenches should not be used. This may preload the holdown.
- h. All screws shall be installed in accordance with the screw manufacturer's recommendations. All screws shall penetrate and protrude through the attached materials a minimum of 3 full exposed threads per AISI Standard for Cold-Formed Steel Framing – General Provisions Section D1.3.
- i. Welding galvanized steel may produce harmful fumes; follow proper welding procedures and safety precautions. Welding should be in accordance with (AWS) standards. Unless otherwise noted Simpson Strong-Tie connectors cannot be welded.
- j. Temporary lateral support for members may be required during installation.

IMPORTANT INFORMATION & GENERAL NOTES

Instructions to the Designer

- The allowable load is typically limited to an average test load at $\frac{1}{8}$ " deflection, an average or lowest test value (*nominal load*) divided by a safety factor or the calculation value. The safety factor is prescribed by Section F1 of the 2001 AISI NAS.
- Allowable simultaneous loads in more than one direction on a single connector must be evaluated as follows:
Design Uplift/Allowable Uplift + Design Lateral Parallel to Track/Allowable Lateral Parallel to Track + Design Lateral Perpendicular to Track/Allowable Lateral Perpendicular to Track ≤ 1.0 . The three terms in the unity equation are due to the three possible directions that exist to generate force on a hurricane tie. The number of terms that must be considered for simultaneous loading is at the sole discretion of the Designer and is dependant on their method of calculating wind forces and the utilization of the connector within the structural system.
- Loads are based on the 2001 AISI Standard – North American Specification for the Design of Cold-Formed Steel Structural Members (NAS), unless otherwise specified. Other code agencies may use different allowable loads.
- The term "Designer" used throughout this catalog is intended to mean a licensed/certified building design professional, a licensed professional engineer, or a licensed architect.
- All connected members and related elements shall be designed by the Designer.
- Unless otherwise noted, member strength is not considered in the loads given and, therefore, reduce allowable loads when member strength is limiting.
- The average ultimate breaking strength for some models is listed under "nominal tension load".
- Simpson Strong-Tie strongly recommends the following addition to construction drawings and specifications: "Simpson Strong-Tie connectors and fasteners are specifically required to meet the structural calculations of plan. Before substituting another brand, confirm load capacity based on reliable published testing data or calculations. The Engineer/Designer of Record should evaluate and give written approval for substitution prior to installation."
- Verify that the dimensions of the supporting member are sufficient to receive the specified fasteners, and develop the top flange bearing length.
- Simpson Strong-Tie will provide, upon request, code testing data on all products that have been code tested.
- Most of the allowable loads published in this catalog are for use when utilizing the traditional Allowable Stress Design (ASD) methodology. A method for using Load and Resistance Factor Design (LRFD) for cold-formed steel is also included in the 2001 AISI NAS. When designing with LRFD, the nominal connector strength multiplied by the resistance factor must be used. If not listed or noted in a table footnote, contact Simpson for the LRFD values of products listed in this catalog.
- All steel-to-steel connector screws must comply with ASTM C1513.
- Screw strength shall be calculated in accordance to 2001 AISI NAS Section E4 or shall be based upon manufacturers design capacity determined from testing.
- Simpson Strong-Tie recommends that hanger height be at least 60% of joist height for stability.
- Local and/or regional building codes may require meeting special conditions. Building codes often require special inspection of anchors installed in concrete and masonry. For compliance with these requirements, it is necessary to contact the local and/or regional building authority. Except where mandated by code, Simpson's products do not require special inspection.
- When connectors are attached to 2 CFS members of different thicknesses, the Designer shall use the thinner of the 2 members for selecting allowable loads.

Additional Important Information & General Notes for Hybrid (Steel-to-Wood) Connections

These notes are in addition to the previous notes for steel to steel connections and are provided to ensure proper installation of Simpson Strong-Tie® Company Inc. products and must be followed fully.

- Unless otherwise noted, allowable loads are for Douglas Fir-Larch under continuously dry conditions. Allowable loads for other species or conditions must be adjusted according to the code. In many cases, Simpson Strong-Tie code reports will indicate loads derived from Douglas Fir header material only. However under ICC-ES AC13, loads for Douglas Fir are the same as LVL, LSL, PSL, Glulam's and Southern Pine, since the specific gravity of these wood species fall within the specific gravity range of the AC13 criteria. The chart below gives specific gravity for the different wood species as listed by NDS (National Design Specifications). For your convenience we have placed the section from the AC13 criteria indicating the range of specific gravity. 3.2.3 The species of lumber used shall have a specific gravity of, but not greater than 0.55 as determined in accordance with the NDS.
- For face-mount hangers and straight straps, use 0.86 of table loads for Spruce-Pine-Fir.
- A fastener that splits the wood will not take the design load. Evaluate splits to determine if the connection will perform as required. Dry wood may split more easily and should be evaluated as required. If wood tends to split, consider pre-boring holes with diameters not exceeding .75 of the nail diameter (2005 NDS 11.1.5.3).
- Wood shrinks and expands as it loses and gains moisture, particularly perpendicular to its grain. Take wood shrinkage into account when designing and installing connections. Simpson Strong-Tie manufactures products to fit common dry lumber dimensions. If you need a connector with dimensions other than those listed in this catalog, Simpson Strong-Tie may be able to vary connector dimensions; contact the Simpson Strong-Tie. The effects of wood shrinkage are increased in multiple lumber connections, such as floor-to-floor installations. This may result in the vertical rod nuts becoming loose, requiring post-installation tightening.
- Top flange hangers may cause unevenness. Possible remedies should be evaluated by a professional and include using a face mount hanger, and routing the beam or cutting the subfloor to accommodate the top flange thickness.
- Built-up lumber (*multiple members*) must be fastened together to act as one unit to resist the applied load (*excluding the connector fasteners*). This must be determined by the Designer/Engineer of Record.

Species	Fc _⊥	Specific Gravity
Douglas Fir-Larch (DFL)	625 psi	0.50
Southern Pine (SP)	565 psi	0.55
Spruce-Pine-Fir (SPF)	425 psi	0.42
Hem Fir (HF)	405 psi	0.43
Glulam	560 psi	0.50
LVL (DF/SP)	750 psi	0.50
TimberStrand® LSL (E=1.3x106)	680 psi	0.50
TimberStrand® LSL (E>1.5x106)	880 psi	0.50
Parallam® PSL	750 psi	0.50

Additional Instructions for the Installer for Hybrid (Steel-to-Wood) Connections

- Bolt holes into wood members shall be at least a minimum of $\frac{1}{32}$ " and no more than a maximum of $\frac{1}{16}$ " larger than the bolt diameter (per the 2005 NDS 11.1.2.2).
- The joist shall bear completely on the connector seat, and the gap between the joist end and the header shall not exceed $\frac{1}{8}$ " per ICC-ES AC 13 and ASTM D1761 test standards.
- For holdowns, anchor bolt nuts should be finger-tight plus $\frac{1}{8}$ to $\frac{1}{2}$ turn with a hand wrench, with consideration given to possible future wood shrinkage. Care should be taken to not over-torque the nut, impact wrenches should not be used. This may preload the holddown.

Additional Instructions for the Designer for Hybrid (Steel-to-Wood) Connections

- Loads are based on the 2001 AISI Standard - North American Specification for the Design of Cold-Formed Steel Structural Members (NAS) and the 2005 AF&PA National Design Specifications (NDS), unless otherwise specified. Other code agencies may use different allowable loads.
- Duration of load adjustments for fasteners into wood as specified by the code are as follows:
"FLOOR" and "DOWN" (100) — no increase for duration of load.
"SNOW" (115) — 115% of design load for 2 month duration of load.
"ROOF LOAD" (125) — 125% of design load for 7 day duration of load.
"EARTHQUAKE/WIND" (160) — 160% of design load for earthquake/wind loading.
- Some catalog illustrations show connections that could cause cross-grain tension or bending of the wood during loading if not sufficiently reinforced. In this case, mechanical reinforcement should be considered.
- Most of the allowable loads published in this catalog are for use when utilizing the traditional Allowable Stress Design (ASD) methodology. A method for using Load and Resistance Factor Design (LRFD) for cold-formed steel is also included in the 2001 AISI NAS. When designing with LRFD, the nominal connector strength multiplied by the resistance factor must be used. If not listed or noted in a table footnote, contact Simpson for the LRFD values of products listed in this catalog. For more information, refer to the American Forest and Paper Association "Guideline to Pre-engineered Metal Connectors" and ASCE 16. The "Guideline" contains a soft-conversion procedure that can be used to derive reference lateral resistances.
- Simpson Strong-Tie recommends that hanger height be at least 60% of joist height for stability.
- Pneumatic or powder-actuated fasteners may deflect and injure the operator or others. Powder-actuated fasteners should not be used to install connectors. Pneumatic nail tools may be used to install connectors, provided the correct quantity and type of fasteners are properly installed in the fastener holes. Tools with fastener hole-locating mechanisms should be used. Follow the manufacturer's instructions and use the appropriate safety equipment. Over driving fasteners may reduce allowable loads. Contact Simpson Strong-Tie.

IMPORTANT INFORMATION & GENERAL NOTES

Limited Warranty

Simpson Strong-Tie Company Inc. warrants catalog products to be free from defects in material or manufacturing. Simpson Strong-Tie Company Inc. products are further warranted for adequacy of design when used in accordance with design limits in this catalog, and properly specified and installed. This warranty does not apply to uses not in compliance with specific applications and installation procedures set forth in this catalog, or to non-catalog or modified products, or to deterioration due to environmental conditions.

Simpson Strong-Tie® connectors are designed to enable structures to resist the movement, stress and loading that occurs from gravity loads as well as short-term load events such as wind and earthquake loading. Properly-installed Simpson Strong-Tie connectors will perform in accordance with the specifications set forth in the applicable Simpson Strong-Tie catalog. Additional performance limitations for specific products may be listed on the applicable catalog pages.

Due to the particular characteristics of the natural event, the specific design and location of the structure, the building materials used, the quality of construction,

and the condition of the soils involved, damage may nonetheless result to a structure and its contents even if the loads resulting from the natural event do not exceed Simpson Strong-Tie catalog specifications and Simpson Strong-Tie connectors are properly installed in accordance with applicable building codes.

All warranty obligations of Simpson Strong-Tie Company Inc. shall be limited, at the discretion of Simpson Strong-Tie Company Inc., to repair or replacement of the defective part. These remedies shall constitute Simpson Strong-Tie Company Inc.'s sole obligation and sole remedy of purchaser under this warranty. In no event will Simpson Strong-Tie Company Inc. be responsible for incidental, consequential, or special loss or damage, however caused.

This warranty is expressly in lieu of all other warranties, expressed or implied, including warranties of merchantability or fitness for a particular purpose, all such other warranties being hereby expressly excluded. This warranty may change periodically—consult our website www.strongtie.com for current information.

This catalog reflects changes in the allowable loads and configurations of some Simpson Strong-Tie Company Inc. products. This catalog is effective until December 31, 2011, and supersedes all information in all earlier publications, including catalogs, brochures, fliers, technical bulletins, etc. Use this edition as a current reference. Information on allowable loads and configurations may be updated periodically (see www.strongtie.com for the latest information). After December 31, 2011, contact Simpson Strong-Tie for current product information.

Allowable loads in this catalog are for the described specific applications of properly-installed products. Product modifications, improper loading or installation procedures, or deviations from recommended applications will affect connector allowable load-carrying capacities. Connectors are steel and will corrode and lose load-carrying capacity if exposed to ocean salt air, corrosive fire-retardant chemicals, fertilizers, pressure treated lumber, or other substances or environments that adversely affect steel.

Terms & Conditions of Sale

PRODUCT USE

Products in this catalog are designed and manufactured for the specific purposes shown, and should not be used with other connectors not approved by a qualified designer. Modifications to products or changes in installation procedures should only be made by a qualified designer. The performance of such modified products or altered installation procedures is the sole responsibility of the designer.

INDEMNITY

Customers or designers modifying products or installation procedures, or designing non-catalog products for fabrication by Simpson Strong-Tie Company Inc. shall, regardless of specific instructions to the user, indemnify, defend, and hold harmless Simpson Strong-Tie Company Inc. for any and all claimed loss or damage occasioned in whole or in part by non-catalog or modified products.

NON-CATALOG AND MODIFIED PRODUCTS

Consult Simpson Strong-Tie Company Inc. for applications for which there is no catalog product, or for connectors for use in hostile environments, with excessive wood shrinkage, or with abnormal loading or erection requirements.

Non-catalog products must be designed by the customer and will be fabricated by Simpson Strong-Tie in accordance with customer specifications.

Simpson Strong-Tie cannot and does not make any representations regarding the suitability of use or load-carrying capacities of non-catalog products. Simpson Strong-Tie provides no warranty, express or implied, on non-catalog products. F.O.B. Shipping Point unless otherwise specified.

CONVERSION CHARTS

US Standard Steel Gauge Equivalents in Nominal Dimensions

Min. Thick.	Design Thick.	Ref. Ga ²	Thickness of Steel Sheets (in)		
			Uncoated Steel	Galvanized Steel (G90)	ZMAX® (G185)
mils	in				
229	0.2405	3	0.239	—	—
171	0.1795	7	0.179	0.186	—
118	0.1240	10	0.134	0.138	0.140
111	0.1163	11	0.120	0.123	0.125
97	0.1017	12	0.105	0.108	0.110
68	0.0713	14	0.075	0.078	0.080
54	0.0566	16	0.060	0.063	0.065
43	0.0451	18	0.048	0.052	0.054
33	0.0346	20	0.036	0.040	0.042
27	0.0283	22	0.030	0.033	0.035

- Steel thickness may vary according to industry mill standards.
- Gauge numbers shown are for reference only.

Bolt Diameter

in	mm
3/8	9.5
1/2	12.7
5/8	15.9
3/4	19.1
7/8	22.2
1	25.4

Metric Conversion

Imperial	Metric
1 in	25.40 mm
1 ft	0.3048 m
1 lb	4.448N
1 Kip	4.448 kN
1 psi	6895 Pa

mm = millimeter
m = meter
N = newton
kN = kilonewton
Pa = pascal

If Common Rafter Roof Pitch is...

Rise/Run	Slope
1/12	5°
2/12	10°
3/12	14°
4/12	18°
5/12	23°
6/12	27°
7/12	30°
8/12	34°
9/12	37°
10/12	40°
11/12	42°
12/12	45°

Then Hip/Valley Rafter Roof Pitch becomes...

Rise/Run	Slope
1/17	3°
2/17	7°
3/17	10°
4/17	13°
5/17	16°
6/17	19°
7/17	22°
8/17	25°
9/17	28°
10/17	30°
11/17	33°
12/17	35°

- Use these Roof Pitch to Hip/Valley Rafter Roof Pitch conversion tables only for hip/valley rafters that are skewed 45° right or left. All other skews will cause the slope to change from that listed.

CORROSION INFORMATION

Understanding the Issues

Metal connectors, anchors, and fasteners will corrode and may lose load-carrying capacity when installed in corrosive environments or exposed to corrosive materials. There are many environments and materials which may cause corrosion including ocean salt air, fire-retardants, fumes, fertilizers, preservative-treated wood, dissimilar metals, and other corrosive elements.

The many variables present in a single building environment make it impossible to accurately predict if, or when, significant corrosion will begin or reach a critical level. This relative uncertainty makes it crucial that specifiers and users be knowledgeable of the potential risks and select a product coating or metal suitable for the intended use. It is also important that regular maintenance and periodic inspections are performed, especially for outdoor applications.

It is common to see some corrosion on connectors especially in outdoor applications. Even Stainless Steel can corrode. The presence of some corrosion does not mean that load capacity has necessarily been affected or that a failure will occur. If significant corrosion is apparent or suspected, then the wood, fasteners and connectors should be inspected by a professional engineer or general contractor and may need to be replaced.

In the last several years, preservative-treated wood formulations have changed significantly. Many of the new formulations are more corrosive to steel connectors and fasteners than the traditionally used formulation of CCA-C. Simpson Strong-Tie testing has shown that ACQ-C, ACQ-D (Carbonate), CBA-A and CA-B treated woods are approximately 2 times more corrosive than CCA-C, while SBX-DOT (Sodium Borate) treated woods were shown to be less corrosive than CCA-C. Refer to technical bulletin T-PTWOOD for more information.

Due to the many different pressure treatment formulations, fluctuating retention levels, moisture content, and because the formulations may vary regionally, or change without warning, understanding which connectors and fasteners to use with these materials has become a complex task. We have attempted to provide basic knowledge on the subject here, but it is important to fully educate yourself by reviewing our technical bulletins on the topic, and also by viewing information and literature provided by others. Additionally, because the issue is evolving, it is important to get the very latest connector information on the topic by visiting our website at www.strongtie.com/info.

Stainless steel is always the most effective solution to corrosion risk. However, it is also more expensive and sometimes more difficult to obtain. To best serve our customers, Simpson Strong-Tie is evaluating the options to identify the safest and most cost-effective solutions. Based on our testing and experience there are some specific applications that are appropriate for ZMAX®/HDG or G90 connectors (*see chart on page 13.*)

Because increased corrosion from some newer preservative-treated wood is a new issue with little historical data, we have to base our recommendations on the testing and experience we have to date. It is possible that as we learn more, our recommendations may change, but these recommendations are based on the best information we have at this time.

See www.strongtie.com/info for additional critical information.

CORROSION INFORMATION

General Simpson Strong-Tie Recommendations

- Outdoor environments are generally more corrosive to steel. If you choose to use ZMAX or HDG on an outdoor project (*i.e. deck, patio cover*), you should periodically inspect your connectors and fasteners or have a professional inspection performed. Regular maintenance including water-proofing of the wood used in your outdoor project is also a good practice.
 - For wood with actual retention levels greater than 0.40 pcf for ACQ and MCQ, 0.41 pcf for CBA-A, or 0.21 pcf for CA-B (*Ground Contact*), Stainless Steel connectors and fasteners are recommended. Verify actual retention level with the wood treater.
 - When using Stainless Steel connectors, use Stainless Steel fasteners. When using ZMAX/HDG galvanized connectors, use fasteners that meet the specifications of ASTM A153.
 - Testing indicates wood installed dry reduces potential corrosion. If dry wood is used, see our website for additional information.
 - Using a barrier membrane can provide additional corrosion protection, see Technical Bulletin T-PTBARRIER.
- Due to the many variables involved, Simpson Strong-Tie cannot provide estimates on service life of connectors, anchors or fasteners. We suggest that all users and specifiers also obtain recommendations for HDG, ZMAX (G185), mechanically galvanized, or other coatings from the treated wood supplier for the type of wood used. However, as long as the Simpson Strong-Tie recommendations are followed, Simpson Strong-Tie stands behind its product performance and our standard warranty (*page 11*) applies.

Guidelines for Selecting the Proper Connector

1 Evaluate the Application.

Consider the type of structure and how it will be used. These recommendations may not apply to non-structural applications such as fences.

2 Evaluate the Environment.

Testing and experience indicate that indoor dry environments are less corrosive than outdoor environments. Determining the type of environment where a connector or fastener will be used is an important factor in selecting the most appropriate material and finish for use on the connectors and fasteners. To help in your decision making, consider the following general exposure information:

Interior Dry Use: Includes wall and ceiling cavities, and raised floor applications of enclosed buildings that have been designed to ensure that condensation and other sources of moisture do not develop.

Exterior – Dry: Includes outdoor installations in low rainfall environments and no regular exposure to moisture.

Exterior – Wet: Includes outdoor installations in higher moisture and rainfall environments.

Higher Exposure Use: Includes exposure to ocean salt air, fire retardants, large bodies of water, fumes, fertilizers, soil, some preservative treated woods, industrial zones, acid rain, and other corrosive elements.

3 Evaluate and select a suitable pressure-treated wood for the intended application and environment.

The treated wood supplier should provide all the information needed regarding the wood being used. This information should include: the specific type of wood treatment used, if ammonia was used in the treatment, and the chemical retention level. If the needed information is not provided then Simpson Strong-Tie would recommend the use of Stainless Steel connectors and fasteners. You should also ask the treated wood supplier for a connector coating or material recommendation.

4 Use the chart on the right, which was created based on Simpson Strong-Tie testing and experience to select the connector finish or material.

If a pressure treated wood product is not identified on the chart, Simpson Strong-Tie has not evaluated test results regarding such product and therefore cannot make any recommendation other than the use of Stainless Steel with that product. Manufacturers may independently provide test results or other product use information; Simpson Strong-Tie expresses no opinion regarding any such information.

5 Compare the treated wood supplier's recommendation with the Simpson Strong-Tie recommendation.

If these recommendations are different, Simpson Strong-Tie recommends that the most conservative recommendation be followed.

Low = Use Simpson Strong-Tie standard painted and G90 galvanized connectors as a minimum.

Med = Use ZMAX/HDG galvanized connectors as a minimum. Use fasteners which meet the specifications of ASTM A153 or SDS screws with double-barrier coating.

High = Use Type 303, 304, 305 or 316 Stainless Steel connectors and fasteners.

CONNECTOR COATING RECOMMENDATION – STRUCTURAL APPLICATIONS

Environment	Untreated Wood	SBX/ DOT & Zinc Borate	MCQ	ACQ-C, ACQ-D (Carbonate), CA-B & CBA-A			ACZA	Other or Uncertain
				No Ammonia	With Ammonia	Higher Chemical Content ¹		
Interior – Dry	Low	Low	Low ⁵	Med ⁵	Med	High	High	High
Exterior – Dry	Low	N/A ²	Med	Med	High	High	High	High
Exterior – Wet	Med	N/A ²	Med ^{3,4}	Med ^{3,4}	High	High	High	High
Higher Exposure	High	N/A ²	High	High	High	High	High	High
Uncertain	High	N/A ²	High	High	High	High	High	High

- Woods with actual retention levels greater than 0.40 pcf for ACQ and MCQ, 0.41 pcf for CBA-A, or 0.21 pcf for CA-B (*Ground Contact* level).
- Borate treated woods are not appropriate for outdoor use.
- Test results indicate that ZMAX/HDG and the SDS double-barrier coating will perform adequately, subject to regular maintenance and periodic inspection. However, the nationally-approved test method used, AWPA E12-94, is an accelerated test, so data over an extended period of time is not available. If uncertain, use stainless steel.
- Some treated wood may have excess surface chemicals making it potentially more corrosive. If you suspect this or are uncertain, use stainless steel.
- Where noted in the table, applications where the wood is dry (moisture content less than 19%) when installed and will remain dry in-service may use a minimum coating recommendation of "Low".
- Type 316 stainless-steel connectors and fasteners are the minimum recommendation for ocean-salt air and other chloride environments.

COATINGS AVAILABLE Not all products are available in all finishes. Contact Simpson Strong-Tie for product availability, ordering information and lead times.

Finish	Description	Level of Corrosion Resistance
Gray Paint	Water-based paint intended to protect the product while it is warehoused and in transit to the jobsite.	Low
Powder Coating	Baked on paint finish that is more durable than our standard paint and produces a better looking finished product.	Low
Standard G90 Zinc Coating	Zinc galvanized finish containing 0.90 oz. of zinc per square foot of surface area (total both sides).	Low
ZMAX G185	Galvanized (G185) 1.85 oz. of zinc per square foot of surface area (<i>hot-dip galvanized per ASTM A653 total both sides</i>). These products require hot-dip galvanized fasteners (<i>fasteners which meet the specifications of ASTM A153</i>).	Medium
HOT-DIP HDG GALVANIZED	Products are hot-dip galvanized after fabrication 68 MIL (14 ga.) and thicker. The coating weight increases with material thickness. The minimum specified coating weight is 2.0 oz./ft ² (<i>per ASTM A123 total both sides</i>). These products require hot-dip galvanized fasteners (<i>fasteners which meet the specifications of ASTM A153</i>).	Medium
Double-Barrier Coating (SDS Screws)	SDS screws that are manufactured with two different finishes that provide a level of corrosion protection that is equivalent to that provided by the previous HDG finish.	Medium
SS316 STAINLESS STEEL	Products manufactured from Type 316L stainless steel, and provide greater durability against corrosion. Stainless steel nails are required with stainless steel products, and are available from Simpson Strong-Tie.	High

See Corrosion Information for more specific performance and application information on these finishes.

QUIK DRIVE® Auto-Feed Screw Driving Systems

Quik Drive auto-feed screw driving systems offer a labor saving method for installing specialty fasteners engineered for a wide range of cold-formed steel commercial and residential construction applications.

The systems offer several easy-to-use attachments that bring speed and reliability to applications that require the fastening power of screws.

Featuring patented collation technology, Quik Drive fasteners are designed to meet or exceed industry standards for strength and longevity while offering easy-to-load strips for efficient performance in auto-feed systems.

Some applications include:

- Subflooring, sheathing, wallplates and stairtreads
- Decks and docks
- Drywall
- Fiber cement siding and backerboard
- Composite or wood underlayment
- Metal roofing and siding
- Tile roofing
- Steel to steel

See www.strongtie.com or Quik Drive® catalog C-QD08 for more detailed information.

Quik Drive Screw Strength

Model No.	Screw Size	Nominal Strength		Load Resistance Factor Design (LRFD)		Allowable Stress Design (ASD)	
		Shear	Tension	Shear	Tension	Shear	Tension
		P_{ss}	P_{ts}	ΦP_{ss}	ΦP_{ts}	P_{ss}/Ω	P_{ts}/Ω
Steel to Steel							
PHSD34S0818	#8 x 3/4"	1495	1810	750	905	500	605
TRSD34S1016	#10 x 3/4"	1885	2120	945	1060	630	705
X1S1016	#10 x 1"	1835	2885	920	1145	610	960
XQ1S1016	#10 x 1"	1835	2885	920	1145	610	960
X1S1214	#12 x 1"	2485	4045	1240	2020	830	1350
XQ1S1214	#12 x 1"	2485	4045	1240	2020	830	1350
Steel Decking							
X78S1224	#12 x 7/8"	2665	4680	-	-	-	-
XQ78S1224	#12 x 7/8"	2800	4260	1400	2130	935	1420
XQ114S1224	#12 x 1 1/4"	2800	4260	1400	2130	935	1420
XQ112S1224	#12 x 1 1/2"	2800	4260	1400	2130	935	1420
Metal-Roofing Clip to Steel							
PCSD1S1016	#10 x 1"	1705	2380	850	1190	570	795
PCSD1S1214	#12 x 1"	1760	3180	880	1590	585	1060
Metal-Roofing Clip to Wood							
PC1BS1012	#10-12 x 1"	1415	2080	710	1040	470	695
PC1BS1211	#12-11 x 1"	1715	3080	860	1540	570	1025
PCULP1BS1012	#10-12 x 1"	1625	2275	815	1140	540	760
Drywall							
DWF114PS	#6 x 1 1/4"	1255	1575	630	790	420	525
DWF158PS	#6 x 1 1/2"	1255	1575	630	790	420	525
DWFSD114PS	#6 x 1 1/4"	1260	1720	630	860	420	575
DWFSD158PS	#6 x 1 1/2"	1260	1720	630	860	420	575
Fiber Cement Board							
CB3BLG112S	#10 x 1 1/2"	1515	2045	755	1020	505	680
CB3BLG134S	#10 x 1 3/4"	1540	2030	770	1015	515	675
Wood to Steel							
PPSD11516S	#8 x 1 1/4"	1565	2160	785	1080	520	720

1. Quik Drive screws have been tested per AISI Standard Test Method TS-04.
2. Factor of Safety (Ω), and Resistance Factor (Φ) are determined per 2001 AISI NAS & 2004 NAS Supplement Chapter F.
3. P_{ss} and P_{ts} are nominal shear strength and nominal tension strength values for the screw itself respectively and are also known as the average (ultimate) values of all tests determined by independent laboratory testing.

Screws for Cold-Formed Steel
X Series

#12 and #10 hex head screws, 5/16" drive

X1S1214

(Blue Zinc)
12 x 1" (25mm)
#3 drill point, 14 tpi

XQ1S1214

(QuikGuard)
12 x 1" (25mm)
#3 drill point, 14 tpi

X1S1016

(Blue Zinc)
10 x 1" (25mm)
#3 drill point, 16 tpi

XQ1S1016

(QuikGuard)
10 x 1" (25mm)
#3 drill point, 16 tpi

X78S1224

(Climaseal®)
12 x 7/8" (21mm)
#4 drill point, 24 tpi
ER-1976

XQ78S1224

(QuikGuard)
12 x 7/8" (21mm)
#4 drill point, 24 tpi

XQ114S1224

(QuikGuard)
12 x 1 1/4" (32 mm)
#5 drill point, 24 tpi

XQ112S1224

(QuikGuard)
12 x 1 1/2" (38 mm)
#5 drill point, 24 tpi

TRSD Series

#10 screw, #3 drill point, truss head, clear zinc coating.



TRSD34S1016
3/4" (19mm)

PHSD Series

#8 screw, #2 drill point, pan head, clear zinc coating.



PHSD34S0818
3/4" (19mm)

Screws for Other Applications
DWF Series

#6 drywall screw, fine thread, sharp point, bugle head, gray phosphate finish.

DWF114PS

1 1/4" (32mm)

DWF158PS

1 5/8" (41mm)

CB3BLG Series

#10 fiber cement board screw, coarse thread, type 17 point, bugle head, C3 mechanical galvanized corrosion protection.

CB3BLG134S

1 3/4" (45mm)

CB3BLG112S

1 1/2" (38mm)

DWF and CB3BLG Series for application attaching to CFS with thickness of 33-18 mil (20-25 ga).

PC Series

#10 and #12 metal roofing-to-wood, #2 square drive – BIT2S, coarse threads, type 17 point, pancake head, clear zinc coating

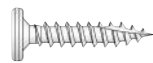
PC1BS1012

(Clear Zinc)

10 x 1" (25 mm)

Type 17 point, 12 tpi

PC1BS1211

(Clear Zinc)

12 x 1" (25 mm)

Type 17 point, 11 tpi

PCULP Series

#10 metal roofing-to-wood, #2 square drive – BIT2S, coarse threads, type 17 point, ultra-low profile pancake head, clear zinc coating

PCULP1BS1012

(Clear Zinc)

10 x 1" (25 mm)

Type 17 point, 12 tpi

PCSD Series

#10 and #12 metal roofing-to-steel, #2 square drive – BIT2S, coarse threads, drill point, pancake head, available in clear zinc and Quik Guard® coatings.

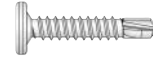
PCSD1S1016

(Clear Zinc)

10 x 1"

#3 drill point, 16 tpi

PCSDQ1S1016

(QuikGuard)

10 x 1"

#3 drill point, 16 tpi

PCSD1S1214

(Clear Zinc)

12 x 1"

#3 drill point, 14 tpi

PCSDQ1S1214

(QuikGuard)

12 x 1"

#3 drill point, 14 tpi

DWFSD Series

#6 drywall screw, fine thread, #2 drill point, bugle head, yellow zinc coating.

DWFSD158PS

1 5/8" (41mm)

DWFSD114PS /

DWFZSD114PS

(clear zinc coating)

1 1/4" (32mm)

ER-5623

DWFSD114PS

(N2000 Coating)

1 1/4" (32mm)

PPSD Series

#8 wood to steel screw, #2 drill point, flat head, yellow zinc coating.

PPSD11516S

1 5/16" (49mm)

DWFSD and PPSD Series for application attaching to CFS with thickness of 54-43 mil (16-18 ga).

Design values for shearwalls and diaphragms built with the PPSD, DWF or DWFSD series screws used to attach the structural sheathing to the framing; and in accordance with the AISI Lateral Standard are found in shearwall Tables C2.2-1 to C2.1-3 and diaphragm Table D2.1 of that document

QUIK DRIVE® Auto-Feed Screw Driving Systems

Quik Drive Fasteners: Minimum Coating or Material Recommendation

Environment	Untreated	SBX/DOT & Zinc Borate	MCQ	ACQ-C, ACQ-D, CA-B, CBA-A		
				w/o Ammonia	w/ Ammonia	Higher Chemical Content
Interior Dry	Low	Low	Low	Med	Med	High
Exterior	Med	N/A	Med	Med	High	High
Higher Exposure	High	N/A	High	High	High	High

Low – Heavy zinc electroplate, yellow zinc dichromate, gray phosphate, C-3 mechanically galvanized, Climaseal®, TufCote®, clear zinc, 410 stainless steel

Med – N2000®, Quik Guard®

High – 305/316 stainless steel

- Use 305/316 stainless steel with any treatment chemical not listed above or in uncertain environmental exposure conditions.
- For wood with actual retention levels higher than 0.10 pcf (above ground) for CA-B and 0.20 pcf for CBA-A, or 0.25 pcf (above ground) for ACQ-D, ACQ-C and MCQ 305/316 stainless steel fasteners are recommended. Verify actual retention level with wood treater.
- Borate treated woods are not appropriate for outdoor use.
- Test results indicate that N2000 and Quik Guard will perform adequately, subject to regular maintenance and periodic inspection. However, the test protocol followed was a modified version of the nationally recognized test method AWPA E12-94. This test method is an accelerated test, so data over an extended period of time is not available. Also noteworthy is that tests run in a laboratory may not correlate to service conditions. If uncertain, use 305/316 stainless steel.
- Some treated wood may have excess surface chemicals making it potentially more corrosive. If you suspect this or are uncertain, use 305/316 stainless steel.
- Ammonia is typically used as a chemical carrier for difficult to treat wood species, such as, but not exclusive to, Douglas Fir and Hem Fir, which are usually found in the Western United States. Amine carriers are used in some of the Eastern species, such as Southern Yellow Pine. If uncertain, verify chemical chemical with wood treater.

For the latest Simpson Strong-Tie® Quik Drive coating information and additional technical information on this topic, visit our website at www.strongtie.com/info.

SCREWS Self-Drilling Fasteners

To achieve the loads shown in this catalog, the Designer must verify that the self-tapping screws used have an allowable load capacity equal to or greater than those shown in the table below.

Hex head screw sizes shown are required for connectors in this catalog. Where sheathing or finishes will be applied over the screws and low profile heads are needed, such as with bracing connectors, hurricane ties, and stud-plate ties, the Designer is to ensure that the minimum screw head diameter complies with ASME B18.6.4.

#8 x 3/4"

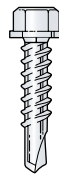

#10 x 3/4"

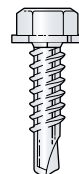

#14 x 1"

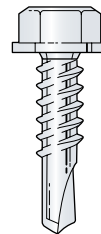

Shown
Actual Size

Minimum ASD Loads for C-CFS10 Connector Screws

Screw No. Designation	Nominal Diameter d ⁴	Washer Diameter d _w	P _{ss} /Ω	Shear					P _{ts} /Ω	Tension				
				Shear (P _{ns} /Ω, P _{ss} /Ω)						Tension: Pull-Out (P _{not} /Ω, P _{ts} /Ω)				
				Steel Thickness: mil (ga)						Steel Thickness: mil (ga)				
				33-33 (20-20)	43-43 (18-18)	54-54 (16-16)	68-68 (14-14)	97-97 (12-12)		33 (20)	43 (18)	54 (16)	68 (14)	97 (12)
#8	0.164	0.318	335	165	245	335	335	—	655	70	95	145	150	—
#10	0.190	0.375	555	175	265	535	555	555	880	85	110	180	220	355
#14 ⁷	0.242	0.500	810	200	295	605	810	810	1225	80	140	185	200	320

- The tabulated loads may be multiplied by a Factor of Safety (Ω) of 3 to determine the screw nominal strength. The LRFD load may be determined by multiplying the nominal screw load by a Resistance Factor (Φ) of 0.50.
- Self-tapping screw fasteners for steel-to-steel connections used for connectors in this catalog shall be in compliance with ASTM C1513.
- Values are based on cold-formed steel (CFS) members with a minimum yield strength, F_y, of 33 ksi and tensile strength, F_u of 45 ksi for 43 mils (18 ga) and thinner and a minimum yield strength of 50 ksi and tension strength of 65 ksi for 54 mils (16 ga) and thicker.
- Minimum base metal thickness is based on AISI General Provisions Standard Table A5.1-1. Design thickness shall be the minimum base metal thickness divided by 0.95. Design thickness for the steel sheets are: 33 mil=0.0346", 43 mil=0.0451", 44 mil=0.0566", 68 mil = 0.0713", and 97 mil = 0.1017".
- Minimum required screw length is the greater of 3/4" and the minimum length required for the screw to extend through the steel connection a minimum of (3) exposed threads per AISI General Provisions Standard Section D1.3.
- Screw diameters per 2001 AISI NAS Commentary Table C-E4-1.
- 1/4" self-tapping screws may be substituted for #14 screws.

ANCHORMATE® Anchor Bolt Holders

Designed to hold the anchor in place before the concrete pour, as required in some jurisdictions.

FEATURES:

- Built-in 2x4 and 2x6 stops eliminate measuring.
- Elevated bolt grippers allow easy trowel finishing.
- Color-coded for easy size identification.
- Lightweight, durable and easy to use.
- Reusable yet cost-efficient for single application.
- Threaded grippers hold each bolt in the exact same location and height. They secure the bolt in place without a nut for quicker set-up and tear-down, and protect threads from splashing concrete.
- Use the 5/8" and 7/8" AnchorMate to secure the anchor bolt to the formboard before the concrete pour. Alignment arrows (left or right) match the anchor bolt head arrow.
- Available in cartons of 100 parts or bags of 10 parts.

MATERIAL: Nylon

CODES: See page 8 for Code Listing Key Chart.

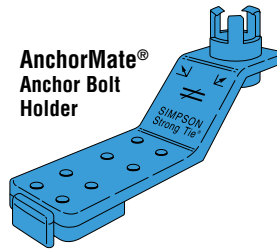

Model No.	Dia.	Color	Code Ref.
AM½	½	Yellow	180
AM⅝	⅝	Blue	
AM¾	¾	Red	
AM⅞	⅞	Green	

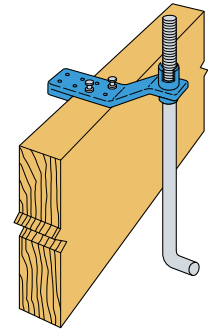
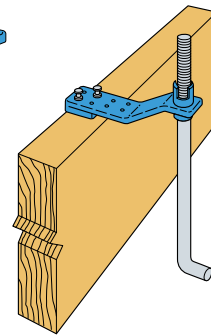

ABS Anchor Bolt Stabilizer

The ABS stabilizes the anchor bolt to prevent it from being pushed against the form during the concrete pour.

FEATURES:

- Supports the bolt approx. 8" below the top of the concrete.
- Model ABS⅝ is for the 5/8" anchor bolts and ABS⅞ is for 7/8" anchor bolts.
- Thin section limits the effect of a cold joint.
- Sized for 2x4 and 2x6 mudsills.

MATERIAL: Engineered Composite Plastic.

CODES: See page 8 for Code Listing Key Chart.

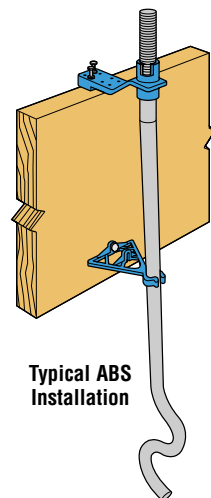
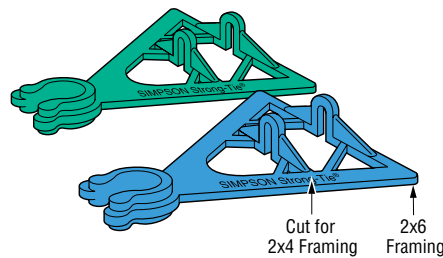

Model No.	Diameter	Color	Code Ref.
ABS⅝	⅝	Blue	180
ABS⅞	⅞	Green	

STRAPMATE® Strap Holder

The StrapMate is designed to keep the STHD, S/HPAHD and S/PAHD straps vertically aligned during the concrete pour to minimize possibility of spalling. The friction fit allows for quick and easy installation.

FEATURES:

- The StrapMate is reusable.
- Works with STHD, S/HPAHD, S/PAHD.

MATERIAL: Engineered Composite Plastic

- Designed to fit 3/4" plywood forms up to 1 3/4" LVL forms and larger.
- The strap is positioned off the front edge of the form board.

CODES: See page 8 for Code Listing Key Chart.

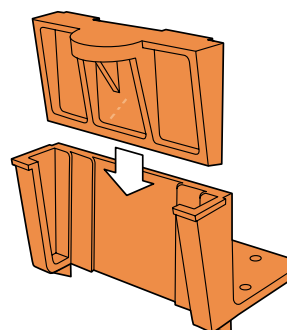

U.S. Patent 6,796,099

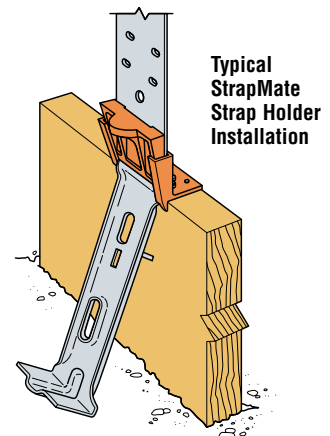

Model No.	Nails	Code Ref.
SM1	2-8d Duplex	180

BP/LBP Bearing Plates

Bearing plates give greater bearing surface than standard cut washers, and help distribute the load at these critical connections.

The BP $\frac{1}{2}$ -3 and BP $\frac{5}{8}$ -3 are available uncoated or with a hot-dip galvanized (HDG) finish.

MATERIAL: See table

FINISH: LBP, LBPS & BP $\frac{5}{8}$ S—Galvanized; BP $\frac{7}{8}$ -2—Zinc Plated; BPS, BP—None. BP's may be ordered HDG; LBP and LBPS products may be ordered ZMAX[®]; check with Simpson Strong-Tie. Refer to page 12–13 for Corrosion Information.

INSTALLATION: See General Notes.

CODES: See page 8 for Code Listing Key Chart.

These products are available with additional corrosion protection. Additional products on this page may also be available with this option, check with Simpson Strong-Tie for details.

Model No.	Thickness	Dimensions		Bolt Dia.	Code Ref.
		W	L		
LBP $\frac{1}{2}$	$\frac{9}{64}$	2	2	$\frac{1}{2}$	180
LBP $\frac{5}{8}$	$\frac{9}{64}$	2	2	$\frac{5}{8}$	
LBPS $\frac{1}{2}$	$\frac{9}{64}$	3	3	$\frac{1}{2}$	180
LBPS $\frac{5}{8}$	$\frac{9}{64}$	3	3	$\frac{5}{8}$	
BPS $\frac{1}{2}$ -3	3 ga	3	3	$\frac{1}{2}$	180
BPS $\frac{5}{8}$ -3	3 ga	3	3	$\frac{5}{8}$	
BP $\frac{1}{2}$	$\frac{3}{16}$	2	2	$\frac{1}{2}$	L8, 180
BP $\frac{1}{2}$ -3	3 ga	3	3	$\frac{1}{2}$	180
BP $\frac{5}{8}$ -2	$\frac{3}{16}$	2	2	$\frac{5}{8}$	
BP $\frac{5}{8}$	$\frac{1}{4}$	2 $\frac{1}{2}$	2 $\frac{1}{2}$	$\frac{5}{8}$	L8
BP $\frac{5}{8}$ -3	3 ga	3	3	$\frac{5}{8}$	180
BP $\frac{3}{4}$	$\frac{5}{16}$	2 $\frac{3}{4}$	2 $\frac{3}{4}$	$\frac{3}{4}$	L8
BP $\frac{3}{4}$ -3	3 ga	3	3	$\frac{3}{4}$	180
BPS $\frac{3}{4}$ -3	3 ga	3	3	$\frac{3}{4}$	
BP $\frac{7}{8}$ -2	$\frac{3}{8}$	1 $\frac{19}{16}$	2 $\frac{1}{4}$	$\frac{7}{8}$	180
BP $\frac{7}{8}$	$\frac{5}{16}$	3	3	$\frac{7}{8}$	L8
BP1	$\frac{3}{8}$	3 $\frac{1}{2}$	3 $\frac{1}{2}$	1	

1. Standard cut washer required with BPS $\frac{1}{2}$ -3 and BPS $\frac{5}{8}$ -3 and BPS $\frac{3}{4}$ -3 (not provided) per the 2006 IRC and IBC.

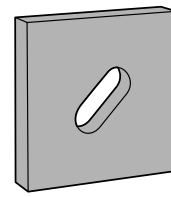

BPS
(LPBS similar)

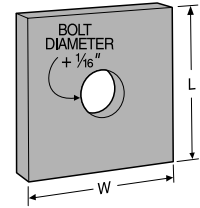

BP
(LBP similar)

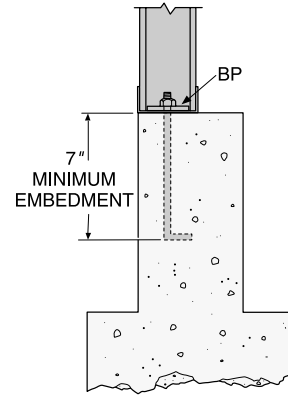

Typical BP Installed with a Bottom Track Anchor Bolt

CNW Coupler Nuts

Simpson Strong-Tie coupler nuts are tested and load rated to join threaded rod and anchor bolts. "Witness" holes in the nut provide a means to verify when rods are properly installed. The holes are aligned to allow inspection of both rods from one viewpoint. The positive stop feature helps ensure even threading into each end of the nut. CNW's meet and exceed the capacity of corresponding ASTM F1554 Grade 36 bolts and threaded rod. HSCNW's meet and exceed the capacity of corresponding ASTM A449 and ASTM A193 Grade B7 bolts and threaded rod. Contact Simpson Strong-Tie for other coupler nut sizes.

FINISH: Zinc Plated

INSTALLATION:

- Tighten the two rods until each all-thread rod is visible in the witness hole.
- For reducer couplers, tighten the coupler into the larger rod first.
- For non-hot dipped galvanized all-thread rod only.
- $\frac{5}{8}$ " and $\frac{7}{8}$ " diameter couplers available with oversized threads for installation to galvanized bolts (order CNW $\frac{5}{8}$ - $\frac{5}{8}$ OST and CNW $\frac{7}{8}$ - $\frac{7}{8}$ OST).

CODES: See page 8 for Code Listing Key Chart.

Model No.	Rod Diameter	H Min	Code Ref.
CNW $\frac{1}{2}$	0.500	1 $\frac{1}{2}$	170
CNW $\frac{5}{8}$	0.625	1 $\frac{7}{8}$	
CNW $\frac{3}{4}$	0.750	2 $\frac{1}{4}$	
CNW $\frac{7}{8}$	0.875	2 $\frac{1}{2}$	
CNW1	1.000	2 $\frac{3}{4}$	
CNW1 $\frac{1}{4}$	1.250	3	
HSCNW $\frac{3}{4}$	0.750	2 $\frac{1}{4}$	
HSCNW1	1.000	2 $\frac{3}{4}$	
Transition Couplers			
CNW $\frac{5}{8}$ - $\frac{1}{2}$	0.625 to 0.500	1 $\frac{1}{2}$	
CNW $\frac{3}{4}$ - $\frac{5}{8}$	0.750 to 0.625	1 $\frac{3}{4}$	
CNW $\frac{7}{8}$ - $\frac{5}{8}$	0.875 to 0.625	2	
CNW1- $\frac{7}{8}$	1.000 to 0.875	2 $\frac{1}{4}$	

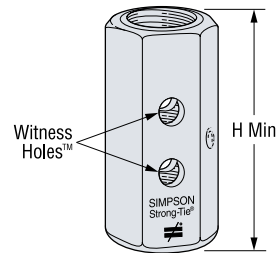

CNW allows fast visual check for correct all thread rod installation

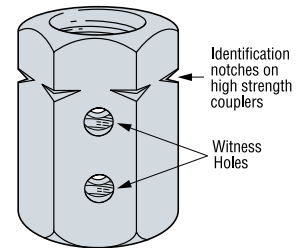

HSCNW High Strength Coupler Nut

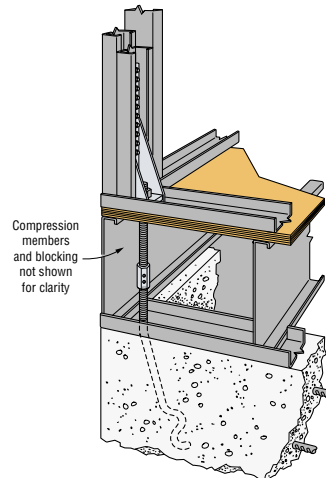

Typical CNW Rim Joist Installation

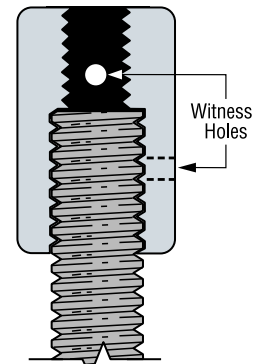

CNW Transition Coupler Nut

MASA/MASAP Mud sill Anchor

Concrete Connectors

The new MASA and MASAP mudsill anchors are easy to install for both the concrete and framing contractor. The anchors are suitable for either stemwall or slab foundations and easily mount on the forms before the pour, simplifying finishing and reducing anchor mislocation problems. The MASA features higher loads and provides an alternative to 5/8" and 1/2" anchor bolts. The MASA eliminates both the need to drill bolt holes in the track and the need for 3" square-plate washers.

The different models of mudsill anchors are designed for specific applications:

- MASA—installed at the top of the form
- MASAP—for panelized forms

MATERIAL: 54 mil. (16 ga.)

FINISH: Galvanized, all available in ZMAX® coating.

See Corrosion Information, page 12-13.

INSTALLATION: • Use all specified fasteners. See General Notes.

• **MASA/MASAP**

- Concrete shall have a minimum $f'_c = 2500$ psi.
- Spalling—Full published capacity is achieved so long as a maximum height of 1 1/4" and a maximum depth of 3/8" is not exceeded. Any exposed portion of the mudsill anchor must be protected against possible corrosion.
- Testing shows that these mudsill anchors can be used in lieu of code-required anchor bolts and square washers in high seismic zones.

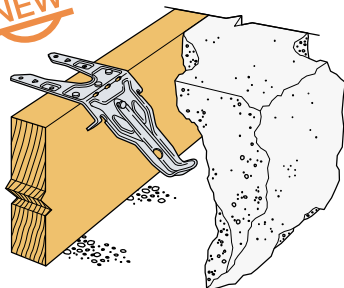
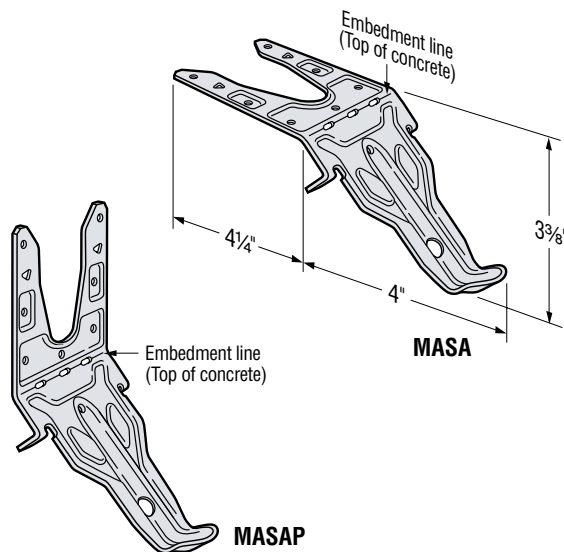

Standard MASA
Installation in Concrete

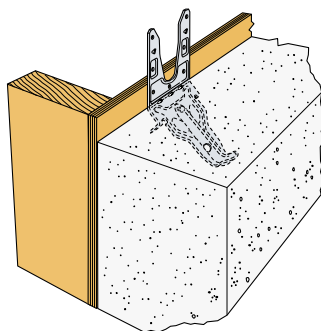

Standard MASAP
Installation in Concrete

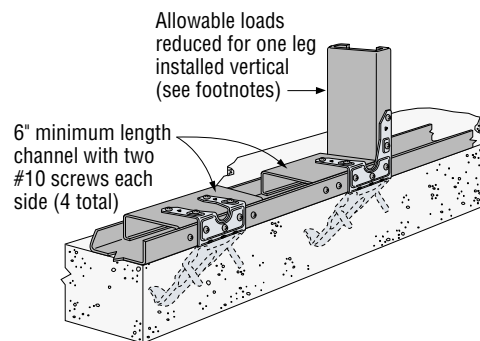

Standard MASA/MASAP
Installation on CFS Track

ALLOWABLE LOADS FOR MASA/MASAP CAST-IN-PLACE MUDSILL ANCHOR ON CFS SILL

Model No.	Fasteners		Allowable Loads (lbs) 43mil (18 ga)						Code Ref.
			STANDARD INSTALLATION						
			Wind & SDC A and B ⁶			SDC C-F			
Sides	Top of Track	Uplift	Parallel-to-Track ⁷	Perp.-to-Track	Uplift	Parallel-to-Track ⁷	Perp.-to-Track		
MASA or MASAP	3- #10	6- #10	Non-Cracked Concrete						170
			740	1325	985	625	1115	825	
			Cracked Concrete						
			560	1325	720	470	1115	605	

For SI: 1 inch = 25.4 mm, 1 pound = 4.45 N, 1 psi = 6.895 kPa

1. Allowable loads are governed by tests and may not be increased ($C_D = 1.0$).
2. To obtain the LRFD loads, the tabulated allowable (ASD) loads shall be multiplied by 1.6 for designs for wind and in SDC A & B, and by 1.43 for designs in SDC C through F.
3. Minimum concrete compression strength, f'_c is 2500 psi.
4. Allowable loads are based on a minimum stemwall width of 6".
5. For simultaneous loads in more than one direction, the connector must be evaluated using the Unity Equation. See page 10, Instructions to the Designer, paragraph b.
6. Per Section 1613 of the 2006 IBC, detached one- and two- family dwellings in SDC C may use the "Wind & SDC A&B" allowable loads.
7. Parallel-to-Track loads for One-Leg-Up Installation: Wind and SDC A-B = 1000 lbs, SDC C-F = 835 lbs.
8. MASA/P loads are based on testing procedures and calculations from ICC-ES Acceptance Criteria, AC398.



LCB Column Base

LCB column bases use screws, which allows for fast installation, reduced reveal and high capacity, while maintaining the net section of the column.

FINISH: LCB - galvanized.

MATERIAL: See table

INSTALLATION: • Use all specified fasteners. See General Notes.

- For full loads, minimum side cover required is 2" for LCB.
- Install all models with bottom of base plate flush with concrete.
- Post bases do not provide adequate resistance to prevent members from rotating about the base and therefore are not recommended for non top-supported installations (such as fences or unbraced carports).

OPTIONS: • The LCB may be shipped unassembled; specify "Disassembled".

CODES: See page 8 for Code Reference Key Chart.

Installation for cold-formed steel built-up column.
Note: The engineer of record is responsible for design of column and beam member.

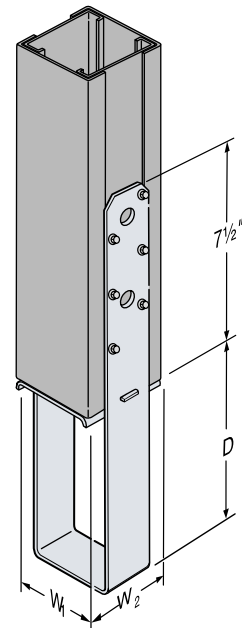

LCB44
(LCB46, LCB66 similar)

Model No.	Column Size	Connector Material Thickness mil (ga)		Dimensions			Column Fasteners Screws	Allowable Uplift Loads		Code Ref.
		Strap	Base	W ₁	W ₂	D		43 mil (18 ga)	54 mil (16 ga)	
LCB44	3.5 x 3.5	97 (12 ga) x 2"	54 (16 ga)	3 3/16	3 1/2	6 1/2	12- #10	3155	5760	FC1
LCB46	3.5 x 3.5	97 (12 ga) x 2"	54 (16 ga)	3 3/16	5 1/2	6 1/2				
LCB66	3.5 x 5.5	97 (12 ga) x 2"	54 (16 ga)	5 1/2	5 1/2	5 1/2				

1. Sizes indicate nominal dimensions.
2. Designer is responsible for concrete design.

LCE Post Cap

The universal design of the LCE4 provides high capacity while eliminating the need for rights and lefts. For use with 3 1/2" to 6" framing members.

MATERIAL: LCE4—33 mil. (20 ga)

FINISH: Galvanized, ZMAX® coating or stainless steel; see Corrosion Information, page 12–13.

INSTALLATION: • Use all specified fasteners. See General Notes.

- Install in pairs.

CODES: See page 8 for Code Reference Key Chart.

These products feature additional corrosion protection. Additional products on this page may also be available with this option, check with Simpson Strong-Tie for details.

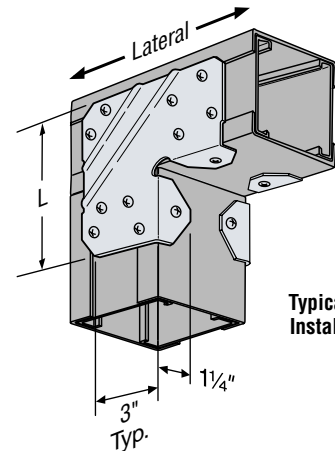

Typical LCE Installation

Installation for cold-formed steel built-up column.
Note: The Designer is responsible for design of column and beam member.

Model No.	Dimensions		Fasteners (Total)		Allowable Loads				Code Ref.
	W	L	Beam	Post	Uplift		Lateral		
					33 mil (20 ga)	43 mil (18 ga)	33 mil (20 ga)	43 mil (18 ga)	
LCE4	—	5 3/8	14- #10	10- #10	1700	2355	1420	2150	170

ANCHOR SYSTEMS – GENERAL INFORMATION



Simpson Strong-Tie Anchor Systems® manufactures a full line of anchoring and fastening products for concrete and masonry. The product line includes adhesives for anchoring and crack injection, mechanical anchors, powder-actuated fasteners, gas-actuated concrete nailer and drill bits. Anchor Systems products offer unique solutions to applications in the light-framed construction market when used with, and without, Simpson Strong-Tie® connectors.

For complete information on product performance, installation requirements and appropriate code listings for Simpson Strong-Tie Anchor Systems® products, please call Simpson Strong-Tie and request an Anchor Systems CD-ROM which contains all of the information you need for your anchoring and fastening needs. In addition to complete product information and the Anchor Designer, Drill Bit Selector and Adhesive Estimator programs, the CD also contains product code reports, MSDS sheets and product fliers.

SET-XP™ Structural Epoxy-Tie Anchoring Adhesive for Cracked and Uncracked Concrete



SET-XP™ Adhesive

SUGGESTED SPECIFICATION:

Anchoring adhesive shall be a two-component high-solids, epoxy-based system supplied in manufacturer's standard cartridge and dispensed through a static-mixing nozzle supplied by the manufacturer. The adhesive anchor shall have been tested and qualified for performance in cracked and uncracked concrete per ICC-ES AC308. Adhesive shall be SET-XP™ Epoxy-Tie® adhesive from Simpson Strong-Tie, Pleasanton, CA. Anchors shall be installed per Simpson Strong-Tie instructions for SET-XP Epoxy-Tie adhesive.

SET-XP™ is a 1:1 two component, high solids epoxy-based anchoring adhesive formulated for optimum performance in both cracked and uncracked concrete. SET-XP™ adhesive has been rigorously tested in accordance with ICC-ES AC308 and 2006 IBC requirements and has proven to offer increased reliability in the most adverse conditions, including performance in cracked concrete under static and seismic loading. SET-XP™ adhesive is teal in color in order to be identified as a high-performance adhesive for adverse conditions. Resin and hardener are dispensed and mixed simultaneously through the mixing nozzle. SET-XP™ adhesive exceeds the ASTM C881 specification for Type I and Type IV, Grade 3, Class C epoxy.

USES: • When SET-XP™ adhesive is used with the IXP™ anchor, all-thread rod or rebar, the system can be used in tension and seismic zones where there is a risk of cracks occurring that pass through the anchor location. It is also suitable for uncracked concrete conditions.



CODES: ICC-ES ESR-2508; City of L.A. RR 25744; Florida FL 11506.5 NSF/ANSI Standard 61 (216 in²/1000 gal). ⚠️ The load tables list values based upon results from the most recent testing and may not reflect those in current code reports. Where code jurisdictions apply, consult the current reports for applicable load values.

APPLICATION: Surfaces to receive epoxy must be clean. The base-material temperature must be 50° F or above at the time of installation. For best results, material should be 70–80° F at the time of application. Cartridges should not be immersed in water to facilitate warming. To warm cold material, the cartridges should be stored in a warm, uniformly-heated area or storage container for a sufficient time to allow epoxy to warm completely. Mixed material in nozzle can harden in 5–7 minutes at a temperature of 40° F or above.

SET-XP Cartridge System

Model No.	Capacity ounces (cubic inches)	Cartridge Type	Carton Quantity	Dispensing tool(s)	Mixing Nozzle
SET-XP22	22 (39.7)	side-by-side	10	EDT22B, EDT22AP, EDT22CKT	EMN22i

1. Cartridge estimation guides are available on page 64 of 2009-2010 Simpson Strong-Tie Anchoring and Fastening Systems for Concrete and Masonry catalog.
2. Detailed information on dispensing tools, mixing nozzles and other adhesive accessories is available on pages 87–92 2009-2010 Simpson Strong-Tie Anchoring and Fastening Systems for Concrete and Masonry catalog.
3. Use only appropriate Simpson Strong-Tie mixing nozzle in accordance with Simpson Strong-Tie instructions. Modification or improper use of mixing nozzle may impair epoxy performance.

Cure Schedule

Base Material Temperature		Cure Time
°F	°C	
50	10	72 hrs.
70	21	24 hrs.
90	32	24 hrs.
110	43	24 hrs.

TITEN HD® Heavy-Duty Screw Anchor for Concrete and Masonry



The Titen HD® anchor is a patented, high-strength screw anchor for concrete and masonry. It is designed for optimum performance in both cracked and uncracked concrete; a requirement that the 2006 IBC places on post-installed anchors. The high-strength, easy-to-install Titen HD anchor has been tested and shown to provide outstanding performance in cracked and uncracked concrete under both static and seismic loading conditions. The self-undercutting, non-expansion characteristics of the Titen HD anchor make it ideal for structural applications, even at reduced edge distances and spacings. Recommended for permanent dry, interior, non-corrosive environments or temporary outdoor applications.

INSTALLATION: Holes in metal fixtures to be mounted should be 1/8" oversized for material thicker than 171 mil (7 ga). Use 1/16" oversized holes for material 171 mil (7 ga) and thinner.

Caution: Oversized holes in the base material will reduce or eliminate the mechanical interlock of the threads with the base material and will reduce the anchor's load capacity. Use a Titen HD screw anchor one time only. Installing the anchor multiple times may result in excessive thread wear and reduced load capacity.

- Drill a hole in the base material using a carbide drill bit the same diameter as the nominal diameter of the anchor to be installed. Drill the hole to the specified embedment depth plus 1/2" minimum to allow the thread tapping dust to settle and blow it clean using compressed

air. Overhead installations need not be blown clean. Alternatively, drill the hole deep enough to accommodate embedment depth and dust from drilling and tapping.

- Insert the anchor through the fixture and into the hole.
- Tighten the anchor into the base material until the hex washer head contacts the fixture.
- If the anchor will not install completely, remove the anchor and assure that all dust has been evacuated or drill the hole deeper. Begin re-installation of the anchor by hand to prevent cross-threading.
- Do not use impact wrenches to install into hollow CMU.

SUGGESTED SPECIFICATIONS: Screw anchors shall have 360-degree contact with the base material and shall not require oversized holes for installation. Fasteners shall be manufactured from carbon steel and are heat-treated. Anchors shall be zinc-plated in accordance with ASTM B633 or mechanically galvanized in accordance with ASTM B695. Anchors are not to be reused after initial installation. Screw anchors shall be Titen HD® anchors from Simpson Strong-Tie, Pleasanton, CA. Anchors shall be installed per the Simpson Strong-Tie instructions for the Titen HD anchor.

*Some jurisdictions require an additional square-plate washer for sill-plate applications.



Titen HD®
screw anchor
U.S. Patent 5,674,035
and 6,623,228

ANCHOR SYSTEMS SET-XP™ Structural Epoxy-Tie Anchoring Adhesive for Cracked and Uncracked Concrete

Simpson Strong-Tie Anchor Systems® products offer several post-installed anchorage solutions for holdowns and bases. Often times these products are used when cast-in-place anchors are omitted or mislocated, or in retrofit applications. The following design values provide solutions to common applications encountered in the light frame construction market.

For complete information on product performance, installation requirements and appropriate code listings for Anchor Systems products please refer to the Anchor Systems catalog (form C-SAS) or visit www.simpsonanchors.com. Also refer to page 10 for Important Instructions to the Designer.

For Corrosion Information, see pages 12–13.

SEISMIC VALUES: IBC Section 1908.1.16 requires that concrete anchors in Seismic Design Categories C through F be governed by the strength of a ductile steel anchor. Anchors noted as limited by the steel capacity satisfy this requirement (footnote 9). Alternately, for anchor solutions limited by the concrete capacity, the IBC requires that either the attachment to the structure shall undergo ductile yielding at a load level less than the anchor design capacity, or the anchor strength shall be at least 2.5 times the demand force.

ANCHORING ADHESIVE SOLUTIONS

Shear Loads for Threaded Rod in Normal-Weight Concrete

Anchor Size	Drill Bit	Edge Distance	End Distance	Emb. Depth	Concrete Thick.	Spacing	Shear Loads ⁶ (lbs/ft)						
							Concrete ⁴				Cold-Formed Steel (ASD) ⁵		
							LRFD ¹ (seismic)	LRFD ¹¹ (wind)	ASD ^{1,2} (seismic)	ASD ^{2,11} (wind)	33 mil (20 ga)	43 mil (18 ga)	54 mil (16 ga)
½	¾	1¼	5	4	6½	0' - 8"	1,360	1,815	970	1,130	895	1,320	2,485
						1' - 0"	905	1,205	645	755	595	880	1,655
						1' - 4"	680	905	485	565	445	660	1,240
						2' - 0"	455	605	325	375	300	440	830
						2' - 8"	340	450	240	285	225	330	620
						4' - 0"	225	300	160	190	150	220	415
						6' - 0"	150	200	110	125	100	145	275
¾	¾	1¼	5	5	8½	0' - 8"	1,525	2,035	1,090	1,270	960	1,490	2,995
						1' - 0"	1,015	1,355	725	845	640	995	2,000
						1' - 4"	760	1,015	545	635	480	745	1,500
						2' - 0"	510	680	365	425	320	495	1,000
						2' - 8"	380	510	270	315	240	375	750
						4' - 0"	255	340	180	210	160	250	500
						6' - 0"	170	225	120	140	105	165	335
¾	¾	1¼	5	6	10	0' - 8"	1,675	2,235	1,195	1,395	965	1,600	3,320
						1' - 0"	1,115	1,485	795	930	640	1,065	2,215
						1' - 4"	835	1,115	595	700	480	800	1,660
						2' - 0"	560	745	400	465	320	535	1,110
						2' - 8"	420	555	300	350	240	400	830
						4' - 0"	280	375	200	230	160	265	555
						6' - 0"	185	245	135	155	105	180	370

Tension Loads for Threaded Rod in Normal-Weight Concrete

Anchor Dia.	Drill Bit	Emb. Depth	Tension Loads ⁶ (lbs)										Tension Loads ¹⁰ Fu = 58 ksi Steel (lbs)	
			Edge and End Distance (C _c)				Minimum Edge (C _{min}) + Critical End (C _c)						LRFD	ASD
			C _c	LRFD ¹ (seismic)	LRFD ¹¹ (wind)	ASD ^{1,2} (seismic)	ASD ^{2,11} (wind)	C _{min}	LRFD ¹ (seismic)	LRFD ¹¹ (wind)	ASD ^{1,2} (seismic)	ASD ^{2,11} (wind)		
½	¾	4	6	3,175	4,235	2,270	2,645	1¼	1,620	2,160	1,155	1,350	6,175	4,265
		7	8	5,525	6,175 ⁹	3,945	3,860	1¼	2,750	3,665	1,965	2,290		
		10	8	6,175 ⁹	6,175 ⁹	4,410	3,860	1¼	3,925	5,235	2,805	3,270		
¾	¾	5	8	3,415	4,555	2,440	2,845	1¼	1,630	2,175	1,165	1,360	9,830	6,675
		8½	8	5,820	7,760	4,155	4,850	1¼	2,735	3,645	1,950	2,280		
		12	9	8,230	9,830 ⁹	5,880	6,145	1¼	3,870	5,160	2,765	3,225		
¾	¾	6	9	6,085	8,115	4,345	5,070	1¼	2,750	3,665	1,965	2,290	14,530	9,615
		10½	12	10,150	13,535	7,250	8,460	1¼	5,050	6,735	3,605	4,210		
		15	15	14,530 ⁹	14,530 ⁹	10,380	9,080	1¼	7,800	10,400	5,575	6,500		
¾	1	8	10	5,305	8,845	3,790	5,530	1¼	2,380	3,965	1,700	2,480	20,095	13,070
		12	12	7,960	13,265	4,975	8,290	1¼	3,570	5,950	2,550	3,720		
		18	14	11,610	19,355	8,295	12,095	1¼	5,205	8,675	3,720	5,420		
1	1½	8	12	9,375	12,500	6,695	7,815	1¼	3,990	5,320	2,850	3,325	26,360	17,075
		14	18	17,890	23,855	12,780	14,910	1¼	7,910	10,545	5,650	6,590		
		20	23	26,360 ⁹	26,360 ⁹	18,830	16,475	1¼	11,645	16,570	8,320	10,355		

- Anchorage designs conform to ACI 318 Appendix D and assume cracked concrete with no supplementary reinforcement.
- Allowable Stress Design (ASD) values are obtained by dividing Load Resistance Factor Design (LRFD) capacities by 1.4 for seismic and 1.6 for wind.
- Load values based on the following: minimum concrete strength of 2,500 psi, dry hole temperature range 1 and continuous special inspection. Reference ICC-ES ESR-2508 for further information.
- Shear load is applied parallel to the edge of concrete. Anchor is considered as an individual anchor without influence from other anchors.
- Cold-Formed Steel (CFS) shear values are based on 2001 AISI NAS, Eq. E3.3.1-1, m_f = 0.75, Ω = 2.5. Reference General Notes for CFS properties. To convert from ASD to LRFD multiply value by 1.5.

- Governing shear load is the lesser of concrete and CFS. Governing tension load is the lesser of concrete and steel.
- For conditions not covered by these tables use the Simpson Anchor Designer ACI 318 Software available at www.simpsonanchors.com.
- Third and fourth edge distances must be ≥ 1.5 x Embedment Depth.
- Failure mode governed by ductile steel rod (A307 Grade C).
- LRFD steel strength based on ACI 318 Appendix D. ASD steel strength based on AISC Steel Construction Manual, 13th Edition, Fu=58 ksi.
- Wind design includes SDC A & B.

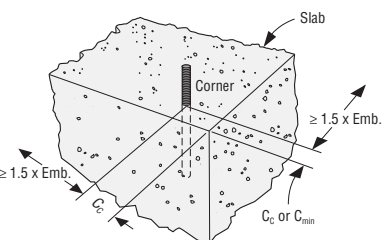

ANCHOR SYSTEMS – TITEN HD® Heavy-Duty Screw Anchor for Cracked and Uncracked Concrete

The Titen HD is a patented, high-strength threaded anchor for concrete and masonry. The self-undercutting, non-expansion characteristics of the Titen HD makes it the ideal anchor for structural applications, even at minimum edge distances and under reduced spacing conditions. The proprietary cutting teeth enable the Titen HD to be installed in significantly less time than traditional expansion anchors, and at significantly reduced installation torques. This heat-treated anchor undercuts the concrete to form a strong mechanical interlock over the entire length of the anchor. The anchor can be installed with a standard ANSI masonry drill bit and is removable. The Titen HD is recommended for permanent dry, non-corrosive applications or temporary outdoor applications.

FEATURES:

- **Higher load capacity and vibration resistance:** Threads along the length of the anchor efficiently transfer the load to the base material.
- **Less spacing and edge distance required:** The anchor does not exert expansion forces on the base material.
- **No special drill bit needed:** Designed to install using standard sized drill bits.
- **Installs with 50% less torque:** Testing shows that when compared with a major competitor, the Titen HD requires 50% less torque to be installed in concrete.
- **Less installation time:** No secondary setting or torquing is required.
- **Stamped Hex-washer head:** Requires no separate washer and provides a clean installed appearance. The head is stamped with the Simpson Strong-Tie sign and the anchor length in inches for easy inspection. (Some local building jurisdictions may require a separate washer.)
- **Removable:** Ideal for temporary anchoring (e.g. formwork, bracing) or applications where fixtures may need to be moved.

• Mechanical galvanized coating is available. Refer to www.strongtie.com/info for corrosion information.

CODES: ICC ESR-2713; ICC ESR-1056; City of L.A. RR25560; City of L.A. RR25741; Florida FL 11506.7.
SEISMIC VALUES: IBC Section 1908.1.16 requires that concrete anchors in Seismic Design Categories C through F be governed by the strength of a ductile steel anchor. Alternately, for anchor solutions limited by the concrete capacity, the IBC requires that either the attachment to the structure shall undergo ductile yielding at a load level less than the anchor design capacity, or the anchor strength shall be at least 2.5 times the demand force.

For complete technical information please refer to the Simpson Strong-Tie® Anchoring and Fastening Systems for Concrete and Masonry catalog.

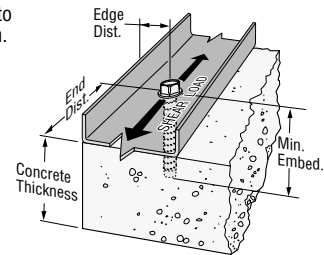

Edge and end distances for Titen HD in concrete slab corner condition
U.S. Patent 5,674,035

Titen HD® – Shear and Tension Loads Attaching Cold-Formed Steel To Normal-Weight Concrete

Anchor Size	Drill Bit	Edge Distance	End Distance	Min. Emb. Depth	Concrete Thick.	Spacing	Concrete ^{2,4} (seismic)				Cold-Formed Steel (ASD) ⁵			
							LRFD ¹ (seismic)	LRFD ⁸ (wind)	ASD ^{1,2} (seismic)	ASD ^{2,8} (wind)	33 mil (20 ga)	43 mil (18 ga)	54 mil (16 ga)	68 mil (14 ga)
Shear Loads Parallel-to-Edge⁶ (lbs/ft)														
3/8 x 3	3/8	1 1/4	7	2 1/2	3 3/4	0' - 8"	660	880	475	550	765	1,030	1,860	2,350
						1' - 0"	440	585	315	365	510	685	1,240	1,565
						1' - 4"	330	440	235	275	385	515	930	1,175
						2' - 0"	220	295	155	185	255	340	620	780
						2' - 8"	165	220	120	135	190	255	465	585
						4' - 0"	110	145	80	90	130	170	310	390
1/2 x 4	1/2	1 1/4	8	3 3/4	5	0' - 8"	1,065	1,420	760	890	895	1,320	2,485	3,130
						1' - 0"	710	945	505	590	595	880	1,655	2,085
						1' - 4"	535	710	380	445	445	660	1,240	1,565
						2' - 0"	355	475	255	295	300	440	830	1,045
						2' - 8"	265	355	190	220	220	330	620	780
						4' - 0"	180	240	130	150	150	220	415	520
Tension Loads⁶ (lbs)														
3/8 x 3	3/8	1 1/4	3	2 1/2	3 3/4	6	600	800	430	500	390	505	920	1,160
1/2 x 4	1/2	1 1/4	4	3 1/4	5	8	940	1,255	670	785	390	505	920	1,160
		4	4	3 3/4	5	8	1,490	1,985	1,065	1,240				

1. Seismic tabulated values are for cracked concrete; an adjustment factor of 0.75 is assumed per ACI 318 Section D.3.3.3 for SDC C through F. See note regarding SEISMIC VALUES.
2. Converting LRFD to ASD assume LRFD values divided by 1.4 and 1.6 for seismic and wind respectively.
3. Shear load is applied parallel to the edge of concrete. Anchor is considered as an individual anchor without influence from other anchors
4. Concrete shall have a minimum f'c of 2,500 psi. Reference ICC-ES ESR-2713 for further information.

5. CFS values are based on 2001 AISI NAS, Eq. E3.3.1-1 for shear (m_f = 0.75, Ω = 2.5) and Eq. E4.4.2-1 for tension (Ω = 3.0, d_w = 0.5"). Reference General Notes for CFS properties.
6. Governing load is the lesser of Concrete and CFS.
7. For conditions not covered by this table use the Simpson Anchor Designer ACI 318 Software available at www.simpsonanchors.com.
8. Wind tabulated values are for uncracked concrete without supplemental reinforcement. Wind design includes SDC A and B.

TITEN® Concrete & Masonry Screws

Titen screws are 3/16" and 1/4" diameter masonry screws for attaching all types of components to masonry. Carbon-steel Titen screws are available in hex and phillips head designs in blue, white or silver colors. Use with appropriately sized Titen drill bits included with each box.

CODES: FL 2355.1 (Carbon-steel Titen)

Titen Installation Sequence

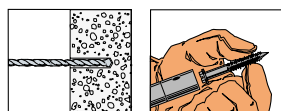

WARNING: Carbon Steel: Industry studies show that hardened fasteners can experience performance problems in wet environments. Accordingly, use this product in dry, interior applications only. Stainless Steel: Acceptable for use in exterior environments. See corrosion on page 16 of C-SAS-2009.



Special hex adapter on the bit allows the Titen Installation Tool to slide over the bit and lock in, ready to drive screws.



Titen® Screws – Shear and Tension Loads

Anchor Size	Embed Depth	Edge Distance	Spacing	CMU ¹		Cold-Formed Steel ²	
				Screw Steel Type	Carbon	Stainless	33 mil (20 ga)
(ASD) Allowable Shear Load^{3,4} (lbs/ft)							
3/16	1	1 1/8	0'-4"	615	—	795	1020
			0'-6"	410	—	530	680
			1'-0"	205	—	265	340
			1'-6"	135	—	175	225
			2'-0"	100	—	135	170
			3'-0"	70	—	90	115
1/4	1	1 1/2	0'-4"	750	300	1050	1365
			0'-6"	500	200	700	910
			1'-0"	250	100	350	455
			1'-6"	165	65	235	305
			2'-0"	125	50	175	230
			3'-0"	85	35	115	150
(ASD) Allowable Tension Load^{3,4} (lbs)							
3/16	1	1 1/8	2 1/4	110	—	240	315
1/4	1	1 1/2	4	150	110	290	380

1. Allowable loads are based on a safety factor of 5.0 for installations under the IBC and IRC.
2. Cold-Formed Steel (CFS) values are based on 2001 AISI NAS, Section E4, Ω=3.0, d_w=5/16" (3/16" Titen) and d_w=3/8" (1/4" Titen). Reference General Notes for CFS properties.
3. Governing load is the lesser of CMU and CFS.
4. Use interaction formula for combined tension and shear (P_s/P_t) + (V_s/V_t) ≤ 1.0.

GCN150 Gas-Actuated Concrete Nailer

The GCN150 gas-actuated concrete nailer is a portable fastening tool for attaching light-duty fixtures such as drywall track, furring strips, hat track and angle track to concrete, steel, CMU and metal deck. The GCN150 has a portable gas fuel supply that does not require electrical cords or hoses. The GCN150 sets up quickly and offers maximum productivity. With a 500 shot-per-hour capacity and a pin jam release door, the GCN150 makes fastening pins fast and easy. Additional attributes include 2-step pin loading into the magazine, light and well-balanced weight, a battery indicator light and a sure-grip rubber handle pad.

The GDP concrete pins are designed to work with the GCN150 Gas-Actuated Concrete Nailer as well as with most major brand gas concrete nailer tools. The patent-pending plastic collation of the 10-pin strip is a break-away design that minimizes the possibility of a jam. The GDP pins are designed for use in A36 and A572 steel, concrete and CMU block.

GDP pins are code listed under ICC-ES ESR-2811. This report covers the fastening of building components, such as cold-formed-steel framing members, to normal-weight concrete, structural sand-lightweight concrete, structural sand-lightweight concrete on metal deck, concrete masonry units (CMU) and steel base materials. GDP gas-actuated pins were tested in accordance with ICC-ES Acceptance Criteria AC70 for recognition under the 2006 IBC, the 2006 IRC and the 1997 UBC.

CODES: ICC-ES ESR-2811



GDP
(Patent Pending)



Anchors

0.106 Diameter Shank Drive Pins for the GCN150

Model No.	Length	Qty Pins / pack +1 Fuel Cell	Packs/ Carton	Compatible with these Tools
GDP-50KT	½"	1,000	5	Simpson Strong-Tie GCN150 Others: TF1100, C3
GDP-62KT	⅝"	1,000	5	
GDP-75KT	¾"	1,000	5	
GDP-100KT	1"	1,000	5	
GDP-125KT	1¼"	1,000	5	
GDP-150KT	1½"	1,000	5	

GDP Pin – Shear and Tension Loads

Model Type	Dia.	Spacing	Base Material					Attached Material		
			Normal-Weight Concrete ¹		A36 Steel ²			Cold-Formed Steel ³		
			2,000 psi	4,000 psi	¼"	⅜"	½"	33 mil (20 ga)	43 mil (18 ga)	54 mil (16 ga)
GDP	0.106	Allowable Shear Load⁴ (lbs/ft)								
		0'-4"	135	225	435	675	855	445	580	1055
		0'-6"	90	150	290	450	570	295	385	700
		0'-8"	70	115	215	340	430	225	290	525
		1'-0"	45	75	145	225	285	150	195	350
		2'-0"	25	40	75	115	145	75	95	175
	3'-0"	15	25	50	75	95	50	65	115	
0.106	—	Allowable Tension Load⁴ (lbs)								
			30	30	185	210	125	195	255	460

1. For Normal-Weight Concrete the minimum edge distance and spacing is 3" and 4" respectively with ¼" minimum embedment.
2. For A36 Steel the minimum edge distance and spacing is 0.5" and 1" respectively. Fastener must fully penetrate steel base material.
3. Cold-Formed Steel (CFS) values are based on 2001 AISI NAS, Section E4. Reference General Notes for CFS properties.
4. Governing load is the lesser of the base material and CFS.

POWDER-ACTUATED FASTENERS

Powder-actuated fasteners provide a quick and economical method for fastening cold-formed steel to concrete or steel base materials.

CODES: ICC-ES ESR-2138; City of LA RR 25469; FL 11506.3

In Normal-Weight Concrete

PDP-Series Fasteners

PDP*	PDPW	PDPWL*
PDP-125	PDPW-125	PDPWL-125
PDP-150	PDPW-150	PDPWL-150
PDP-175	PDPW-175	PDPWL-175
PDP-200	PDPW-200	PDPWL-200
PDP-225	—	—
PDP-250	PDPW-250	PDPWL-250
PDP-300	PDPW-300	PDPWL-300
1. *Including stainless steel models.		PDPWL-400

PHN-Series Fasteners

PHN	PHNW	PHSNA
PHN-27	PHNW-27	PHSNA-27
PHN-32	PHNW-32	PHSNA-32
PHN-37	PHNW-37	PHSNA-37
PHN-42	PHNW-42	PHSNA-42
PHN-47	PHNW-47	PHSNA-47
PHN-52	PHNW-52	PHSNA-52
PHN-57	PHNW-57	PHSNA-57
PHN-62	PHNW-62	PHSNA-62
PHN-72	PHNW-72	PHSNA-72

In Lightweight Concrete Over Steel Deck

PDPT-Series Fasteners

PDPT	
PDPT-50K	(knurled)
PDPT-62K	(knurled)
PDPT-75	
PDPT-100	

In Steel

PDP-Series Fasteners

PDP	PDPW	PDPWL
PDP-100	PDPW-100	PDPWL-100
PDP-125	PDPW-125	PDPWL-125
PDP-150	PDPW-150	PDPWL-150
PDP-175	PDPW-175	PDPWL-175
PDP-200	PDPW-200	PDPWL-200
PDP-225	—	—
PDP-250	PDPW-250	PDPWL-250
PDP-300	PDPW-300	PDPWL-300

PHN-Series Fasteners

PHN	PHNW	PHSNA
PHN-27	PHNW-27	PHSNA-27
PHN-32	PHNW-32	PHSNA-32
PHN-37	PHNW-37	PHSNA-37
PHN-42	PHNW-42	PHSNA-42
PHN-47	PHNW-47	PHSNA-47
PHN-52	PHNW-52	PHSNA-52
PHN-57	PHNW-57	PHSNA-57
PHN-62	PHNW-62	PHSNA-62
PHN-72	PHNW-72	PHSNA-72

Typical Powder-Actuated Fastener Installation

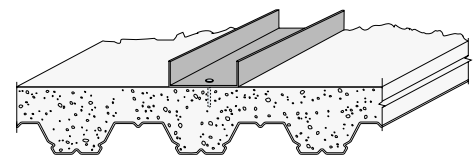
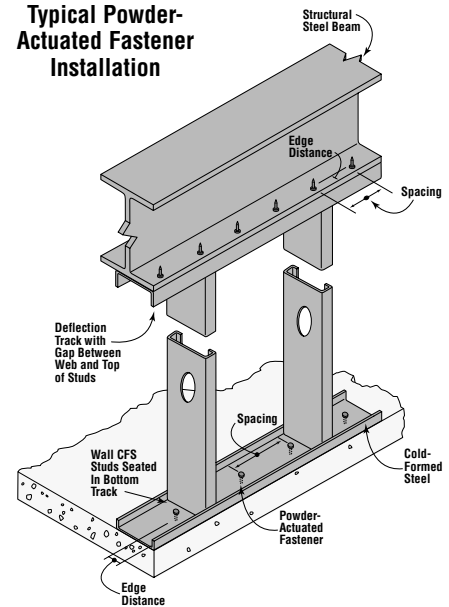

PRODUCT NOMENCLATURE

EXAMPLE:

PDP-175 = 0.145 Dia. PIN x 1¾" length (no washer)

PHN-52 = 0.145 Dia. PIN x 52mm length (no washer)

PDPT-100 = 0.145 Dia. PIN x 1" length (no washer)

W = ¾" Dia. metal washer (PDP)
1" Dia. metal washer (PHN)

WL = 1" Dia. metal washer (PDP)

Refer to the latest Simpson Strong-Tie® Anchor and Fastening Systems for Concrete and Masonry catalog for further information on powder-actuated fasteners

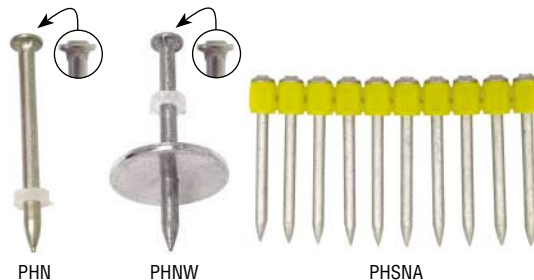

POWDER-ACTUATED FASTENERS

PDP/PHN Pin – Shear and Tension Loads

Model Type	Dia.	Spacing	Base Material			Attached Material								
			Normal Weight Concrete ¹		A36 Steel ²	Cold Formed Steel ³								
			Emb. Depth	2,000 psi	4,000 psi	3/16"	33 mil (20 ga)	43 mil (18 ga)	54 mil (16 ga)					
PDP PHN	0.145	0'-4"	1	360	615	1185	610	795	1440					
			1¼	795	795									
			0'-6"	1	240					410	790	405	530	960
				1¼	530					530				
			0'-8"	1	180					310	595	305	395	720
				1¼	400					400				
		1'-0"	1	120	205	395	205	265	480					
			1¼	265	265									
		2'-0"	1	60	105	200	100	130	240					
			1¼	135	135									
		3'-0"	1	40	70	130	70	90	160					
			1¼	90	90									
	Allowable Tension Load⁴ (lbs)													
	0.145	—	1	45	150	155	235	305	550					
1¼			140	370										

1. For Normal-Weight Concrete the minimum edge distance and spacing is 3" and 4" respectively.
2. For A36 Steel the minimum edge distance and spacing is 0.5" and 1" respectively. Fastener must fully penetrate steel base material.
3. Cold-Formed Steel (CFS) values are based on 2001 AISI NAS, Section E4. Reference General Notes for CFS properties.
4. Governing load is the lesser of the base material and CFS.
5. Allowable loads for Base Material are based on ESR-2138.

PDPT Pin – Shear and Tension Loads

Model Type	Dia.	Spacing	Base Material				Attached Material		
			Light Weight Concrete ^{1, 2}		A36 Steel ⁴		Cold Formed Steel ⁵		
			Concrete (Top)	Lower Flute ³ (Bottom)	¼"	⅜"	33 mil (20 ga)	43 mil (18 ga)	54 mil (16 ga)
PDPT	0.145	0'-4"	750	825	2100	1980	610	795	1440
			500	550	1400	1320	405	530	960
			375	415	1050	990	305	395	720
			250	275	700	660	205	265	480
			125	135	350	330	100	130	240
			85	90	235	220	70	90	160
	Allowable Tension Load⁶ (lbs)								
	0.145	—	85	40	340	290	235	305	550

1. For Light-Weight Concrete the minimum edge distance and spacing is 3" and 4" respectively with ⅝" minimum embedment. Concrete shall have a minimum compressive strength of f_c=3000 psi.
2. For steel deck the minimum depth and thickness is 3" and 33mil (20ga) respectively.
3. For deck web the minimum edge and end distance is 1½" and 4" respectively with 4" minimum spacing.
4. For A36 Steel the minimum edge distance and spacing is 0.5" and 1" respectively. Fastener must fully penetrate steel base material.
5. Cold-Formed Steel (CFS) values are based on 2001 AISI NAS, Section E4. Reference General Notes for CFS properties.
6. Governing load is the lesser of the base material and CFS.
7. Allowable loads for Base Material are based on ESR-2138.

SB Anchor Bolt

The geometry of the SB bolt is the latest development in high-capacity anchors. The smooth transition angle of the bolt positions the head of the anchor into an optimum position in the concrete stem wall without creating excessive horizontal forces. The SB $\frac{7}{8}$ x24 is designed to maximize performance with minimum embedment while the SB1x30 is intended to cover holddown devices which exceed the capacity of SSTB anchor bolts.

Special Features:

- Identification on the bolt head showing embedment angle and model
- Stamped embedment line
- Rolled thread for higher tensile capacity
- Tested in different compressive strength concretes for versatility in specification

MATERIAL: ASTM F1554 Grade 36

FINISH: None. May be ordered hot-dip galvanized (HDG). Contact Simpson Strong-Tie.

INSTALLATION:

- SB is only for concrete applications poured monolithically unless otherwise noted.
- Install 1-#4 rebar in the area 3" to 5" (*may be foundation rebar not post-tension cable*) from the top of the foundation.
- Top nuts and washers for holddown attachment are not supplied with the SB; install standard nuts, couplers and/or washers as required.

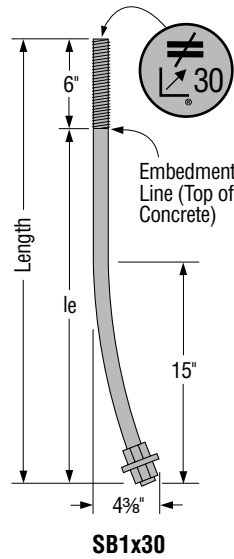

U.S. Patent
5,317,850

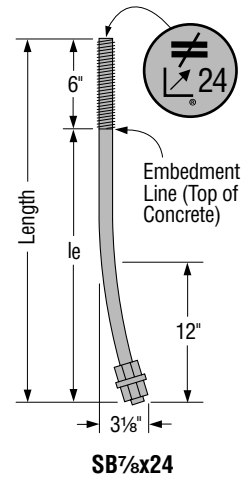

Recent testing by Simpson Strong-Tie to the new ICC-ES Acceptance Criteria for *Cast-In-Place Proprietary Bolts* in concrete for Light-Frame Construction (AC399) has been submitted to ICC-ES for code approval. Reference www.strongtie.com for published load information and new ICC-ES code report with evaluation scope in compliance with the 2006 and 2009 IBC and 2006 and 2009 IRC.

SSTB Anchor Bolts

The SSTB is designed for maximum performance as an anchor bolt for holdowns and Strong-Wall® shearwalls. Extensive SSTB testing has been done to determine the design load capacity at a common application, the garage stem wall. Design loads are based on recent testing by Simpson Strong-Tie to the new ICC-ES acceptance criteria for cast-in-place proprietary bolts in concrete for light-frame construction (AC 399).

SPECIAL FEATURES:

- Rolled threads for higher tensile capacity.
- Offset angle reduces side-bursting, provides more concrete cover.
- Stamped embedment line aids installation.
- Configuration results in minimum rebar interference.

MATERIAL: ASTM F1554 Grade 36

FINISH: None. May be ordered hot-dip galvanized (HDG); check with Simpson Strong-Tie

INSTALLATION:

- SSTB is used for monolithic and two-pour installations.
- Nuts and washers are not supplied with the SSTB; install standard nuts, couplers and/or washers as required. On HDG SSTB anchors, chase the threads to use standard nuts or couplers or use overtapped products in accordance with ASTM A563 (*Simpson Strong-Tie NUT^{5/8}-OST, NUT^{7/8}-OST, CNW^{5/8}-5/8OST, CNW^{7/8}-7/8OST*).

REINFORCED CONCRETE FOUNDATION

- Install SSTB before the concrete pour using AnchorMates (*see page 16*). Install the SSTB per plan view detail shown on page 28. Install one #4 rebar 3" to 5" (*may be foundation rebar not post-tension cable*) from the top of the foundation.
- The SSTB does not need to be tied to the rebar.
- Minimum concrete compression strength is 2500 psi. Unless noted otherwise, no special inspection is required for foundation concrete when the structural design is based on concrete no greater than 2500 psi (*IBC Section 1704.4*).
- Unless otherwise noted, do NOT install where: (a) a horizontal cold joint exists within the embedment depth between the slab and foundation wall or footing beneath, unless provisions are made to transfer the load, or the slab is designed to resist the load imposed by the anchor; or (b) slabs are poured over concrete block foundation walls.

REINFORCED CONCRETE BLOCK

- Before concrete grout is poured, install diagonally at approx. 45° in the cell per plan view detail shown on next page.
- Horizontal #4 rebar (*minimum 56" long centered about the anchor bolt*)—approximately one rebar 12" from the top and two rebars approximately 28" from the top. Vertical #4 rebar (*minimum 24" long*)—install with maximum 24" o.c. spacing.
- Grout all cells with minimum 2000 psi concrete. Vibrate the grout per the International Building Code, Section 2104.1.
- Refer to Simpson Strong-Tie® *Wood Construction Connectors* catalog for allowable tension loads in masonry.

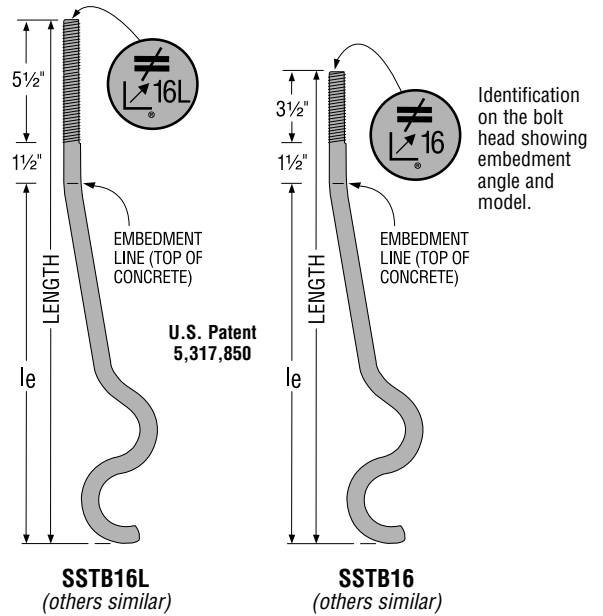

Recent testing by Simpson Strong-Tie to the new ICC-ES Acceptance Criteria for *Cast-In-Place Proprietary Bolts* in concrete for Light-Frame Construction (AC399) has been submitted to ICC-ES for code approval. Reference www.strongtie.com for published load information and new ICC-ES code report with evaluation scope in compliance with the 2006 and 2009 IBC and 2006 and 2009 IRC.

SSTB Anchor Bolts

Anchors

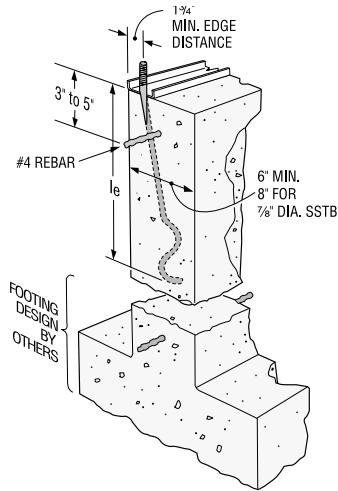

Typical SSTB Installation
Maintain minimum rebar cover, per ACI-318 concrete code requirements

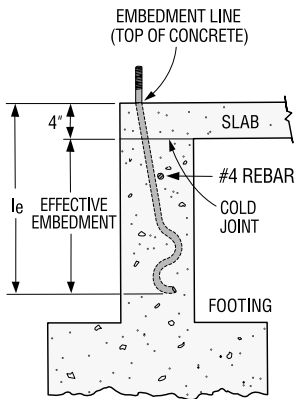

Two-Pour Installation
(SSTB20, 24 and 34)

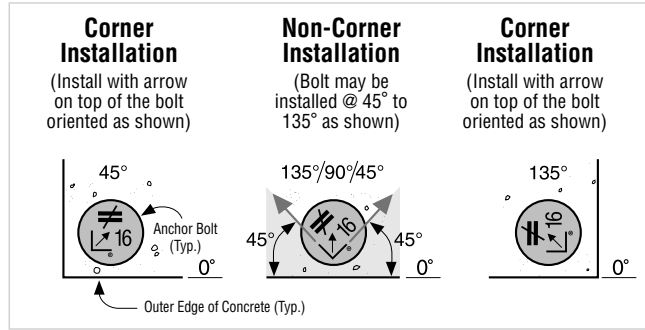

Plan View of SSTB Placement in Concrete Stemwall

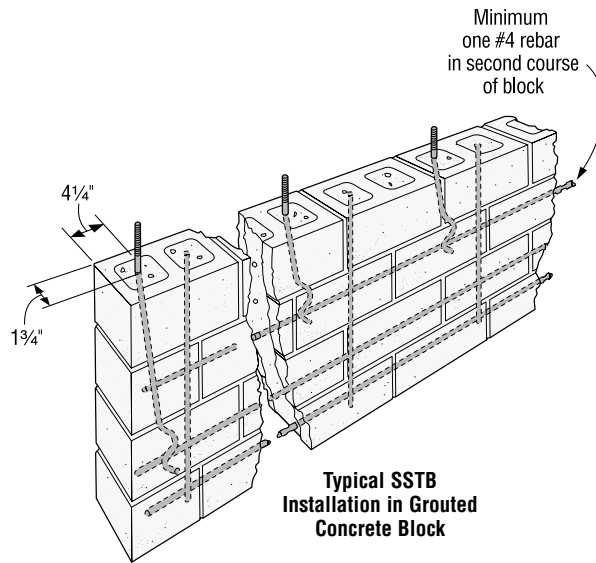

Typical SSTB Installation in Grouted Concrete Block

RFB Retrofit Bolts

RFBs are clean, pre-cut threaded rod, supplied with nut and washer for use with Simpson Strong-Tie® anchoring adhesives. May be ordered in bulk without the nut and washer. Use with Simpson Strong-Tie anchoring adhesives to anchor into existing concrete and masonry. Offers a complete engineered anchoring system when used with Simpson Strong-Tie anchoring adhesives. Inspection is easy; each end of the threaded rod is stamped with rod length in inches and “No-Equal” symbol for identification after installation.

MATERIAL: A307, Grade C

FINISH: Zinc-Plated, Hot-Dip Galvanized (per ASTM 153). Stainless Steel (RFB#5/8x8SS)

INSTALLATION:

- Request the current *Anchoring and Fastening Systems for Concrete and Masonry* catalog for more information.

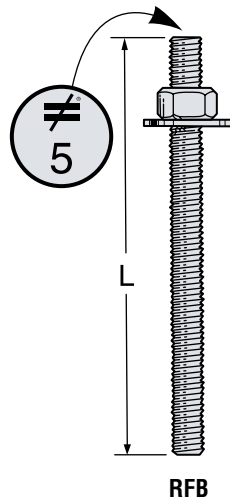

These products feature additional corrosion protection. Additional products on this page may also be available with this option, check with Simpson Strong-Tie for details.

Description Dia. Length	Zinc Plated Model No.	Hot-Dip Galvanized Model No.	Ctn Qty	Bulk ¹ Qty	Retail ² Pack
1/2" x 4"	RFB#4x4	RFB#4x4HDG	50	50	—
1/2" x 5"	RFB#4x5	RFB#4x5HDG	50	50	10
1/2" x 6"	RFB#4x6	RFB#4x6HDG	50	50	10
1/2" x 7"	RFB#4x7	RFB#4x7HDG	50	50	10
1/2" x 8"	—	RFB#4x8HDG	—	—	10
1/2" x 10"	RFB#4x10	RFB#4x10HDG	25	—	10
5/8" x 5"	RFB#5x5	RFB#5x5HDG	50	50	10
5/8" x 8"	RFB#5x8	RFB#5x8HDG	50	—	10
5/8" x 10"	RFB#5x10	RFB#5x10HDG	50	—	10
5/8" x 12"	—	RFB#5x12HDG	—	—	10
5/8" x 16"	RFB#5x16	RFB#5x16HDG	25	25	10
3/4" x 10 1/2"	RFB#6x10.5	RFB#6x10.5HDG	25	25	—

- Bulk quantities do not include the nut and washer and must be ordered with a “-B” suffix (example: RFB#4x5-B). Hot-dip galvanized RFB’s not available in bulk.
- Retail Packs must be ordered with a “-R” suffix (example: RFB#5x12HDG-R).

PAB Pre-Assembled Anchor Bolt

The PAB anchor bolt is a versatile new cast-in-place anchor bolt ideal for high-tension-load applications. It features a plate washer at the embedded end sandwiched between two fixed hex nuts and a head stamp for easy identification after the pour.

- Available in diameters from 1/2" to 1 1/4" in lengths from 6" to 36" (in 1/2" increments)
- Available in standard and high-strength steel
- Head stamp contains the No Equal sign, diameter designation and an "HS" on high-strength rods

MATERIAL: Standard Steel – $F_u = 58$ ksi
High-Strength Steel (up to 1" dia.) – $F_u = 120$ ksi
High-Strength Steel (1 1/8" and 1 1/4" dia.) – $F_u = 125$ ksi

FINISH: None

The Simpson Strong-Tie® Anchor Designer Software™ for ACI 318 analyzes and suggests anchor solutions using the ACI 318 Appendix D strength-design methodology (or CAN/CSA A23.3 Annex D Limit States Design methodology). It provides cracked and uncracked-concrete anchorage solutions for numerous



Simpson Strong-Tie Anchor Systems® mechanical and adhesive anchors as well as the PAB anchor bolt. With its easy-to-use graphical user interface, the software makes it easy for the Designer to identify anchorage solutions without having to perform time-consuming calculations by hand.

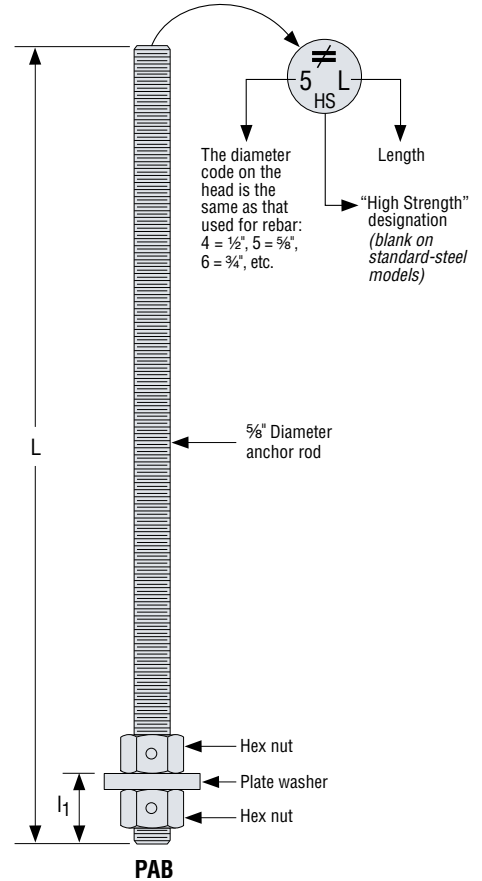

Anchors

PAB Anchor Bolt – Standard Steel

Diameter (in.)	Plate Washer Size (in.)	l ₁ (in.)	Root Model No.	Length Range
1/2	1/4 x 1 1/4 x 1 1/4	1	PAB4-XX	6" to 36" (in 1/2" increments)
5/8	3/8 x 1 1/2 x 1 1/2	1 1/4	PAB5-XX	
3/4	3/8 x 2 x 2	1 3/8	PAB6-XX	
7/8	3/8 x 2 1/4 x 2 1/4	1 1/2	PAB7-XX	
1	3/8 x 2 1/2 x 2 1/2	1 5/8	PAB8-XX	
1 1/8	3/8 x 2 3/4 x 2 3/4	1 3/4	PAB9-XX	
1 1/4	1/2 x 3 x 3	2 1/2	PAB10-XX	

How to specify and order:

When calling out PAB anchor bolts, substitute the desired length for the "XX" in the Root Model Number.

So for a 5/8" x 16 1/2" anchor bolt, the model number would be PAB5-16.5 (or PAB5H-16.5 for high strength).

PAB Anchor Bolt – High-Strength Steel

Diameter (in.)	Plate Washer Size (in.)	l ₁ (in.)	Root Model No.	Length Range
1/2	1/4 x 1 1/4 x 1 1/4	1	PAB4H-XX	6" to 36" (in 1/2" increments)
5/8	3/8 x 1 1/2 x 1 1/2	1 1/4	PAB5H-XX	
3/4	3/8 x 2 x 2	1 3/8	PAB6H-XX	
7/8	3/8 x 2 1/4 x 2 1/4	1 1/2	PAB7H-XX	
1	3/8 x 2 1/2 x 2 1/2	1 5/8	PAB8H-XX	
1 1/8	3/8 x 2 3/4 x 2 3/4	1 3/4	PAB9H-XX	
1 1/4	1/2 x 3 x 3	2 1/2	PAB10H-XX	

Naming Scheme:



* Units in 1/8" Increments (Ex: 9 = 3/8" or 1 1/8")

1. Plate washers are designed to develop the capacity of the bolt.

PAB Pre-Assembled Anchor Bolt

In addition to anchorage solutions provided by the SB and SSTB anchor bolts, the following table provides design options using the new PAB anchor bolts. These solutions may be used with Simpson Strong-Tie holdowns and are calculated per ACI 318 Appendix D. For special loads or footing geometries not addressed in the table below, the new PAB anchor bolts are also included in Simpson Strong-Tie Anchor Systems Anchor Designer ACI 318 software, which is available for download at www.simpsonanchors.com.

PAB ANCHOR BOLT ANCHORAGE SOLUTIONS

Design Criteria	Diameter	Anchor Bolt Model No.	2500 psi Concrete				3000 psi Concrete			
			d_e	F	ASD	LRFD	d_e	F	ASD	LRFD
Wind	5/8	PAB5	4	6	4,200	6,720	4	6	4,600	7,360
			5	7½	5,870	9,390	5	7½	6,140	9,830
	¾	PAB6	5	7½	5,870	9,390	5	7½	6,430	10,290
			6	9	7,720	12,350	5	7½	6,430	10,290
	7/8	PAB7	8	12	11,880	19,010	7	10½	10,650	17,040
			10	15	16,600	26,560	10	15	18,190	29,100
			14	28	25,970	41,560	13	26	25,970	41,560
	1	PAB8	8	12	11,880	19,010	7	10½	10,650	17,040
			10	15	16,470	26,350	9	13½	15,530	24,840
		PAB8H	11	16½	19,040	30,470	11	16½	20,860	33,380
			16	24	34,070	54,520	15	22½	34,070	54,520
	1½	PAB9	6	9	7,720	12,350	6	9	8,450	13,520
			9	13½	14,180	22,680	9	13½	15,530	24,840
			11	16½	19,040	30,470	10	15	18,190	29,100
1¼	PAB10	12	24	22,010	35,220	11	16½	20,860	33,380	
Seismic	5/8	PAB5	7	10½	6,870	9,830	6	9	6,870	9,830
	¾	PAB6	9	13½	10,170	14,550	8	12	10,170	14,550
	7/8	PAB7	11	16½	14,050	20,090	10	15	14,050	20,090
		PAB7H	16	24	29,060	41,560	15	22½	29,060	41,560
	1	PAB8	12	18	18,430	26,350	12	18	18,430	26,350
		PAB8H	19	28½	38,120	54,520	18	27	38,120	54,520
	1½	PAB9	14	21	23,220	33,200	13	19½	23,220	33,200
	1¼	PAB10	16	24	29,480	42,160	16	24	29,480	42,160

1. Anchorage designs conform to ACI 318 Appendix D and assume cracked concrete with no supplementary reinforcement.
2. Seismic indicates Seismic Design Category C through F. Detached 1 and 2 family dwellings in SDC C may use wind anchorage solutions. Seismic anchorage designs conform to ACI 318-05 Section D3.3.4
3. Wind includes Seismic Design Category A and B.
4. Foundation dimensions are for anchorage only. Foundation design (size and reinforcement) by Designer. The registered design professional may specify alternate embedment, footing size, and anchor bolt.
5. Allowable Stress Design (ASD) values are obtained by dividing Load Resistance Factor Design (LRFD) capacities by 1.43 for Seismic and 1.6 for Wind.

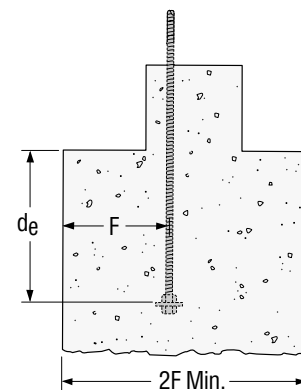

Anchor with Nut/Washer/Nut

Design loads are calculated using a full shear cone. Coverage on each side of the bolt shall be a minimum of Dimension F (above) or reductions must be taken.

S/HDU Holdowns

The S/HDU series of holdowns combines performance with ease of installation. The pre-deflected geometry virtually eliminates material stretch, resulting in low deflection under load. Installation using self-drilling tapping screws into the studs reduces installation time and saves labor cost.

MATERIAL: 118 mil (10 ga)

FINISH: Galvanized

INSTALLATION: • Use all specified fasteners.
See General Notes.

• Use #14 screws to fasten to studs

CODES: See page 8 for Code Listing Key Chart.

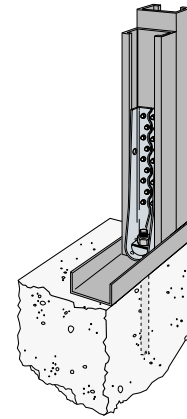
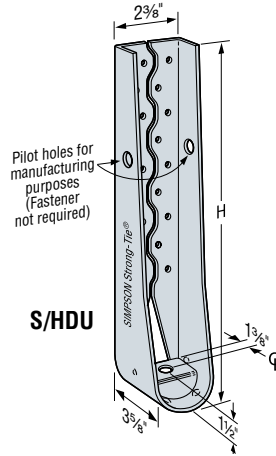

Typical S/HDU Installation

Holdowns & Tension Ties

These products are available with additional corrosion protection. Additional products on this page may also be available with this option, check with Simpson Strong-Tie for details.

Model	H	Fasteners		Stud Member Thickness ⁴	ASD		LRFD		Nominal Tension Load ⁸	Code Ref.
		Fdn Anchor Dia ¹	Stud Fasteners		Tension Load	Deflection at ASD Load ⁷	Tension Load	Deflection at LRFD Load ⁷		
S/HDU4	7%	5/8	6-#14	2-33 (2-20ga)	2320	0.093	3705	0.149	5685	FC1
				2-43 (2-18ga)	3825	0.115	6105	0.190	9365	
				2-54 (2-16ga)	3970	0.093	6345	0.156	9730	
				Steel Fixture	4470	0.063	7165	0.103	12120	
S/HDU6	10%	5/8	12-#14	2-33 (2-20ga)	4895	0.125	8495	0.250	10470	
				2-43 (2-18ga)	6125	0.119	9690	0.250	15460	
				2-54 (2-16ga)	6125	0.108	9785	0.234	15005	
				Steel Fixture	5995	0.060	9580	0.136	14695	
S/HDU9	12%	7/8	18-#14	2-33 (2-20ga)	6965	0.103	11125	0.189	13165	
				2-43 (2-18ga)	9255	0.125	15485	0.250	21810	
				2-54 (2-16ga)	9990	0.106	15960	0.225	24480	
				Steel Fixture	12715	0.125	20510	0.177	31455	
S/HDU11	16%	7/8	27-#14	2-33 (2-20ga)	6965	0.103	11125	0.189	13165	
				2-43 (2-18ga)	9595	0.096	15330	0.162	23515	
				2-54 (2-16ga)	9675	0.110	15460	0.158	23710	
		w/ heavy hex nut	27-#14	2-43 (2-18ga) ⁶	11100	0.125	17500	0.250	24955	
				2-54 (2-16ga) ⁶	12175	0.125	19445	0.243	29825	
				Steel Fixture ⁶	12945	0.111	20680	0.163	31715	

1. Designer shall specify the foundation anchor material type, length, embedment and configuration. Tabulated loads may exceed anchor bolt ASTM A36 or A307 tension capacities.
2. See pages 26-30 for anchor bolt options.
3. See page 21 for anchor bolt retrofit options.
4. Stud design by Specifier. Tabulated loads are based on a minimum studs thickness for fastener connection.
5. 1/4" self-drilling tapping screws can be substituted for #14.
6. Heavy hex nut is required to achieve the table loads for S/HDU11.
7. Deflection at ASD and LRFD Loads includes fastener slip, holdown elongation and anchor bolt elongation (L=4").
8. Nominal Tension Load is based on the average ultimate (peak) load from tests. AISI Lateral Design standard requires holdown to have nominal strength to resist lesser of amplified seismic load or the maximum force the system can deliver.

HTT, S/LTT & S/HTT Tension Ties

The HTT and S/HTT is a single-piece formed tension tie—no rivets, and a 4-ply formed seat. No washers are required.

The S/LTT, S/HTT and HTT Tension Ties are ideal for retrofit or new construction projects. They provide high-strength, post-pour, concrete-to-steel connections.

MATERIAL: S/HTT14, HTT4, HTT5 111 mil (11 ga)
S/LTT20B – Strap: 97 mil (12 ga)
Plate: 229 mil (3 ga)

FINISH: Galvanized

INSTALLATION: • Use all specified fasteners.

- Use the specified number and type of screws to attach the strap portion to the steel stud. Bolt the base to the wall or foundation with a suitable anchor; see table for the required bolt diameter.
- Do not install S/LTT20 raised off of the bottom track.

CODE: See page 8 for Code Listing Key Chart.

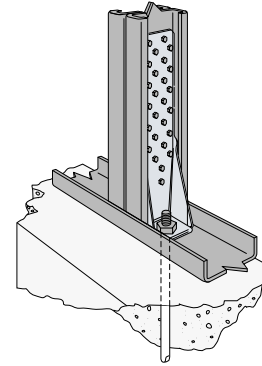

Typical HTT5 Installation as a Holddown

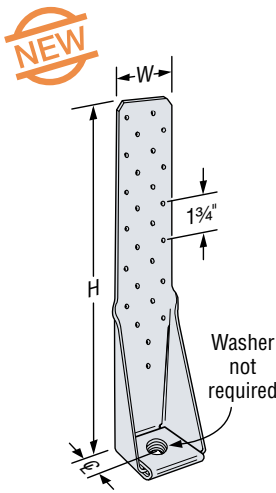

HTT5

(HTT4 similar)

U.S. Patent 5,467,570

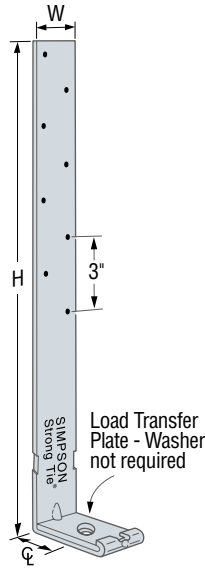

S/LTT20

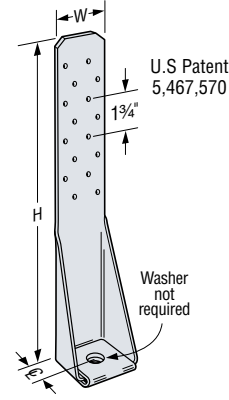

S/HTT14

Available with additional corrosion protection. Check with Simpson Strong-Tie.

Model	Dimensions			Fasteners		Stud Member Thickness mil (ga)	ASD		LRFD		Nominal Tension Load ⁶	Code Ref.
	W	H	CL	Found. Anchor Diameter	Stud Fasteners		Tension Load	Deflection at ASD Load ⁵	Tension Load	Deflection at LRFD Load ⁵		
S/LTT20	2	20	1½	½	8 - #10	33 (20ga)	1200	0.125	1890	0.250	4625	ILC1, LC1, FC1
S/HTT14	2½	16	1¾	⅝	16 - #10	33 (20ga)	2775	0.108	4430	0.172	6800	
HTT4	2½	12¾	1¾	⅝	18 - #10	2-33 (2-20ga)	3850	0.125	6700	0.250	11590	160
						33 (20ga)	3180	0.104	4770	0.187	8215	
HTT5	2½	16	1¾	⅝	26 - #10	2-33 (2-20ga)	4395	0.125	6675	0.250	11835	
						43 (18ga)	4240	0.125	6505	0.250	11585	
						2-43 (2-18ga)	4670	0.125	6970	0.250	12195	
						1-54 (1-16ga)	4150	0.125	6425	0.250	12365	

1. The Designer shall specify the anchor embedment and configuration.
2. See pages 26–30 for anchor bolt options.
3. See page 21 for anchor bolt retrofit options.
4. Stud design by Specifier. Tabulated loads are based on a minimum stud thickness for fastener connection.
5. Deflection at ASD and LRFD Loads is the deflection of the holddown measured between the anchor bolt and strap portion of the holddown when loaded to the ASD and LRFD load, respectively. This movement is strictly due to the holddown deformation under a static load test attached to members listed in the table.
6. Nominal Tension Load is based on the average ultimate (peak) load from tests. AISI Lateral Design standard requires holddown to have nominal strength to resist lesser of amplified seismic load or the maximum force the system can deliver.



S/HDS & S/HDB Holdowns

The S/HD series of holdowns is designed for installation with either screws or bolts into the studs or column. The S/HDS series installs with #14 screws and has been designed to utilize fewer fasteners to reduce installation time. The S/HDB series is ideal for bolt-on applications where the cold-formed stud manufacturer can pre-punch the bolt holes.

MATERIAL: See table

FINISH: Simpson Strong-Tie gray paint. Hot-dip galvanized is available; see Corrosion-Information, page 12–13.

INSTALLATION: • Use all specified fasteners; some models have extra fastener holes. See General Notes.

- Anchor bolt washer is not required.
- Standard washers are required on stud bolt nuts for model S/HDB.
- Thin wall socket (OD=2" maximum) is required for S/HD15 to tighten the 1" anchor bolt.
- Stud bolts – use A307.
- Boundary members (*back-to-back studs*) design shall be by Designer.
- S/HDS and S/HDB holdowns can be welded per Designer's recommendation and specification. To tie back-to-back stud members together, the Designer must determine the fasteners required to bind members to act as one unit. Welders and welding procedures shall be qualified as specified in AWS D1.3. Welded connections used for cold-formed steel structural members in which the thickness of the thinnest connected part is 0.18 inch or less shall comply to 2001 AISI NAS Specification Section E2.

CODE: See page 8 for Code Listing Key Chart.

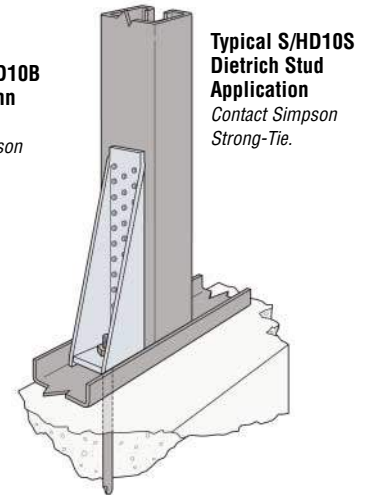
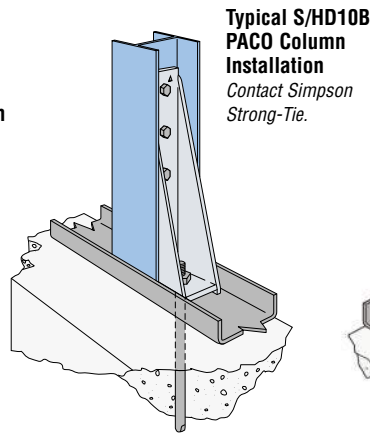
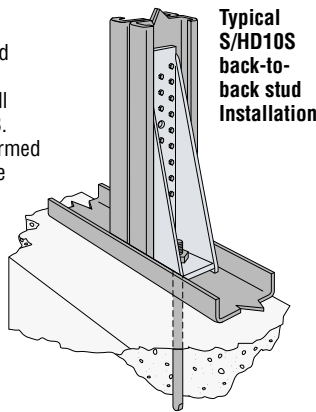
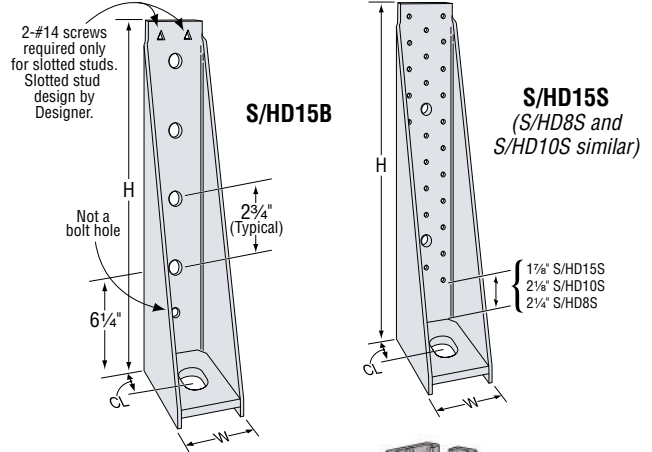

Holdowns & Tension Ties

Available with additional corrosion protection. Check with Simpson Strong-Tie.

Model	H	Fasteners		Stud Member Thickness mil (ga) ⁴	ASD		LRFD		Nominal Tension Load ⁷	Code Ref
		Found. Anchor Diameter ¹	Stud Fasteners		Tension Load	Deflection at ASD Load ⁶	Tension Load	Deflection at LRFD Load ⁶		
S/HD8S	11	¾"	17 - #14	2-33 (2-20ga)	7335	0.120	11715	0.204	13720	FC1
				2-43 (2-18ga)	8750	0.086	13975	0.146	21435	
				2-54 (2-16ga)	8855	0.106	14145	0.162	21700	
				Steel Fixture	10840	0.053	17335	0.072	32525	
S/HD10S	13½"	¾"	22 - #14	2-33 (2-20ga)	7400	0.122	11815	0.192	13835	
				2-43 (2-18ga)	11120	0.112	17755	0.124	20795	
				2-54 (2-16ga)	12220	0.096	19520	0.145	29940	
				Steel Fixture	12375	0.043	19820	0.061	33535	
S/HD15S	17"	1"	30 - #14	2-43 (2-18ga)	12110	0.096	19340	0.164	22645	
				2-54 (2-16ga)	13500	0.110	21565	0.130	33075	
				Steel Fixture	15810	0.043	25320	0.065	42845	
S/HD8B	11"	¾"	2 - ¾" Dia	2-33 (2-20ga)	3895	0.081	5620	0.144	8645	
				2-43 (2-18ga)	5345	0.098	7710	0.146	11865	
				2-54 (2-16ga)	8950	0.082	14280	0.141	20310	
				Steel Fixture	9080	0.069	14545	0.104	22975	
S/HD10B	13½"	¾"	3 - ¾" Dia	2-33 (2-20ga)	5840	0.070	8430	0.124	12970	
				2-43 (2-18ga)	8015	0.087	11565	0.120	17795	
				2-54 (2-16ga)	12090	0.125	19720	0.230	28050	
				Steel Fixture	15635	0.102	24955	0.123	35495	
S/HD15B	17"	1"	4 - ¾" Dia	2-43 (2-18ga)	10690	0.118	15425	0.179	22165	
				2-54 (2-16ga)	16020	0.090	25565	0.121	36360	
				Steel Fixture	18690	0.104	29825	0.139	42425	

1. Designer shall specify the foundation anchor material type, length, embedment and configuration. Tabulated loads may exceed anchor bolt ASTM A36 or A307 tension capacities.
2. See pages 26–30 for anchor bolt options.
3. See page 21 for anchor bolt retrofit options.
4. Stud design by Specifier. Tabulated loads are based on a minimum studs thickness for fastener connection.
5. ¼" self-drilling screws can be substituted for #14.

6. Deflection at ASD and LRFD Loads includes fastener slip, holdown elongation and anchor bolt elongation (L=4").
7. Nominal Tension Load is based on the average ultimate (peak) load from tests. AISI Lateral Design standard requires holdown to have nominal strength to resist lesser of amplified seismic load or what the system can deliver.

STHD Strap Tie Holdown

Holdowns & Tension Ties

The STHD is an embedded strap tie holdown with high load capacity and designed to reduce spalling.

- FEATURES:**
- A slot below the embedment line allows for increased front to back concrete bond and reduced spalling.
 - Rim joist models accommodate up to a 17" clear span without any loss of strap fastening. Diamond holes for optional attachment to rim joist.

MATERIAL: 68 mil (12 ga) **FINISH:** Galvanized

INSTALLATION: • Use all specified fasteners. See General Notes.

- Install before concrete pour with a StrapMate, or other holding device.
- Screw strap from the bottom up. Strap may be bent one full cycle.
- Bending the strap 90° to aid wall placement may cause spalling behind the strap. If the spall is 1" or less, measured from the embedment line to the bottom of the spall, full loads apply. For spalls between 1" and 4" (see illustration), the allowable load is 0.90 of the table loads. Any portion of the strap left exposed should be protected against corrosion.
- Where fewer fasteners are used in the structural member, reduce loads according to the code.
- Unless otherwise noted, do NOT install where: (a) a horizontal cold joint exists within the embedment depth between the slab and foundation wall or footing beneath, unless provisions are made to transfer the load, or the slab is designed to resist the load imposed by the anchor; or (b) slabs are poured over concrete block foundation walls.
- To get the full table load, the minimum center-to-center spacing is twice the embedment depth when resisting tension loads at the same time.
- There may be an increase in the amount of deflection if the strap is installed on the outside of the shear panel versus under the shear panel directly to the framing.

FOUNDATION CORNERS: Screw quantities may be reduced for less than l_e corner distance design loads—use the code allowable loads for fasteners in shear.

- To tie multiple stud members together, the Designer must determine the fasteners required to bind members to act as one unit.
- Additional studs attached to the shearwall studs or post may be required by the Designer for wall sheathing fastener.
- 1- #4 rebar must be installed in the shear cone

CODES: See page 8 for Code Listing Key Chart

NEW FEATURES ON THE STHD STRAP TIE HOLDOWNS

- Built-in tab StrapMate®**
Additional diamond hole in RJ versions

BENEFITS

- Built-in Tab:**
- Reduces spalling and costly retrofits
 - No additional labor to install
 - Hold STHD away from form board
- StrapMate Locator Line:**
- Easy inspection to ensure proper location
 - Allows adjustment without removing STHD
- Additional Diamond Hole:**
- One more fastener to help prevent the STHD RJ models from bowing out at the rim joist section

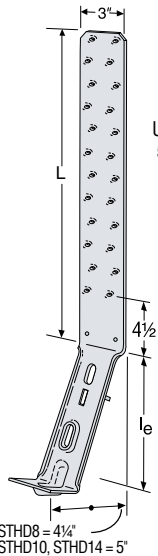
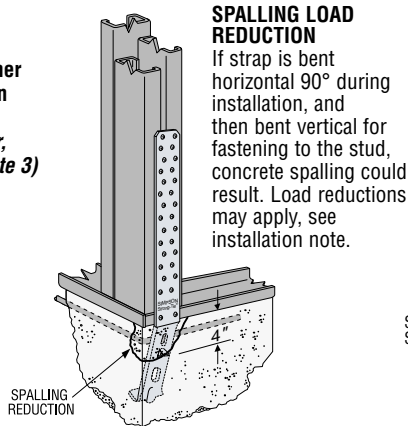
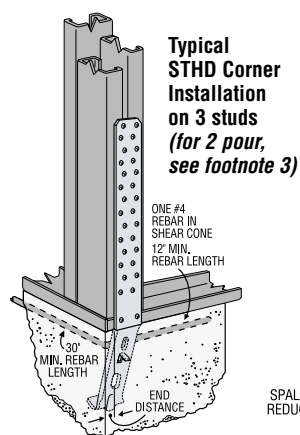
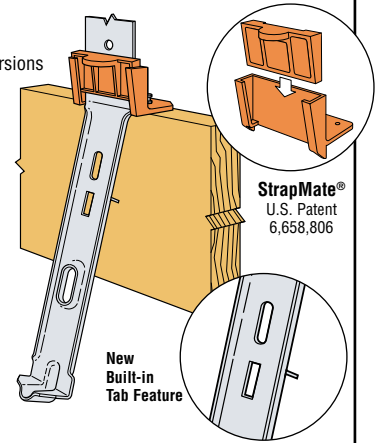

STHD
U.S. Patent
5,813,182

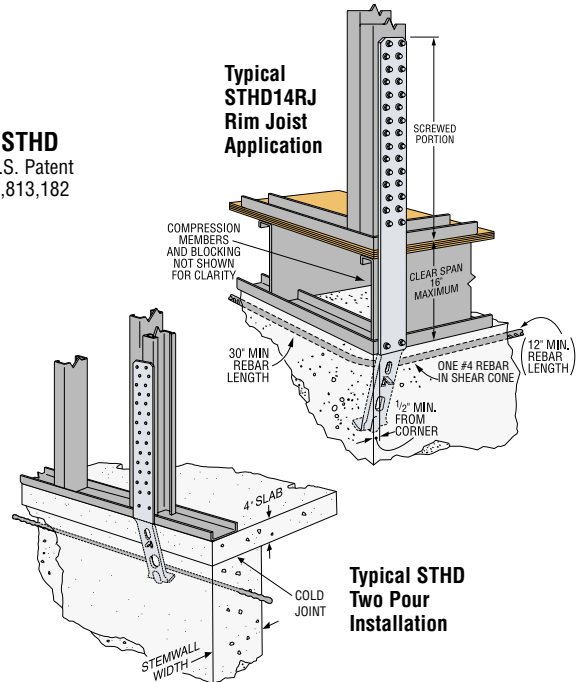

Typical STHD Two Pour Installation

Model No. Standard / Rim Joist	Min Stem Wall Width	Strap Length (L)		l_e	Screws	Allowable ASD Tension Loads 33 mil (20 ga)									Code Ref
		Std Model	Rim Joist Model			End Distance									
						2000 psi Concrete			2500 psi Concrete			3000 psi Concrete			
						1/2"	1 1/2"	l_e	1/2"	1 1/2"	l_e	1/2"	1 1/2"	l_e	
STHD8 / STHD8RJ	6	21 3/8"	35 1/8"	8	18-#10	1760	2050	2345	1950	2210	2345	2135	2425	2425	ILC1, FC1
STHD10 / STHD10RJ	6	23 3/8"	36 3/8"	10	22-#10	2035	2575	3295	3730	3730	3730	3730	3730	3730	
STHD14 / STHD14RJ	6	31 3/8"	39 3/8"	14	30-#10	3235	4220	4805	5025	5025	5025	5025	5025	5025	
STHD8 / STHD8RJ	8	21 3/8"	35 1/8"	8	18-#10	2170	2170	3180	2370	2370	3180	2370	2370	3180	
STHD10 / STHD10RJ	8	23 3/8"	36 3/8"	10	22-#10	2745	2745	3725	3730	3730	3730	3730	3730	3730	
STHD14 / STHD14RJ	8	31 3/8"	39 3/8"	14	34-#10	3885	4430	5785	5025	5025	5785	5025	5025	5785	

1. 'RJ' after the model indicates STHDs for rim joist applications, e.g. STHD8RJ.
2. For two pour with 4" slab or less. The STHD14 load at 1/2" edge 2000 psi is 2035 lbs. The STHD10 at the same condition is 2035 lbs.
3. Not all fastener holes need to be filled as additional fastener holes provided. Install fasteners symmetrically.
4. Table loads apply to end installation applications provided there is a minimum end distance of l_e .

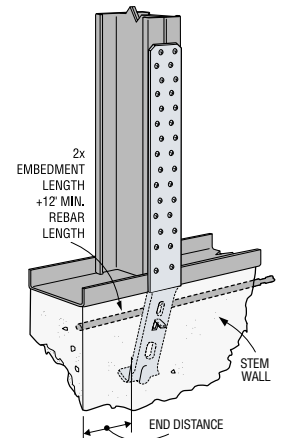

Typical STHD End Installation (see footnote 6)

STHD Strap Tie Holdown

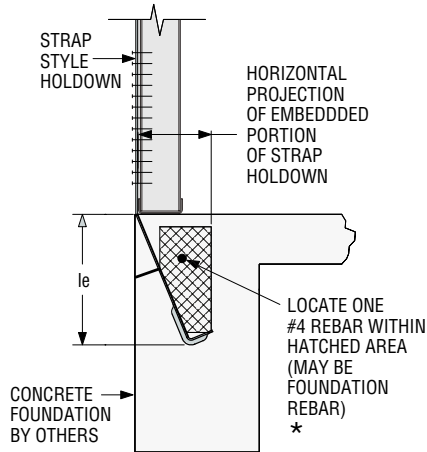

Single Pour Rebar Installation
**Maintain minimum rebar cover, per ACI-318 concrete code requirements.*

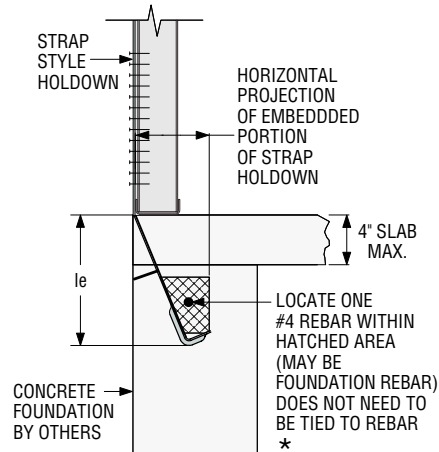

Two Pour Rebar Installation
**Maintain minimum rebar cover, per ACI-318 concrete code requirements.*

Holdowns & Tension Ties

POST-TENSION INFORMATION

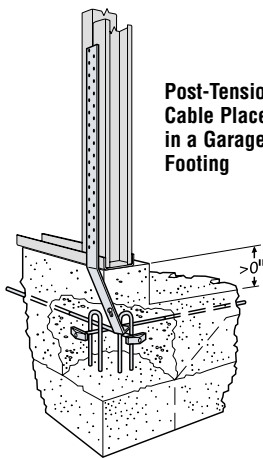

DETAIL 1
When installed on a raised curb, use stemwall installation and loads (see pages 29-31) (rebar required)

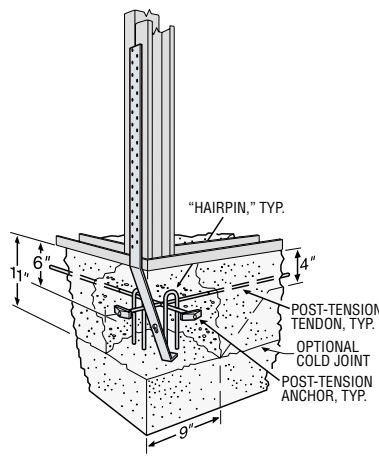

DETAIL 2
Post-Tension Cable Placement Corner Installation (no rebar required)

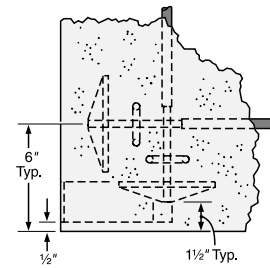

Top View of Post-Tension Cable Placement

C-CFS10 © 2010 SIMPSON STRONG-TIE COMPANY INC.

Model No.	Distance from Corner	Fasteners			Allowable ASD Tension Loads	Code Ref.
		33 mil (20 ga)	43 mil (18 ga)	54 mil (16 ga)		
S/HPAHD22	½" Min	16- #10	11- #10	6- #10	2705	170
	8" Min	25- #10 ⁵	23- #10	23- #10	4740 ⁵	
STHD8/ STHD8RJ	½" Min	12- #10	8- #10	4- #10	2055	
	8" Min	16- #10	11- #10	6- #10	2780	
STHD10/ STHD10RJ	½" Min	12- #10	8- #10	4- #10	2055	
	10" Min	19- #10	13- #10	7- #10	3240	

1. Minimum concrete strength is 2500 psi.
2. Post-tension steel is minimum ½" diameter, 7-wire, low-relaxation strand in accordance with ASTM A416, Grade 270 ksi, with a guaranteed ultimate strength of 41.3 k.
3. Anchorage is monostrand-type anchor system with current ICC approval using a ductile iron casting of at least 2.25" x 4.5" of bearing and reusable pocket formers on all stressing ends.
4. It is the designer's responsibility to provide reinforcement to tie cold-joints and to resist bending stresses in the foundation due to anchor uplift.
5. For S/HPAHD attaching to 33 mil (20 ga) CFS, the allowable load is 4420 lbs.

S/PAHD & S/HPAHD Strap Tie Holdowns

Holdowns & Tension Ties

A variety of steel-to-concrete connectors that satisfy engineering and code requirements. Allowable loads include a tested three-times safety factor in concrete with a one-piece design and no separate anchors required.

MATERIAL: S/HPAHD, HPAHD—118mil (10 ga) x 2 1/16"; S/PAHD—97 mil (12 ga) x 2 1/16".

FINISH: Galvanized; see Corrosion Information, page 12–13.

INSTALLATION: • Use all specified fasteners.

- Unless otherwise noted, do NOT install where:
 - (a) a horizontal cold joint exists within the embedment depth between the slab and foundation wall or footing beneath, unless provisions are made to transfer the load, or the slab is designed to resist the load imposed by the anchor; or
 - (b) slabs are poured over concrete block foundation walls.
- To get the full table load, the minimum center-to-center spacing is twice the embedment depth when resisting tension loads at the same time.
- **FOUNDATION CORNERS:** Screw quantities have been reduced when the load is limited by tested concrete pullout strength. Additional screw holes need not be filled.

FEATURES: Designed to be installed at the edge of concrete. Tests determined the pullout strength with one horizontal #4 rebar in the shear cone. Install before concrete pour with a StrapMate®, or other holding device. Pre-bent to control the embedment at the required angle; field-bending is not necessary. Installation holes allow nailing to the form, resulting in 1" deeper embedment; see illustration.

OPTIONS: See also S/HD Holdowns, S/LTT, S/HTT and HTT Tension Ties.

CODE: See page 8 for Code Listing Key Chart.

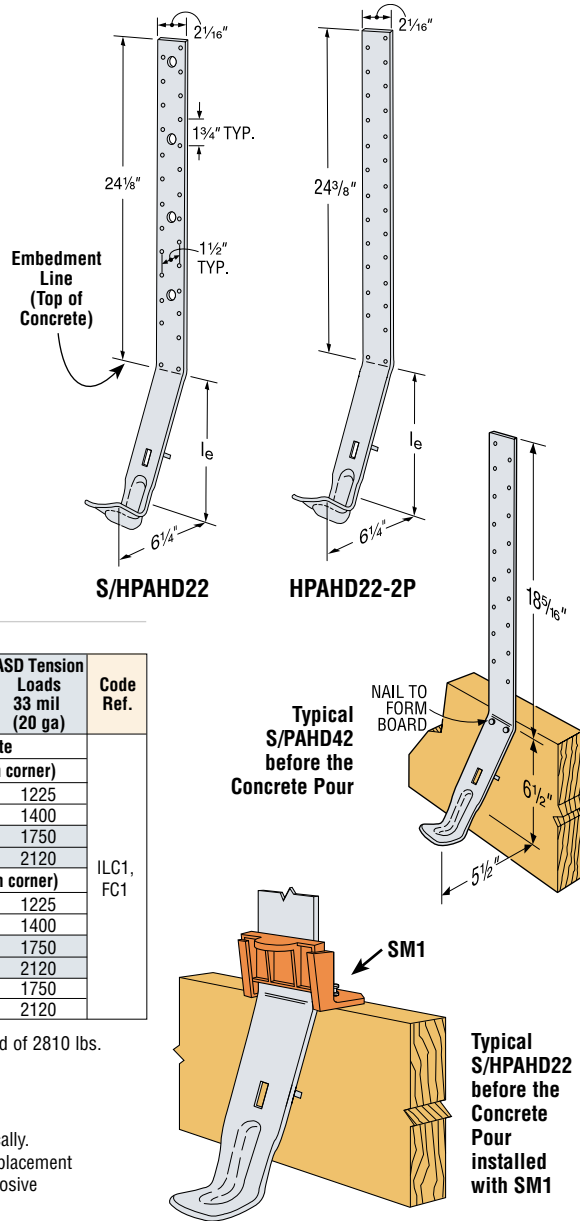

Model No.	Minimum Stemwall Width	Embed. Depth l_e	Screws	ASD Tension Loads 33 mil (20 ga)	Model No.	Minimum Stemwall Width	Embed. Depth l_e	Screws	ASD Tension Loads 33 mil (20 ga)	Code Ref.	
Edge Installation – 2500 psi Concrete					Corner Installation – 2500 psi Concrete						
Single Pour – see installation 1 (8" min from corner)					Single Pour – see installation 2 (1/2" min from corner)						
S/PAHD42	6	6 1/2"	10- #10	1765	S/PAHD42	6	6 1/2"	4- #10	1225	ILC1, FC1	
	8		13- #10	2300		5- #10		1400			
S/HPAHD22	6	10"	20- #10	3335	S/HPAHD22	6	10"	10- #10	1750		
	8		26- #10	4595		12- #10		2120			
Double Pour – see installation 3 (8" min from corner)					Double Pour – see installation 4 (1/2" min from corner)						
S/PAHD42	6	6 1/2"	10- #10	1765	S/PAHD42	6	6 1/2"	4- #10	1225		
	8		13- #10	2300		5- #10		1400			
S/HPAHD22	6	10"	20- #10	3335	S/HPAHD22	6	10"	10- #10	1750		
	8		26- #10	4595		12- #10		2120			
HPAHD22-2P	6	14 7/16"	20- #10	3335	HPAHD22-2P	6	14 7/16"	10- #10	1750		
	8		26- #10	4595		12- #10		2120			

1. S/HPAHD22 may be embedded 4" into the slab and 6" into the 8" stemwall beneath for a maximum load of 2810 lbs. at 8" minimum from the closest corner, and 1400 lbs. at 1/2" from the closest corner. See Installation 4.
2. Calculate the loads using straight line interpolation for corner distances between 1/2" and 8".
3. Loads are based on CFS members having a minimum thickness of 33 mil (20 ga).
4. Not all fastener holes need to be filled as additional fastener holes provided. Install fasteners symmetrically.
5. Strap may be bent one full cycle. (*Bent horizontal 90° then bent vertical.*) Bending the strap to aid wall placement may cause spalling behind the strap. Any portion of the strap exposed should be protected against corrosive conditions with industry standard practices.

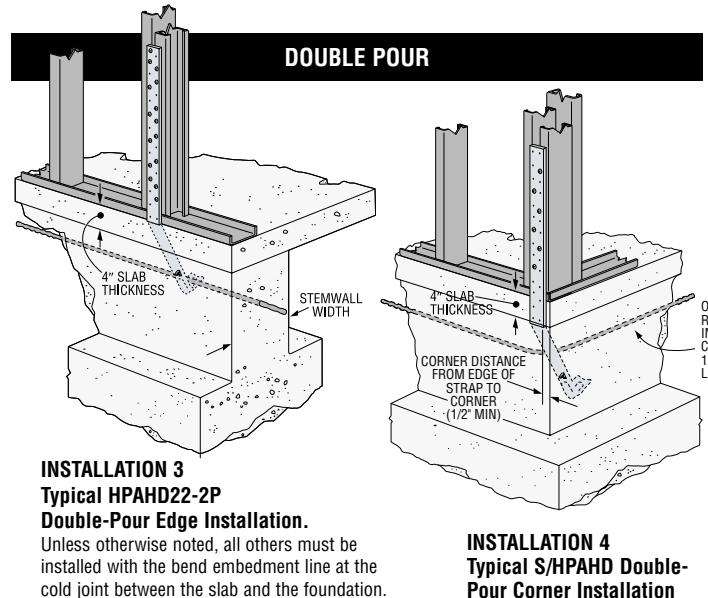
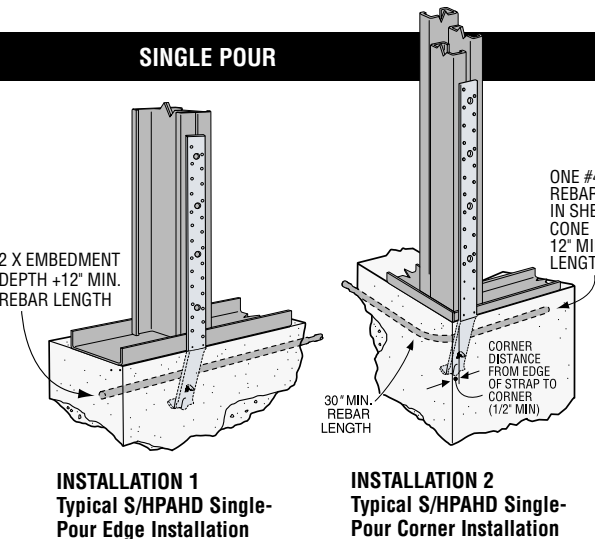

PA/HPA Strap Tie Holdowns

Holdowns & Tension Ties

Cold-formed steel-to-concrete and concrete-block connectors that satisfy code requirements.

The PA's dual embedment line allows installation in concrete or concrete block.

MATERIAL: See table

FINISH: Galvanized. PA's available hot-dip galvanized (HDG) or ZMAX®. See Corrosion Information page 12-13.

INSTALLATION: • Minimum concrete strength is 2000 psi.
• Use all specified fasteners; some models have extra fastener holes. See General Notes.
• Purlin Anchor must hook around rebar.

EDGE DISTANCE—Minimum concrete edge distance is 5".
Minimum concrete block left-to-right edge distance is 20".

CONCRETE BLOCK WALL—The masonry embedment line on the PA allows for 4" of grout embedment in a standard 8" concrete masonry unit. The minimum wall specifications are (see drawing at right):

- A One #4 vertical rebar, 32" long, 16" each side of anchor;
- B Two courses of grout filled block above and below the anchor (no cold joints allowed);
- C A horizontal bond beam with two #4 rebars, 40" long, a maximum of two courses above or below the anchor.

All cells grouted with 2000 psi 3/8" aggregate grout. Grout shall be vibrated per the code. Rebar quantities, sizes and lengths are minimum requirements and may be increased per any additional wall design requirements.

OPTIONS: See S/LTT, S/HTT and HTT Tension Ties.

CODES: See page 8 for Code Listing Key Chart.

The IBC 1620.2.1 states:

... Diaphragm to wall anchorage using embedded straps shall have the straps attached to or hooked around the reinforcing steel, or otherwise terminated to effectively transfer forces to the reinforcing steel.

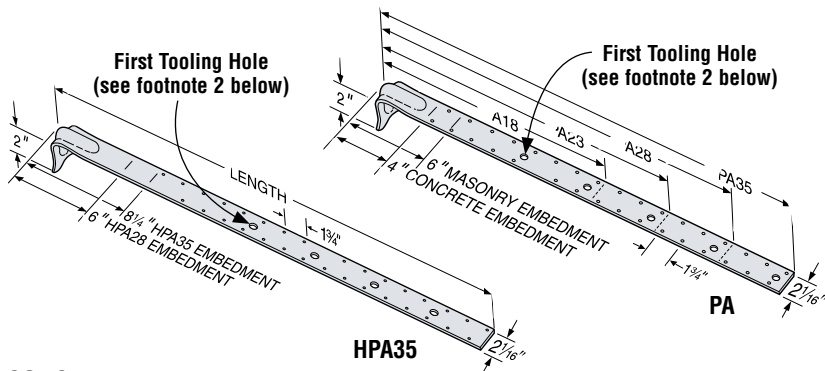
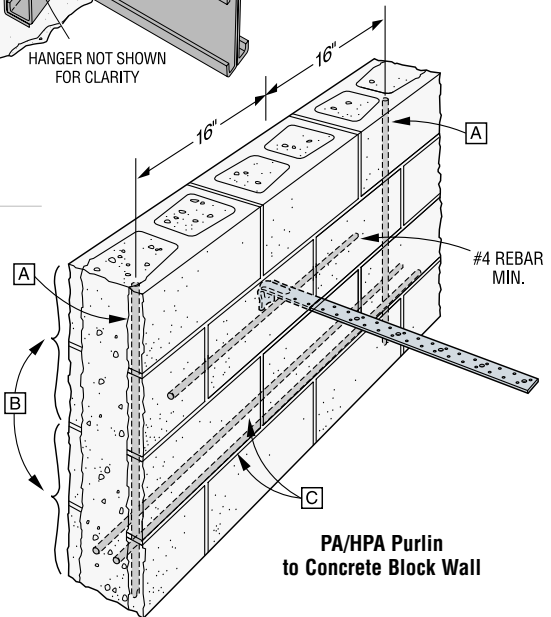
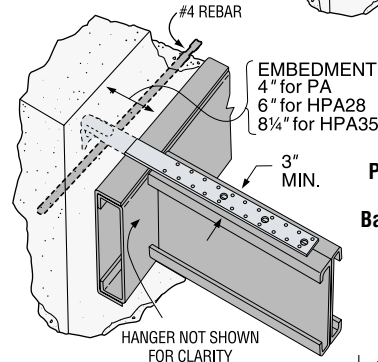
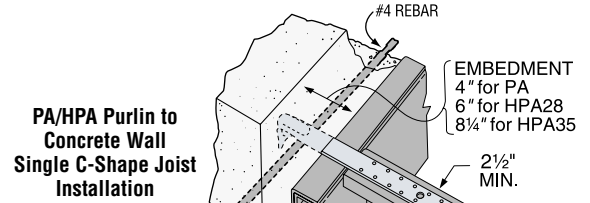

CONCRETE

Available with additional corrosion protection. Check with Simpson Strong-Tie.

Model No.	Connector Material Thick. mil (ga)	L	W	Fasteners			Allowable ASD Tension Loads			Code Ref.
				Rafter/Stud/Joist Thickness			33 mil (20 ga)	43 mil (18 ga)	54 mil (16 ga)	
				33 mil (20 ga)	43 mil (18 ga)	54 mil (16 ga)				
PA18	97 (12 ga)	18 1/2	2 1/16	16- #10	16- #10	8- #10	2830	3685	3685	FC1
PA23		23 3/4		22- #10	16- #10	8- #10	3685	3685	3685	
PA28		32 1/2		22- #10	16- #10	8- #10	3685	3685	3685	
HPA28	118 (10 ga)	21 1/2	2 1/16	22- #10	16- #10	8- #10	3685	3685	3685	
HPA35		38 1/2		28- #10	20- #10	10- #10	4845	4845	4845	
HPA35				32- #10	22- #10	12- #10	5420	5420	5420	

MASONRY

Model No.	Connector Material Thick. mil (ga)	L	W	Fasteners			Allowable ASD Tension Loads			Code Ref.
				Rafter/Stud/Joist Thickness			33 mil (20 ga)	43 mil (18 ga)	54 mil (16 ga)	
				33 mil (20 ga)	43 mil (18 ga)	54 mil (16 ga)				
PA18	97 (12 ga)	18 1/2	2 1/16	16- #10	12- #10	6- #10	2815	2815	2815	FC1
PA23		23 3/4		16- #10	12- #10	6- #10	2815	2815	2815	
PA28		32 1/2		16- #10	12- #10	6- #10	2815	2815	2815	
PA35		35		16- #10	12- #10	6- #10	2815	2815	2815	

1. Allowable loads are for a horizontal installation into the side of a concrete or masonry wall.
2. Install a minimum of 4 of the required fasteners between the embedment line and the first tooling hole.
3. Not all fastener holes need to be filled as additional fastener holes provided. Install fasteners symmetrically.

ICFVL Ledger Connector System

The ICFVL Ledger Connector System is engineered to solve the challenges of mounting CFS ledgers to insulated concrete form (ICF) walls. The ICFVL is designed to provide both vertical and lateral, in-plane performance. There are many benefits over traditional anchor bolting, including better on-center spacing in most cases, faster installation and no protrusions.

The embedded legs of the ICFVL are embossed for additional stiffness and the hole allows for concrete to flow through and around the connector. The exposed flange on the face of the ICF provides a structural surface for mounting a CFS ledger.

MATERIAL: ICFVL—68 mil (14 ga)

FINISH: Galvanized

INSTALLATION: ICFVL in ICF

- Snap a chalk line for the bottom of the ledger.
- Mark required on-center spacing.
- Use ICFVL to mark kerf locations.
- Cut kerfs as marked.
- Insert ICFVL flush to the face of the ICF.
- Pour concrete.

CFS Ledger Attachment

- Position the ledger level to the chalk line and against the ICFVL.
- Attach with four #14x¾", #3 drill point screws (*not provided*).
- All screws should be located at least ½" from the edge of the ICFVL.
- Space screws evenly.

CODES: See page 8 for Code Listing Key Chart.

WARNING:
Industry studies show that hardened fasteners can experience performance problems in wet environments. Accordingly, use this product in dry environments only.

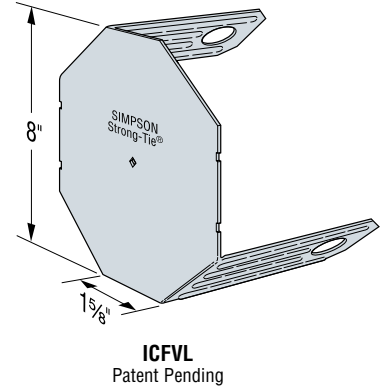

Model No.	Fasteners	Allowable ASD Loads (lbs)	
		Download	Lateral F ₁
ICFVL	4-#14x¾"	54 mil (16 ga)	68 mil (14 ga)
		1660	1525

1. Fasteners for CFS ledger are not provided.
2. Loads apply to ICF foam thicknesses of 2¾" or less. Contact Simpson Strong-Tie for allowable loads on thicker walls.
3. Alternately, ¼" x ¾" fastener may be used.
4. Concrete f'c = 2500 psi minimum.
5. When combining download and lateral loads, Designer shall evaluate as follows: Design Download/Allowable Download + Design Lateral Load/Allowable Lateral Load ≤ 1.

These tables address vertical load applications only.

Ledger Material Thickness mil (ga)	Connector Type	ICFVL Spacing to Replace Anchor Bolts on a CFS Ledger (in) ^{1,2,3}								Code Ref.
		½" Dia. Anchors at				⅝" Dia. Anchors at				
		12" o.c.	24" o.c.	36" o.c.	48" o.c.	12" o.c.	24" o.c.	36" o.c.	48" o.c.	
68 (14 ga)	ICFVL	11	22	33	44	9	18	27	36	170
54 (16 ga)	ICFVL	15	30	45	48	12	24	36	48	

1. The Designer may specify different spacing based on the load requirements.
2. See flier F-ICFVL for additional connection details.
3. CFS ledger values are based on steel Fu = 65 ksi.

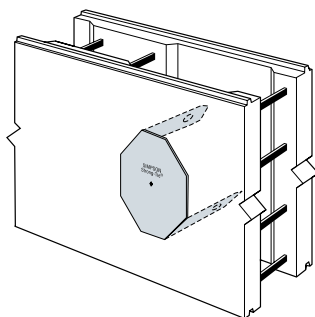

ICFVL

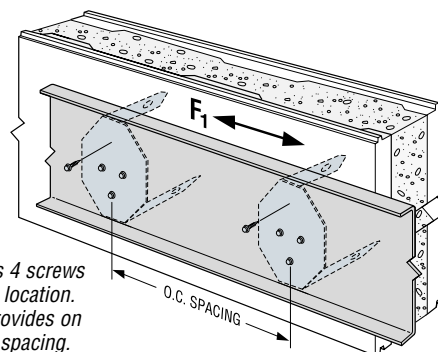

Requires 4 screws at each location. Table provides on center spacing.

Typical CFS Ledger Installation with ICFVL (minimum 54 mil)



The Strong Frame Ordinary Moment Frame Catalog

All of the information you need on our latest lateral force-resisting solution is contained in the *Strong Frame Ordinary Moment Frame* catalog. Frame and anchorage design information, installation instructions, prescriptive wall bracing requirements and installation details are all included in this useful tool. Visit www.strongtie.com to download or request a copy or call (800) 999-5099.

For years moment frames have been a common method of providing high lateral-force resistance when limited wall space and large openings control the structural design. Traditionally, the disadvantage with moment frames has been that they are time-intensive to design and labor-intensive to install. Simpson Strong-Tie has taken these factors into consideration and has created a cost-effective alternative to traditional frames – the Strong Frame ordinary moment frame. For CFS applications, the Strong Frame ordinary moment frame is available without the pre-installed wood nailers.



FEATURES:

- **Pre-designed moment frame solutions:** Designers can choose from 196 engineered frames, in sizes up to 16 feet wide and 19 feet tall, rather than having to spend hours designing one.
- **100% bolted connections:** Install frames faster with no field welding required. No need to have a welder on site, or a welding inspector.
- **Frames fit in a standard 2x6 wall:** No thicker walls additional framing or furring required.
- **Greater quality control:** Frames are manufactured in a quality-controlled environment and field-bolted connections eliminate questions about field welds.
- **Convenient to store, ship and handle:** Disassembled frames are more compact, minimizing deliveries and simplifying handling on the jobsite.
- **Pre-assembled anchor-bolt assemblies:** Anchor bolts are pre-assembled on a shear-lug plate that mounts on the form. This helps ensure correct anchor placement and creates more efficient anchor performance.
- **Streamlined anchorage design:** No more tedious anchorage calculations – select an anchorage solution for your footing geometry from the anchorage tables and you are done.
- **Post-installed anchorage solutions available for prescriptive applications:** Simpson Strong-Tie® epoxy anchor solutions for higher load applications and solutions with the Simpson Strong-Tie Titen HD® screw anchor for prescriptive or lower-load applications.



Strong Frame OMFSL anchorage assemblies make design and installation faster and easier

STEEL STRONG-WALL®: Cold-Formed Steel on Concrete Foundations

The Steel Strong-Wall® provides high-capacity, narrow wall solutions for cold-formed steel framing. The wall installs easily in cold-formed steel framing, and pre-attached steel studs allow easy attachment of interior and exterior finishes.

MATERIAL: Vertical Panel—118 mil (10 ga)

FINISH: Vertical Panel—Galvanized
Top and Base Plates—Simpson Strong-Tie gray paint
(cold galvanizing available, contact Simpson Strong-Tie)

- NOTES:**
- For top-of-wall attachment, use ¼" or #14 self-drilling screws (not provided) extended through the connection with 3 exposed threads minimum. Fill all screw holes.
 - Maximum height H is the maximum height allowed for the allowable shear loads.

CODES: ICC-ES ESR-1679; City of L.A. RR 25625; State of Florida FL5113

Lateral Systems

STEEL STRONG-WALL FOR COLD-FORMED STEEL PRODUCT DATA

Model No.	W (in)	Max. H ¹ (in)	T (in)	Anchor Bolts		Number of Screws in Top of Wall
				Qty.	Dia.	
S/SSW12x7	12	80	3½	2	¾"	4
S/SSW15x7	15	80	3½	2	1"	6
S/SSW18x7	18	80	3½	2	1"	9
S/SSW21x7	21	80	3½	2	1"	12
S/SSW24x7	24	80	3½	2	1"	14
S/SSW12x8X	12	97	3½	2	¾"	4
S/SSW15x8X	15	97	3½	2	1"	6
S/SSW18x8X	18	97	3½	2	1"	9
S/SSW21x8X	21	97	3½	2	1"	12
S/SSW24x8X	24	97	3½	2	1"	14
S/SSW12x9X	12	109	3½	2	¾"	4
S/SSW15x9X	15	109	3½	2	1"	6
S/SSW18x9X	18	109	3½	2	1"	9
S/SSW21x9X	21	109	3½	2	1"	12
S/SSW24x9X	24	109	3½	2	1"	14
S/SSW15x10X	15	121	3½	2	1"	6
S/SSW18x10X	18	121	3½	2	1"	9
S/SSW21x10X	21	121	3½	2	1"	12
S/SSW24x10X	24	121	3½	2	1"	14

1. Specify height when ordering "X" models (example: S/SSW12x8X, H = 95").

NAMING SCHEME:

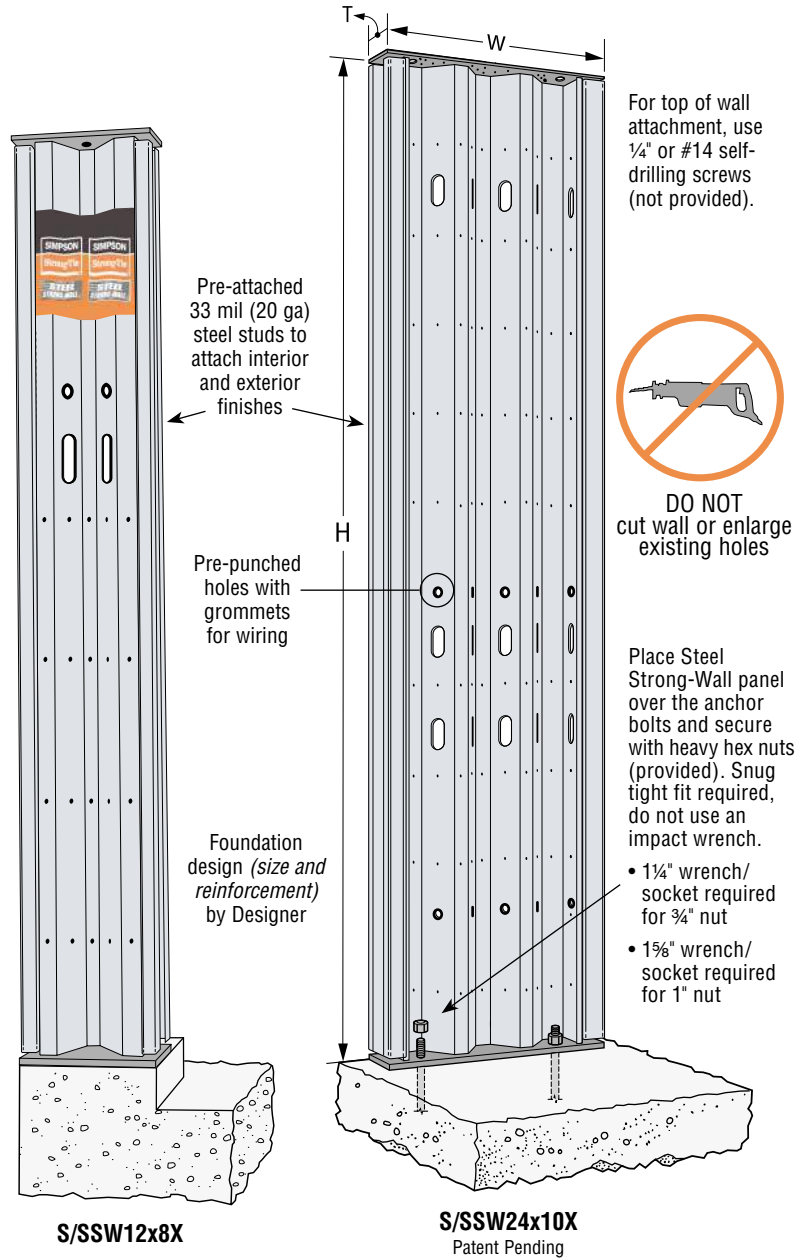
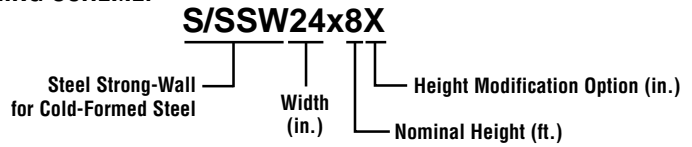

WALL PROFILES

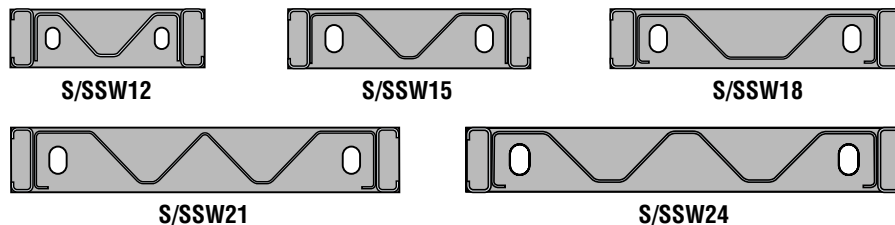

STEEL STRONG-WALL®: Cold-Formed Steel on Concrete Foundations

2006 INTERNATIONAL BUILDING CODE®

S/SSW Model	Max. H (in.)	Allowable Axial Load (lbs)	Seismic ²			Wind		
			Allowable ASD Shear Load V (lbs)	Drift at Allowable Shear (in)	Uplift at Allowable Shear ⁶ (lbs)	Allowable ASD Shear Load V (lbs)	Drift at Allowable Shear (in)	Uplift at Allowable Shear ⁶ (lbs)
S/SSW12x7	80	1000	845	0.35	8460	1070	0.44	11405
		4000	845	0.35	8460	1060	0.44	11265
		7500	845	0.35	8460	885	0.37	8950
S/SSW15x7	80	1000	1645	0.34	13340	1810	0.38	15135
		4000	1640	0.34	13290	1640	0.34	13290
		7500	1440	0.30	11290	1440	0.30	11290
S/SSW18x7	80	1000	2800	0.33	18690	3375	0.40	24545
		4000	2800	0.33	18690	3250	0.38	23135
		7500	2800	0.33	18690	2980	0.35	20370
S/SSW21x7	80	1000	4050	0.32	22590	4440	0.35	25710
		4000	4050	0.32	22590	4440	0.35	25710
		7500	4050	0.32	22590	4310	0.34	24635
S/SSW24x7	80	1000	5250	0.30	24710	5250	0.30	24710
		4000	5250	0.30	24710	5250	0.30	24710
		7500	5250	0.30	24710	5250	0.30	24710
S/SSW12x8X	97	1000	645	0.42	7710	820	0.54	10360
		4000	645	0.42	7710	775	0.51	9640
		7500	610	0.40	7220	610	0.40	7220
S/SSW15x8X	97	1000	1280	0.42	12390	1415	0.47	14090
		4000	1250	0.41	12025	1250	0.41	12025
		7500	1070	0.35	9955	1070	0.35	9955
S/SSW18x8X	97	1000	2140	0.41	16895	2785	0.54	24565
		4000	2140	0.41	16895	2680	0.52	23130
		7500	2140	0.41	16895	2460	0.48	20400
S/SSW21x8X	97	1000	3265	0.41	21905	3870	0.48	27930
		4000	3265	0.41	21905	3765	0.47	26790
		7500	3265	0.41	21905	3460	0.43	23715
S/SSW24x8X	97	1000	4540	0.39	26335	4985	0.43	30045
		4000	4540	0.39	26335	4890	0.42	29220
		7500	4540	0.39	26335	4555	0.39	26455
S/SSW12x9X	109	1000	545	0.48	7255	695	0.61	9735
		4000	545	0.48	7255	605	0.53	8210
		7500	445	0.39	5755	445	0.39	5755
S/SSW15x9X	109	1000	1090	0.48	11725	1180	0.52	12955
		4000	1025	0.45	10875	1025	0.45	10875
		7500	850	0.37	8720	850	0.37	8720
S/SSW18x9X	109	1000	1835	0.47	16105	2365	0.61	22835
		4000	1835	0.47	16105	2365	0.61	22835
		7500	1835	0.47	16105	2150	0.55	19890
S/SSW21x9X	109	1000	2800	0.46	20855	3275	0.54	25900
		4000	2800	0.46	20855	3025	0.50	23140
		7500	2735	0.45	20220	2735	0.45	20220
S/SSW24x9X	109	1000	4005	0.46	26025	4220	0.48	27970
		4000	3950	0.45	25540	3950	0.45	25540
		7500	3630	0.41	22855	3630	0.41	22855
S/SSW15x10X	121	1000	945	0.53	11185	990	0.56	11845
		4000	835	0.47	9645	835	0.47	9645
		7500	665	0.37	7425	665	0.37	7425
S/SSW18x10X	121	1000	1605	0.53	15515	2045	0.67	21490
		4000	1605	0.53	15515	1960	0.64	20225
		7500	1605	0.53	15515	1715	0.56	16890
S/SSW21x10X	121	1000	2440	0.52	19970	2650	0.56	22275
		4000	2405	0.51	19600	2405	0.51	19600
		7500	2120	0.45	16730	2120	0.45	16730
S/SSW24x10X	121	1000	3425	0.50	24275	3425	0.50	24275
		4000	3160	0.46	21875	3160	0.46	21875
		7500	2855	0.42	19275	2855	0.42	19275

NOTE:

For models with an "X" suffix, specify height when ordering (example: S/SSW12x8X, h=95").

- Allowable shear loads and anchor uplifts are applicable to installation on concrete with minimum $f'_c = 2500$ psi using the ASD basic (Section 1605.3.1) or the alternative basic (Section 1605.3.2) load combinations. Load values include evaluation of bearing stresses.
- For seismic designs based on the 2006 IBC using $R = 6.5$. For other codes, use the seismic coefficients corresponding to light-frame bearing walls with wood structural panels or sheet steel panels.
- Top-of-wall screws for the S/SSW shall be approved $\frac{1}{4}$ " or #14 self-drilling screws with a minimum nominal shear strength (Pss) of 2000 lbs. Top of panel shall be connected to a minimum 43 mil (18 ga) thick steel member typical. S/SSW18 and wider panels up to 97 inches tall require connection to a minimum 54 mil (16 ga) thick steel member. When connected to a minimum 43 mil (18 ga) thick steel member, the allowable load shall be limited to 2720 lbs. for S/SSW18, 3625 lbs. for S/SSW21, and 4230 lbs. for S/SSW24.
- Allowable shear, drift, and uplift values may be interpolated for intermediate height or axial loads. See example on page 42.
- High-strength anchor bolts are required for anchor tension (uplift) forces exceeding the allowable load for standard-strength bolts tabulated on pages 50–51. See pages 50–54 for SSWAB anchor bolt information and anchorage solutions.
- Tabulated anchor tension (uplift) loads assume no resisting axial load. For anchor tension loads at design shear values and including the effect of axial load, refer to the Strong-Wall Selector™ software or use the equations on page 43. Drifts at lower design shear may be linearly reduced.
- See page 42 for allowable out-of-plane loads and axial capacities.

STEEL STRONG-WALL®: Cold-Formed Steel on Concrete Foundations**ALLOWABLE OUT-OF-PLANE LOADS (PSF)^{1,3}**

Model Width	Axial Load (lbs) ^{2,4}	Nominal Height of Panel (feet)		
		8	9	10
12" wide	1000	195	140	100
	4000	145	100	70
	7500	85	50	25
15" wide	1000	160	125	100
	4000	130	95	70
	7500	90	65	45
18" wide	7500	300	210	155
21" wide	7500	255	180	130
24" wide	7500	265	190	135

1. Loads shown are at ASD level in pounds per square foot (psf) of wall with no further increase allowed and are applicable to either the ASD Basic or Alternative Basic load combinations.
2. Axial load denotes maximum gravity load permitted on entire panel acting in combination with the out-of-plane load.
3. Load considers a deflection limit of h/240.
4. Allowable out-of-plane loads for the 12- and 15-inch walls may be linearly interpolated between the axial loads shown.

AXIAL CAPACITIES ON CONCRETE

Model Width	Compression Capacity (lbs) with No Lateral Load ^{1,2,3}			
	Nominal Height of Panel (feet)			
	7	8	9	10
12" wide	20200	16300	13700	11100
15" wide	25300	21800	19200	16600
18" wide	42500	36000	31400	27000
21" wide	43700	35800	30300	25100
24" wide	51600	42900	36900	31100

1. Compression capacity is lesser of wall-buckling capacity or 2500 psi uniform concrete bearing.
2. Compression capacity of wall assumes concentric loading with no lateral loads present. See allowable in-plane or out-of-plane shear load tables for combined lateral and axial loading conditions.
3. Capacities are applicable to either the ASD Basic or Alternative Basic load combinations.

S/SSW SHEAR LOAD INTERPOLATION EXAMPLE**Given:**

2006 IBC, Seismic, 2500 psi Concrete

Shear Load = 2000 lbs.

Axial = 4000 lbs.

S/SSW Wall Height Required: 8'-6" = 102"

Interpolate (See table on page 30):

S/SSW18x8X $V_1 = 2140$ lbs., $h_1 = 97"$

S/SSW18x9X $V_2 = 1835$ lbs., $h_2 = 109"$

$$\text{Equation: } V_{\text{allow}} = \left(\frac{V_1 - V_2}{h_1 - h_2} \right) (h_{\text{required}} - h_1) + V_1$$

$$V_{\text{allow}} = \left(\frac{2140 \text{ lbs.} - 1835 \text{ lbs.}}{97" - 109"} \right) (102" - 97") + 2140 \text{ lbs.} = 2013 \text{ lbs. @ } 102"$$

$V_{\text{allow}} = 2013 \text{ lbs.} > 2000 \text{ lbs.}$ **OK**

>>> Use S/SSW18x9X H = 102"

EQUATIONS FOR CALCULATING UPLIFT FORCES AT BASE OF FIRST-STORY WALL*(Based on limiting concrete bearing on a 3½" wide base plate at the edge of the concrete)*

These equations may be used to calculate uplift forces at the base of the 1st-story wall to aid Designers in developing anchorage solutions other than those shown on pages 50–54.

NEW Equations have been revised and are based on a rectangular compression stress block.

2.5 ksi concrete

$$12 \text{ in. wall } T = \left[28.1 - \sqrt{788 - 5.95 (3.4P + Vh)} \right] - P$$

$$15 \text{ in. wall } T = \left[36.1 - \sqrt{1301 - 5.95 (4.6P + Vh)} \right] - P$$

$$18 \text{ in. wall } T = \left[45.0 - \sqrt{2025 - 5.95 (6.1P + Vh)} \right] - P$$

$$21 \text{ in. wall } T = \left[53.9 - \sqrt{2908 - 5.95 (7.6P + Vh)} \right] - P$$

$$24 \text{ in. wall } T = \left[62.8 - \sqrt{3950 - 5.95 (9.1P + Vh)} \right] - P$$

3.0 ksi concrete

$$12 \text{ in. wall } T = \left[33.7 - \sqrt{1135 - 7.14 (3.4P + Vh)} \right] - P$$

$$15 \text{ in. wall } T = \left[43.3 - \sqrt{1874 - 7.14 (4.6P + Vh)} \right] - P$$

$$18 \text{ in. wall } T = \left[54.0 - \sqrt{2916 - 7.14 (6.1P + Vh)} \right] - P$$

$$21 \text{ in. wall } T = \left[64.7 - \sqrt{4187 - 7.14 (7.6P + Vh)} \right] - P$$

$$24 \text{ in. wall } T = \left[75.4 - \sqrt{5688 - 7.14 (9.1P + Vh)} \right] - P$$

4.5 ksi concrete

$$12 \text{ in. wall } T = \left[50.5 - \sqrt{2554 - 10.71 (3.4P + Vh)} \right] - P$$

$$15 \text{ in. wall } T = \left[64.9 - \sqrt{4216 - 10.71 (4.6P + Vh)} \right] - P$$

$$18 \text{ in. wall } T = \left[81.0 - \sqrt{6560 - 10.71 (6.1P + Vh)} \right] - P$$

$$21 \text{ in. wall } T = \left[97.1 - \sqrt{9421 - 10.71 (7.6P + Vh)} \right] - P$$

$$24 \text{ in. wall } T = \left[113.1 - \sqrt{12,797 - 10.71 (9.1P + Vh)} \right] - P$$

Notes:

- Equations may be used to calculate uplift forces at the base of first-story walls on concrete foundations.
- Equations are based on the design methodology contained in AISC Steel Design Guide 1 – Base Plate and Anchor Rod Design, second edition using a rectangular compression stress block.

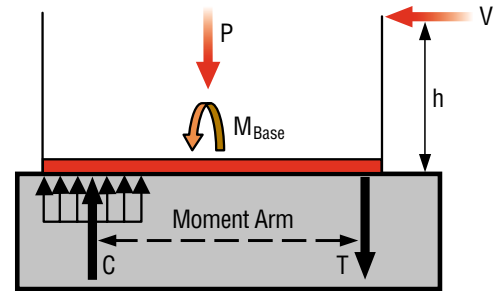
**Forces at Base of Wall**

T = Resulting anchorage tension (uplift) force (kips)

V = Design shear (kips)

P = Total vertical load (kips)

h = Wall height (inches)

For two-story stacked applications, substitute M_{base} for Vh :

$$Vh = M_{base} \left(\frac{12}{1000} \right) \text{ kip-in}$$

Where M_{base} = Design moment at base of wall (ft-lbs)

EXAMPLE 1 – Single-Story S/SSW:

Given:

- S/SSW18x9X wall on 2.5 ksi concrete
- 2006 International Building Code®, Seismic
- Design Shear (V) = 1.5 kips < 1.835 kips ($V_{allowable}$)
- P (Vertical Load) = 1.0 kip
- h = Wall height = 109"

$$T = \left[45.0 - \sqrt{2025 - 5.95 (6.1P + Vh)} \right] - P$$

$$T = \left[45.0 - \sqrt{2025 - 5.95 (6.1 \times 1 + 1.5 \times 109)} \right] - 1.0 = \underline{\underline{12.1 \text{ kips}}}$$

EXAMPLE 2 – Two-Story Stacked S/SSW Condition:

Given:

- See Two-Story Design Example on page 49
- S/SSW18x9X-STK wall on 2.5 ksi concrete
- 2006 International Building Code®, Wind
- M_{base} = 17,550 ft-lbs. (Moment at base of two-story stacked wall)
- $Vh = 17,550 \times \left(\frac{12}{1000} \right) \text{ kip-in} = 210.6 \text{ kip-in}$
- P (Vertical Load) = 2.0 kips

$$T = \left[45.0 - \sqrt{2025 - 5.95 (6.1P + Vh)} \right] - P$$

$$T = \left[45.0 - \sqrt{2025 - 5.95 (6.1 \times 2 + 210.6)} \right] - 2 = \underline{\underline{16.6 \text{ kips}}}$$

STEEL STRONG-WALL®: Cold-Formed Steel 1st-Story Floor Systems



Steel Strong-Wall® panels designed for use on concrete foundations can now be used with cold-formed steel floor systems by extending the anchor bolts and installing compression nuts and stud blocking below the wall.

MATERIAL & FINISH: See page 40.

For product data and naming scheme information, see page 40.

CFS First-Floor Wall Connection Kit

Wall Width (in)	Model No.	Contents
12	SSW12-1KT	(1) Shear-Transfer Plate (with #14 self-drilling screws)
15	SSW15-1KT	(2) ¾" or 1"x18" Threaded Rods F1554 Grade 36
18	SSW18-1KT	(2) Coupler Nuts
21	SSW21-1KT	(2) Heavy Hex Nuts
24	SSW24-1KT	Installation Instructions

1. Two heavy hex nuts included with each wall.

Lateral Systems

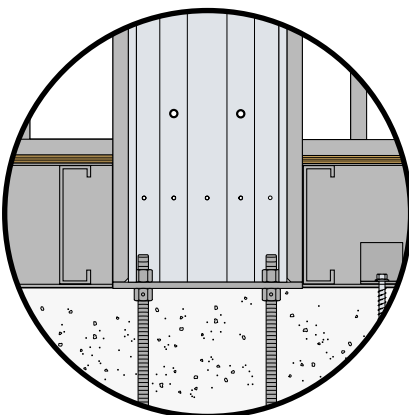
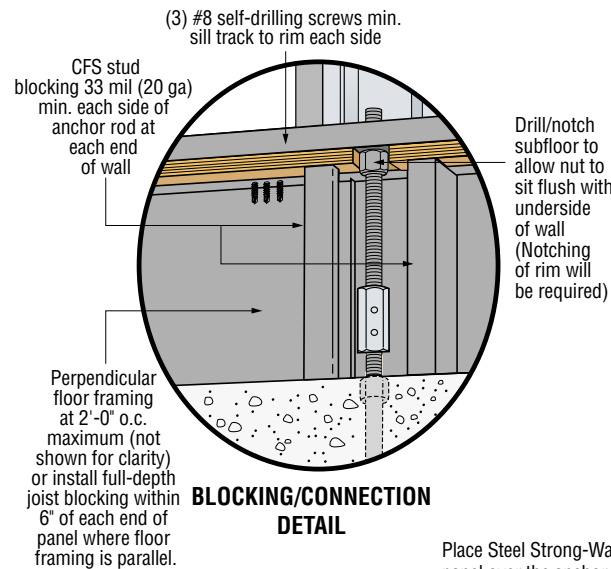

Place Steel Strong-Wall® panel over the anchor bolts and secure with heavy hex nuts (provided). Snug tight fit required, do not use an impact wrench.

- 1¼" wrench/socket required for ¾" nut
- 1½" wrench/socket required for 1" nut

CNW Nuts and Threaded Rods (Included with SSW_-1KT)

Shear transfer by Designer



For a complete set of wall profile drawings, see page 40.



DO NOT cut wall or enlarge existing holes

Shear-Transfer Plate Fasteners for Raised-Floor Applications

Strong-Wall Width	Fastener #14 Screws	Quantity #10 Screws
12" Wall	4	6
15" Wall	4	10
18" Wall	6	12
21" Wall	6	16
24" Wall	7	18

SSW Shear-Transfer Plate installs with #10 self-drilling screws (Quik Drive TRSD34S1016 recommended, not provided) into the rim and #14 self-drilling screws into the Strong-Wall® (included with SSW_-1KT)

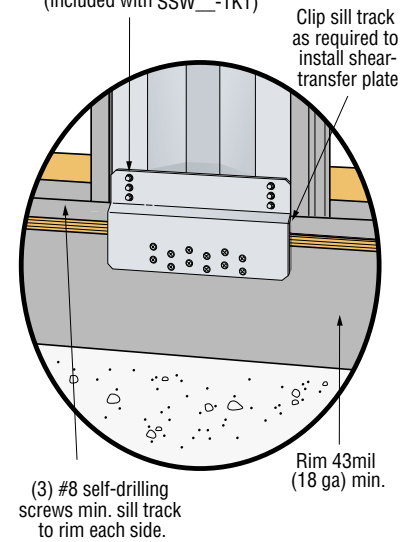

(3) #8 self-drilling screws min. sill track to rim each side

Foundation Design (size and reinforcement) by Designer

SSWAB

STEEL STRONG-WALL®: Cold-Formed Steel 1st-Story Floor Systems
2006 International Building Code®

S/SSW Model	Seismic ²			Wind		
	Allowable ASD Shear Load V (lbs)	Drift at Allowable Shear (in)	Uplift at Allowable Shear ⁴ (lbs)	Allowable ASD Shear Load V (lbs)	Drift at Allowable Shear (in)	Uplift at Allowable Shear ⁴ (lbs)
S/SSW12x7	530	0.31	6165	530	0.31	6165
S/SSW15x7	1355	0.35	11720	1395	0.36	12065
S/SSW18x7	1850	0.27	12080	1850	0.27	12080
S/SSW21x7	2100	0.20	11015	2100	0.20	11015
S/SSW24x7	2450	0.17	10740	2450	0.17	10740
S/SSW12x8X	435	0.40	6135	435	0.40	6135
S/SSW15x8X	1050	0.42	11010	1150	0.46	12060
S/SSW18x8X	1525	0.36	12075	1525	0.36	12075
S/SSW21x8X	1900	0.29	12085	1900	0.29	12085
S/SSW24x8X	2270	0.24	12065	2270	0.24	12065
S/SSW12x9X	390	0.47	6185	390	0.47	6185
S/SSW15x9X	900	0.48	10605	1025	0.54	12080
S/SSW18x9X	1355	0.42	12055	1355	0.42	12055
S/SSW21x9X	1690	0.34	12080	1690	0.34	12080
S/SSW24x9X	2020	0.28	12065	2020	0.28	12065
S/SSW15x10X	785	0.53	10270	925	0.63	12100
S/SSW18x10X	1220	0.48	12050	1220	0.48	12050
S/SSW21x10X	1520	0.39	12060	1520	0.39	12060
S/SSW24x10X	1820	0.32	12065	1820	0.32	12065

1. Loads are applicable to 1st-Story Cold-Formed Steel Raised-Floor installations supported on concrete or masonry foundations using the ASD basic (Section 1605.3.1) or the alternative basic (Section 1605.3.2) load combinations. Load values include evaluation of anchor rod compression capacity and do not require further evaluation by the Designer.
2. For seismic designs based on the 2006 IBC using R = 6.5. For other codes, use the seismic coefficients corresponding to light-frame bearing walls with wood structural panels or sheet steel panels.
3. Minimum standard-strength anchor bolts required. See pages 50–54 for SSWAB anchor bolt information and anchorage solutions.
4. Tabulated anchor tension (uplift) loads assume no resisting axial load. Anchor rod tension at design shear load and including the effect of axial load may be determined using the Strong-Wall Selector™ software or the following equation:

$$T = [(V \times h) / B] - P/2$$
 where: T = Anchor rod tension load (lbs)
 V = design shear load (lbs)
 h = Strong-Wall® height per page 40 (in)
 P = applied axial load (lbs)
 B = Anchor bolt centerline dimension (in)
 (6⁵/₁₆" for SSW12, 9¹/₄" for SSW15, 12¹/₄" for SSW18,
 15¹/₄" for SSW21, and 18¹/₄" for SSW24)
5. Allowable shear loads assume a maximum first-floor joist depth of 12".
6. Allowable shear loads are based on 1000 lbs. total uniformly distributed axial load acting on the entire panel in combination with the shear load. For allowable shear loads at 2000 lbs. uniformly distributed axial load, multiply table values by 0.92 for SSW12x models, and 0.96 for other SSW widths.
7. Top-of-wall screws for the S/SSW shall be approved 1/4" or #14 self-drilling screws with a minimum nominal shear strength (P_{SS}) of 2000 lbs. Top of panel shall be connected to a minimum 43 mil (18 ga) thick steel member typical.

STEEL STRONG-WALL®: Cold-Formed Steel Two-Story Stacked on Concrete Foundations



A complete stacked-wall solution for two-story applications. Now there is a Steel Strong-Wall® option for two-story cold-formed steel installations that combines simplified installation with superior performance.

- Some of the highest loads in the industry, and design procedures that account for cumulative overturning.
- Complete concrete anchorage designs for two-story applications (*foundation design by Designer*).
- No bearing plates to install. Walls can be placed flush against a corner.
- Same anchor bolt template as single-story installation.
- Compression loads transferred by nut/rod.

MATERIAL & FINISH: See page 40.

NAMING SCHEME

Top Wall:

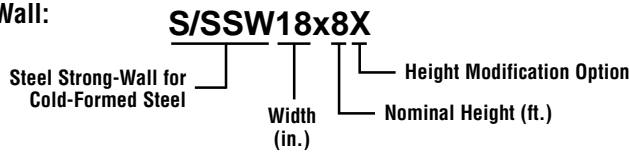

Bottom Wall:

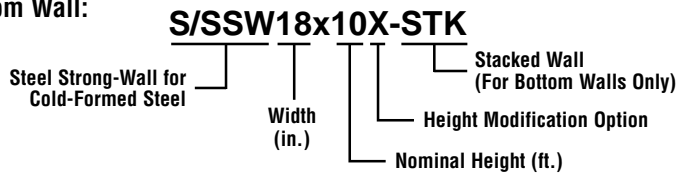

COLD-FORMED STEEL TWO-STORY STACKED-WALL PRODUCT DATA - BOTTOM WALL

Model No.	W	MAX H ¹	T	Anchor Bolts		Number of Screws in Top of Wall
	(in)	(in)	(in)	Qty.	Dia.	
S/SSW15x8X-STK	15"	97	3½"	2	1"	6
S/SSW18x8X-STK	18"	97	3½"	2	1"	9
S/SSW21x8X-STK	21"	97	3½"	2	1"	12
S/SSW24x8X-STK	24"	97	3½"	2	1"	14
S/SSW15x9X-STK	15"	109	3½"	2	1"	6
S/SSW18x9X-STK	18"	109	3½"	2	1"	9
S/SSW21x9X-STK	21"	109	3½"	2	1"	12
S/SSW24x9X-STK	24"	109	3½"	2	1"	14
S/SSW15x10X-STK	15"	121	3½"	2	1"	6
S/SSW18x10X-STK	18"	121	3½"	2	1"	9
S/SSW21x10X-STK	21"	121	3½"	2	1"	12
S/SSW24x10X-STK	24"	121	3½"	2	1"	14

1. Specify height when ordering "X-STK" models
2. See page 40 for product data on top wall.

Two-Story Stacked-Wall Connection Kit

Wall Width (in)	Model No.	Contents
15	SSW15-2KT	(1) Shear-Transfer Plate (with #14 self-drilling screws, included) (2) 1"x48" Threaded Rods F1554 Grade 36 (6) Heavy Hex Nuts Installation Instructions
18	SSW18-2KT	
21	SSW21-2KT	
24	SSW24-2KT	

1. Two heavy hex nuts included with each wall.



For a complete set of wall profile drawings, see page 40.

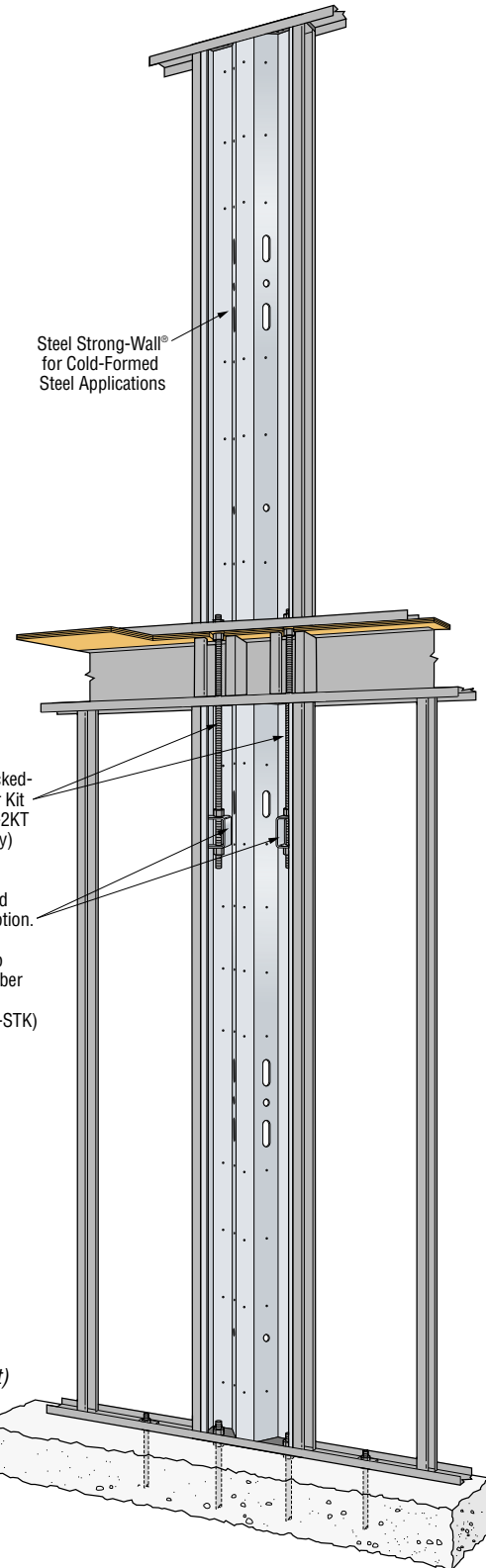

STEEL STRONG-WALL®: Two-Story Stacked on Concrete Foundations

INSTALLATION

- Do not cut the Steel Strong-Wall® or enlarge existing holes. Doing so will compromise the performance of the wall.
- Do not use an impact wrench to tighten nuts on the anchor bolts.
- Drill or notch the subfloor to allow the compression nut to sit flush with the underside of the 2nd-story wall (notching of the rim will be required).

Shear-Transfer Plate Fasteners

Strong-Wall Width	Fastener Quantity	
	#14 Screws	#10 Screws
12" Wall	4	6
15" Wall	4	10
18" Wall	6	12
21" Wall	6	16
24" Wall	7	18

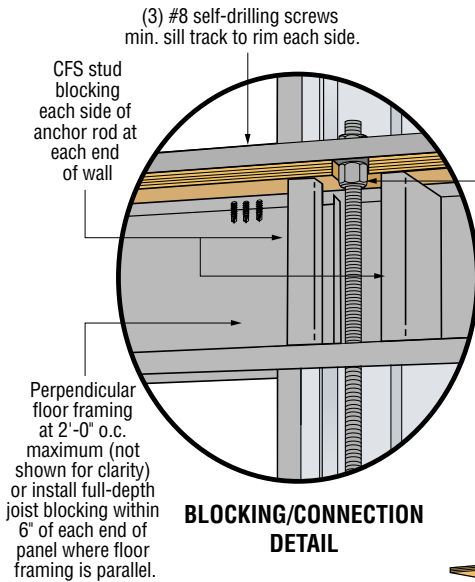

Attach to top track with 1/4" or #14 self-drilling screws (not provided)

Drill/notch subfloor to allow nut to sit flush with underside of wall. (Notching of rim will be required)

Clip sill track as required to install shear-transfer plate

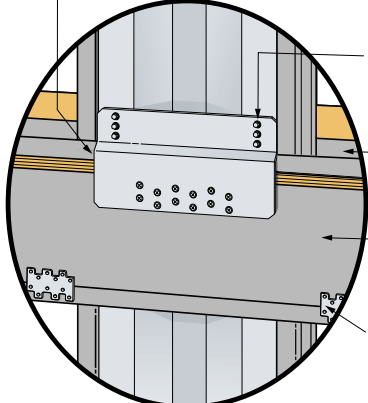

SSW Shear-Transfer Plate installs with #10 self-drilling screws installed into rim (Quik Drive TRSD34S1016 recommended, not provided) and #14 self-drilling screws into the Strong-Wall® (included with SSW_-2KT)

EXTERIOR VIEW OF SHEAR-TRANSFER PLATE

Use SSW_-2KT connection kit to attach standard wall above to "X-STK" model below

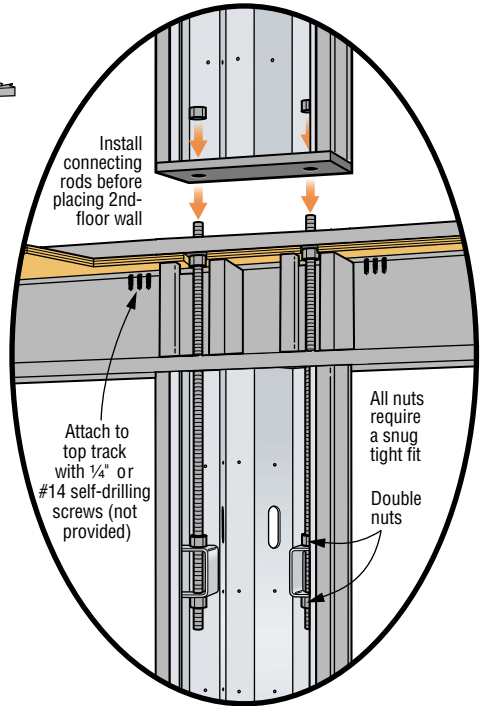

TWO-STORY STACKED-WALL CONNECTION DETAIL

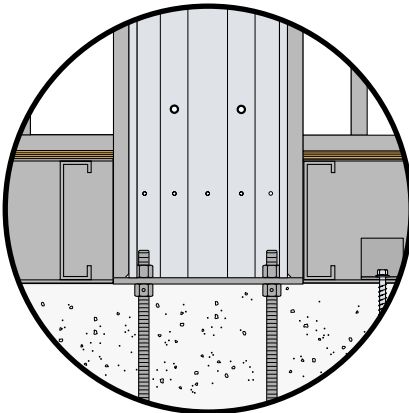

ALTERNATE 1ST-FLOOR INSTALLATION

Specify taller wall model to allow for floor framing and use load values for installation on concrete pages 41.

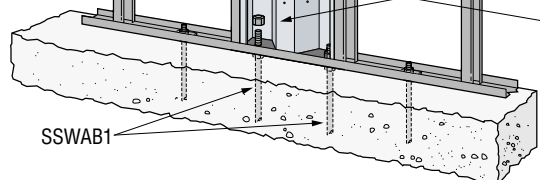

Place Steel Strong-Wall® panel over the anchor bolts and secure with heavy hex nuts (provided). Snug tight fit required. Do not use an impact wrench.

- 1 5/8" wrench/socket required for 1" nut.

STEEL STRONG-WALL®: Cold-Formed Steel Two-Story Stacked on Concrete Foundations**Second-Story Walls^{6, 8} – 2006 International Building Code**

Second-Story Wall Models	Seismic ²		Wind	
	Allowable ASD Shear Load V (lbs)	Drift at Allowable Shear (in)	Allowable ASD Shear Load V (lbs)	Drift at Allowable Shear (in)
S/SSW15x7	600	0.21	600	0.21
S/SSW18x7	1080	0.21	1390	0.27
S/SSW21x7	1650	0.21	1815	0.23
S/SSW24x7	2295	0.21	2330	0.21
S/SSW15x8X	550	0.29	550	0.29
S/SSW18x8X	995	0.31	1275	0.39
S/SSW21x8X	1515	0.30	1650	0.33
S/SSW24x8X	1970	0.27	1970	0.27
S/SSW15x9X	510	0.35	510	0.35
S/SSW18x9X	940	0.38	1180	0.47
S/SSW21x9X	1435	0.37	1465	0.38
S/SSW24x9X	1755	0.31	1755	0.31
S/SSW15x10X	475	0.41	475	0.41
S/SSW18x10X	890	0.45	1060	0.54
S/SSW21x10X	1300	0.42	1300	0.42
S/SSW24x10X	1580	0.36	1580	0.36

- Allowable base moment and anchor uplifts are applicable to installation on concrete foundations with minimum $f'c = 2,500$ psi using the ASD basic (Section 1605.3.1) or the alternative basic (Section 1605.3.2) load combinations. Load values include evaluation of anchor rod compression at second story and bearing stresses at foundation.
- For seismic designs based on the 2006 IBC using $R = 6.5$. For other codes, use the seismic coefficients corresponding to light-frame bearing walls with wood structural panels or sheet steel panels.
- Two-Story Stacked-Wall installations may consist of any height combination of equal width wall models listed in these tables.
- Loads are based on a 1000 lbs. maximum uniformly distributed total axial load acting on the second-story panel and a 2000 lbs. maximum uniformly distributed total axial load acting on the first-story panel in combination with the tabulated shear load and base moment.
- The designer must verify that the cumulative overturning moment at the base of the first-story Steel Strong-Wall does not exceed the allowable base moment capacity. See design example on page 49 for procedure.
- The allowable second-story shear loads assume a maximum floor joist depth of 14".
- Allowable shear, drift, and base moment values may be interpolated for intermediate heights.
- Minimum ASTM F 1554 Grade 36 threaded rods are required at the second-story wall anchorage.
- High-strength anchor bolts are required at the first-story wall for anchor tension (uplift) forces exceeding the allowable load for standard strength bolts tabulated on pages 50–51. See pages 50–54 for SSWAB anchor bolt information and anchorage solutions.
- Tabulated anchor tension (uplift) loads assume no resisting axial load. For anchor tension loads at design shear values and including the effect of axial load, refer to the Strong-Wall Selector software or use the equations on page 43. Drifts at lower design shear or base moment may be linearly reduced.
- Top-of-wall screws for the S/SSW shall be approved ¼" or #14 self-drilling screws with a minimum nominal shear strength (P_{ss}) of 2000 lbs. Top of panel shall be connected to a minimum 43 mil (18 ga) thick steel member typical. First-Story S/SSW 24x8X-STK requires connection to a minimum 54 mil (16 ga) thick steel member where the total applied shear load exceeds 4230 lbs.

FIRST-STORY WALLS ON CONCRETE FOUNDATIONS^{5, 9, 11} – 2006 INTERNATIONAL BUILDING CODE

First-Story Wall Models	Seismic ²			Wind		
	Allowable ASD Base Moment (ft-lbs)	Drift at Allowable Base Moment (in)	Uplift at Allowable Base Moment ¹⁰ (lbs)	Allowable ASD Base Moment (ft-lbs)	Drift at Allowable Base Moment (in)	Uplift at Allowable Base Moment ¹⁰ (lbs)
S/SSW15x8X-STK	10130	0.41	12065	10130	0.41	12065
S/SSW18x8X-STK	17300	0.41	16895	22230	0.53	24075
S/SSW21x8X-STK	26390	0.41	21905	31000	0.48	27545
S/SSW24x8X-STK	36700	0.39	26335	40040	0.43	29770
S/SSW15x9X-STK	9705	0.47	11440	9945	0.48	11790
S/SSW18x9X-STK	16670	0.47	16110	21480	0.61	22835
S/SSW21x9X-STK	25435	0.46	20855	28990	0.53	24950
S/SSW24x9X-STK	36210	0.45	25860	37515	0.47	27145
S/SSW15x10X-STK	9160	0.51	10665	9460	0.53	11090
S/SSW18x10X-STK	16185	0.53	15515	20335	0.66	21060
S/SSW21x10X-STK	24485	0.52	19845	25895	0.55	21355
S/SSW24x10X-STK	33645	0.49	23460	33645	0.49	23460

STEEL STRONG-WALL®: Cold-Formed Steel Two-Story Stacked on Concrete Foundations

STEEL STRONG-WALL® TWO-STORY DESIGN EXAMPLE

Example: Cold-Formed Steel Two-Story Wall Design

Given:

2006 IBC, Wind, $f'_c = 2500$ psi

$V_{2\text{nd-story wall}} = 650$ lbs.

$V_{1\text{st-story wall}} = 650$ lbs.

$V_{\text{total}} = 650 \text{ lbs.} + 650 \text{ lbs.} = 1,300$ lbs.

M_{allow} = Allowable ASD Base Moment (ft-lbs.)
(See *Cold-Formed Steel Two-Story Stacked Tables*)

V_{allow} = Allowable ASD Shear Load V (lbs.)
(See *Cold-Formed Steel Two-Story Stacked Tables*)

STEP 1 – Select First-Story Wall (See tables on page 48)

$M_{\text{base}} = (650 \text{ lbs.} \times 18 \text{ ft.}) + (650 \text{ lbs.} \times 9 \text{ ft.}) = 17,550$ ft-lbs.

Using First-Story Wall Table, select a 9-foot wall with $M_{\text{allow}} \geq M_{\text{base}}$

Select S/SSW18x9X-STK

$M_{\text{allow}} = 21,480$ ft-lbs. > 17,550 ft-lbs. **OK**

STEP 2 – Check Second-Story Wall

Using the Second-Story Wall Table on page 48, check the capacity of an 8-foot wall with the same width as the First-Story Wall selected in Step 1:

Select S/SSW18x8X

$V_{\text{allow}} = 1,275$ lbs. > 650 lbs. **OK**

>>> Use S/SSW18x8X over S/SSW18x9X-STK

Specify height when ordering “X” and “X-STK” models

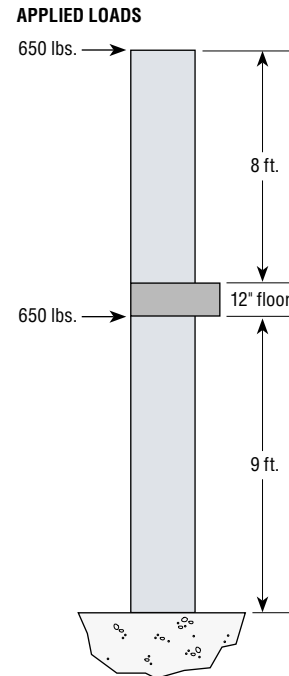

STEEL STRONG-WALL®: Anchorage Solutions



Lateral Systems

SSWAB ANCHOR BOLTS

SSWAB anchor bolts in 3/4" and 1" diameters offer flexibility to meet specific project demands. Inspection is easy; the head is stamped with a "No Equal" symbol for identification, bolt length, bolt diameter, and optional "HS" for High Strength if specified.

MATERIAL: ASTM F1554 Grade 36; High-Strength (HS) ASTM A449

An additional nut for template installation is provided with each SSWAB. It may also be used for SSW installation.

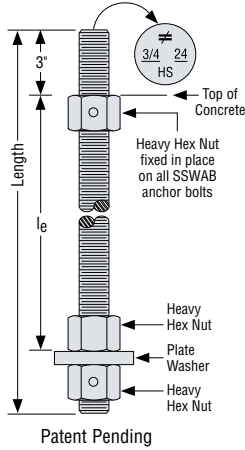

SSWHSR EXTENSION KIT

SSWHSR allows for anchorage in tall stemwall applications where full embedment of an SSWAB into the footing is required. The head is stamped for identification like an SSWAB. Kit includes ASTM A449 high-strength rod with heavy hex nut fixed in place and high-strength coupler nut. Do not use in place of SSWAB.

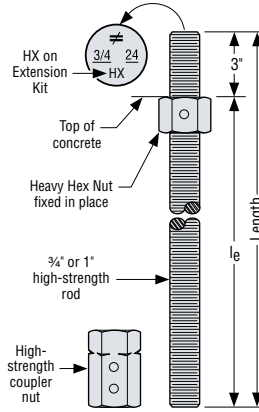

SSWHSR_KT
Patent Pending

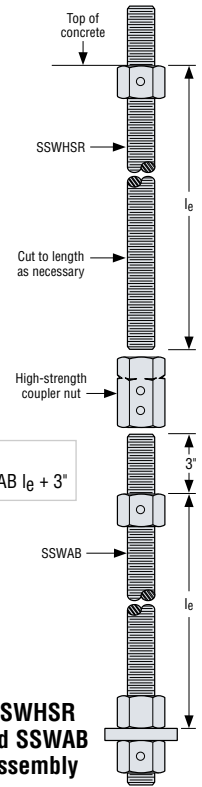

Steel Strong-Wall Width (in)	Model No.	Dia. (in)	Total Length (in)	le (in)
12" Model	SSWAB3/4x24	3/4	24	19
	SSWAB3/4x24HS	3/4	24	19
	SSWAB3/4x30	3/4	30	25
	SSWAB3/4x30HS	3/4	30	25
	SSWAB3/4x36HS	3/4	36	31
15", 18", 21", 24" Models	SSWAB1x24	1	24	19
	SSWAB1x24HS	1	24	19
	SSWAB1x30	1	30	25
	SSWAB1x30HS	1	30	25
	SSWAB1x36HS	1	36	31

Steel Strong-Wall Width (in)	Model No.	Dia. (in)	Total Length (in)	le (in)
12" Model	SSWHSR3/4x2KT	3/4	24	21
	SSWHSR3/4x3KT	3/4	36	33
15", 18", 21", 24" Models	SSWHSR1x2KT	1	24	21
	SSWHSR1x3KT	1	36	33

STEEL STRONG-WALL® ANCHORAGE SOLUTIONS – 2500 psi CONCRETE

Design Criteria	Concrete Condition	Anchor Strength	SSWAB 3/4" ANCHOR BOLT			SSWAB 1" ANCHOR BOLT		
			ASD Allowable Uplift (lbs)	W (in)	de (in)	ASD Allowable Uplift (lbs)	W (in)	de (in)
Seismic	Cracked	Standard	9600	25	9	17100	36	12
		High Strength	19900	39	13	35300	56	19
	Uncracked	Standard	9600	21	7	17100	32	11
		High Strength	19900	34	12	35300	49	17
Wind	Cracked	Standard	4500	12	6	5600	14	6
			6900	16	6	12700	24	8
			9600	20	7	17100	30	10
			11100	22	8	22400	35	12
		High Strength	13500	25	9	26800	39	13
			16000	28	10	31600	43	15
			19900	33	11	35300	47	16
			5600	12	6	5600	12	6
	Uncracked	Standard	7800	15	6	12000	20	7
			9600	18	6	17100	26	9
			11200	19	7	22100	30	10
			13900	22	8	26700	34	12
		High Strength	15800	24	8	32100	38	13
			19900	29	10	35300	41	14

- See pages 53–54 for foundation illustrations showing W and de dimensions.
- Anchorage designs conform to ACI 318 Appendix D with no supplementary reinforcement and cracked or uncracked concrete as noted.
- Anchor strength indicates required grade of SSWAB anchor bolt. Standard or High-Strength (HS).
- Seismic indicates Seismic Design Category C through F. Detached 1 and 2 family dwellings in SDC C may use wind anchorage solutions. Seismic anchorage designs conform to ACI 318-05 Section D.3.3.4.
- Wind includes Seismic Design Category A and B.
- Foundation dimensions are for anchorage only. Foundation design (size and reinforcement) by Designer. The registered design professional may specify alternate embedment, footing size or anchor bolt.

STEEL STRONG-WALL®: Anchorage Solutions**STEEL STRONG-WALL® ANCHORAGE SOLUTIONS – 3500 psi CONCRETE**

Design Criteria	Concrete Condition	Anchor Strength	SSWAB ¾" ANCHOR BOLT			SSWAB 1" ANCHOR BOLT		
			ASD Allowable Uplift (lbs)	W (in)	d _e (in)	ASD Allowable Uplift (lbs)	W (in)	d _e (in)
Seismic	Cracked	Standard	9600	22	8	17100	33	11
		High Strength	19900	36	12	35300	51	17
	Uncracked	Standard	9600	19	7	17100	28	10
		High Strength	19900	31	11	35300	44	15
Wind	Cracked	Standard	5300	12	6	6000	13	6
			7400	15	6	13200	22	8
			9600	18	6	17100	27	9
		High Strength	11400	20	7	23100	32	11
			14100	23	8	27800	36	12
			15900	25	9	31700	39	13
	Uncracked	Standard	6600	12	6	6600	12	6
			8300	14	6	12200	18	6
			9600	16	6	17100	23	8
		High Strength	11200	17	6	22400	27	9
			14300	20	7	27500	31	11
			16400	22	8	33100	35	12
19900	26	9	35300	37	13			

- See pages 53–54 for foundation illustrations showing W and d_e dimensions.
- Anchorage designs conform to ACI 318 Appendix D with no supplementary reinforcement and cracked or uncracked concrete as noted.
- Anchor strength indicates required grade of SSWAB anchor bolt. Standard or High Strength (HS).
- Seismic indicates Seismic Design Category C through F. Detached 1 and 2 family dwellings in SDC C may use wind anchorage solutions. Seismic anchorage designs conform to ACI 318-05 Section D.3.3.4.
- Wind includes Seismic Design Category A and B.
- Foundation dimensions are for anchorage only. Foundation design (*size and reinforcement*) by Designer. The registered design professional may specify alternate embedment, footing size or anchor bolt.

STEEL STRONG-WALL® ANCHORAGE SOLUTIONS – 4500 psi CONCRETE

Design Criteria	Concrete Condition	Anchor Strength	SSWAB ¾" ANCHOR BOLT			SSWAB 1" ANCHOR BOLT		
			ASD Allowable Uplift (lbs)	W (in)	d _e (in)	ASD Allowable Uplift (lbs)	W (in)	d _e (in)
Seismic	Cracked	Standard	9600	20	7	17100	30	10
		High Strength	19900	33	11	35300	47	16
	Uncracked	Standard	9600	18	6	17100	26	9
		High Strength	19900	28	10	35300	41	14
Wind	Cracked	Standard	6000	12	6	6000	12	6
			7600	14	6	12900	20	7
			9600	17	6	17100	25	9
		High Strength	11000	18	6	22600	29	10
			13900	21	7	27400	33	11
			17000	24	8	31500	36	12
	Uncracked	Standard	19900	27	9	35300	40	14
			7500	12	6	7500	12	6
			8500	13	6	12700	17	6
		High Strength	9600	15	6	17100	22	8
			10500	15	6	22600	25	9
			13800	18	6	26800	28	10
16200	20	7	32700	32	11			
19900	24	8	35300	35	12			

- See pages 53–54 for foundation illustrations showing W and d_e dimensions.
- Anchorage designs conform to ACI 318 Appendix D with no supplementary reinforcement and cracked or uncracked concrete as noted.
- Anchor strength indicates required grade of SSWAB anchor bolt. Standard or High Strength (HS).
- Seismic indicates Seismic Design Category C through F. Detached 1 and 2 family dwellings in SDC C may use wind anchorage solutions. Seismic anchorage designs conform to ACI 318-05 Section D.3.3.4.
- Wind includes Seismic Design Category A and B.
- Foundation dimensions are for anchorage only. Foundation design (*size and reinforcement*) by Designer. The registered design professional may specify alternate embedment, footing size or anchor bolt.

STEEL STRONG-WALL®: Anchorage Solutions

Lateral Systems

STEEL STRONG-WALL® SHEAR ANCHORAGE

Foundation shear reinforcement to resist shear forces from Strong-Wall® panels located at the edge of concrete is shown in the table below. The SSW12 and SSW15 used in wind applications do not require shear reinforcement when the panel design shear force is less than the anchorage allowable shear load shown in the table below.

Model	Lt or Lh (in)	SEISMIC ³		WIND ⁴					
		Shear Reinforcement	Minimum Curb/Stemwall Width (in)	Shear Reinforcement	Minimum Curb/Stemwall Width (in)	ASD Allowable Shear Load V ⁶ (lbs)			
						6" Minimum Curb/Stemwall		8" Minimum Curb/Stemwall	
						Uncracked	Cracked	Uncracked	Cracked
SSW12	9	(1) #3 Tie	6	None required	—	1370	980	1605	1145
SSW15	12	(1) #3 Tie	6	None required	—	1765	1260	2015	1440
SSW18	14	(1) #3 Hairpin	8 ⁵	(1) #3 Hairpin	6	Hairpin reinforcement achieves maximum allowable shear load of the Steel Strong-Wall® panel.			
SSW21	15	(1) #3 Hairpin	8 ⁵	(1) #3 Hairpin	6				
SSW24	17	(2) #3 Hairpins	8 ⁵	(2) #3 Hairpins	6				

1. Shear anchorage designs conform to ACI 318-05 and assume minimum $f'_c = 2500$ psi concrete. See pages 50–51 for tension anchorage.
2. Shear reinforcement is not required for panels installed on a cold-formed steel floor, interior foundation applications (panel installed away from edge of concrete), or braced-wall panel applications.
3. Seismic indicates Seismic Design Category C through F. Detached 1 and 2 family dwellings in SDC C may use wind anchorage solutions. Seismic shear reinforcement designs conform to ACI 318-05 Section D.3.3.4.
4. Wind includes Seismic Design Category A and B.
5. Where noted minimum curb/stemwall width is 6" when standard-strength SSWAB is used.
6. Use (1) #3 tie for SSW12 and SSW15 when the Steel Strong-Wall® panel design shear force exceeds the tabulated anchorage allowable shear load.
7. The registered design professional may specify alternate shear anchorage.

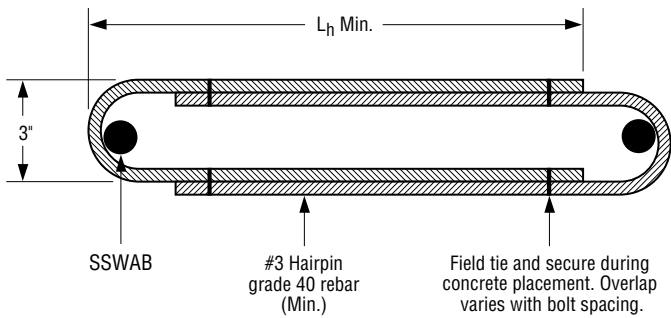

Hairpin Shear Reinforcement

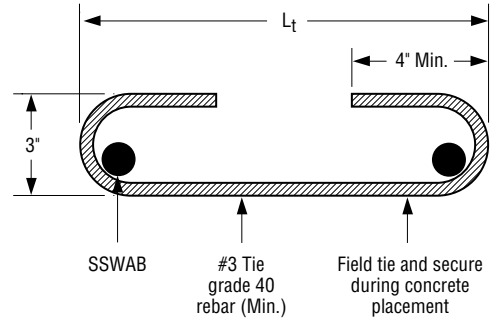

Tie Shear Reinforcement

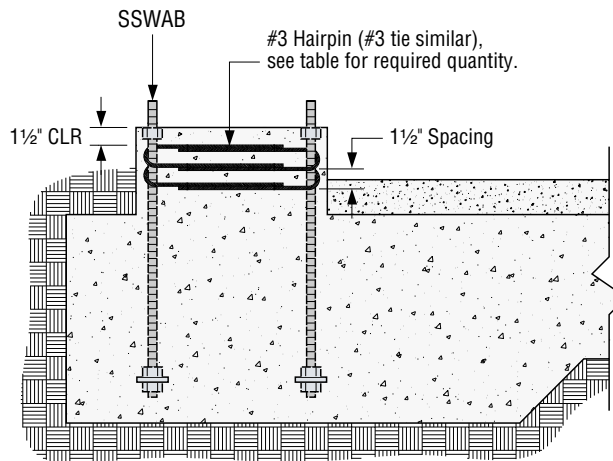

Hairpin Installation
(Garage curb shown, other footing types similar)

STEEL STRONG-WALL®: Anchorage Solutions

CURB OR STEMWALL INSTALLATION

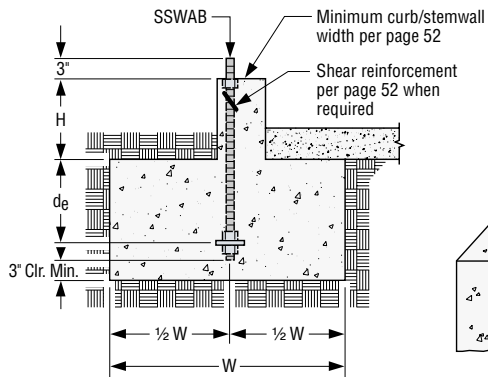

Curb or Stemwall Section View

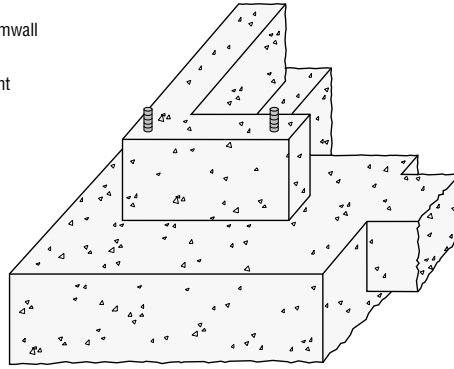

Perspective View
(Slab not shown for clarity)

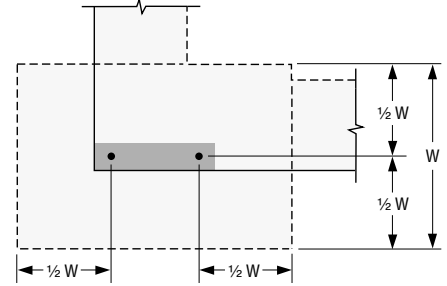

Footing Plan

SLAB-ON-GRADE INSTALLATION

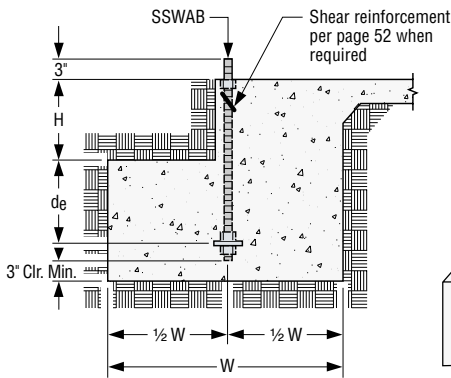

Slab-on-Grade Section View

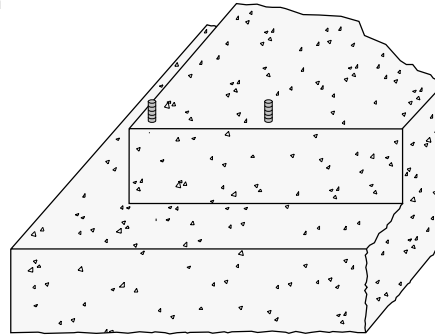

Perspective View

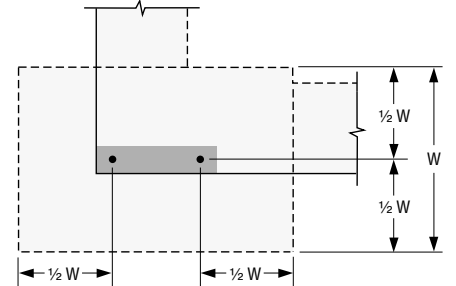

Footing Plan

BRICK LEDGE INSTALLATION

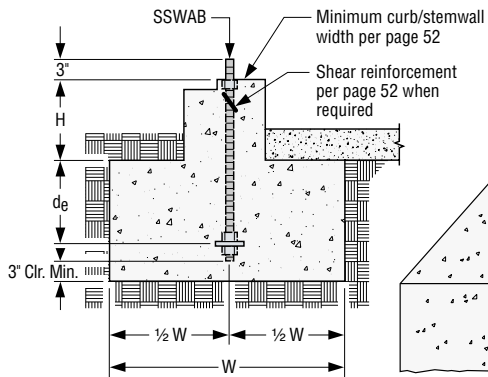

Brick Ledge Section View

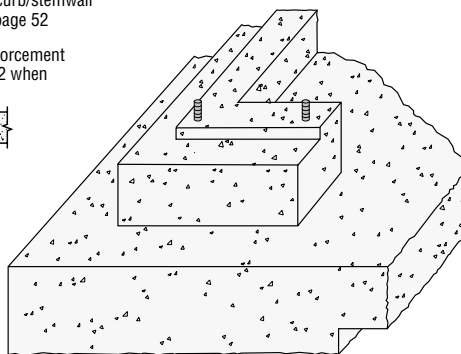

Perspective View

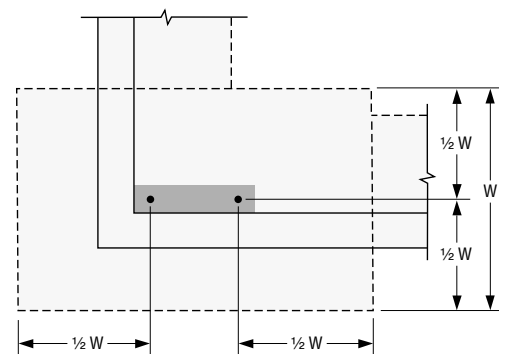

Footing Plan

Anchorage Solutions General Notes

1. The Designer may specify alternate embedment, footing size or bolt grade.
2. Footing dimensions and rebar requirements are for anchorage only.

Foundation design
(size and reinforcement) by Designer.

STEEL STRONG-WALL®: Anchorage Solutions

Lateral Systems

INTERIOR INSTALLATION

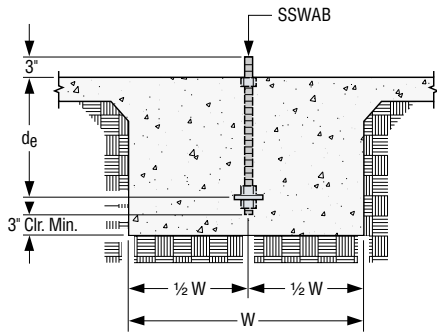

Interior Section View

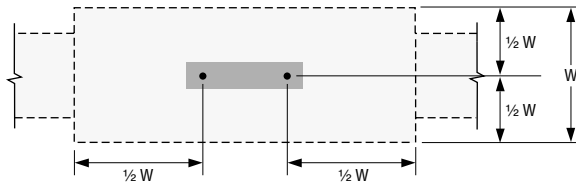

1. Footing Plan

STEMWALL EXTENSION INSTALLATION

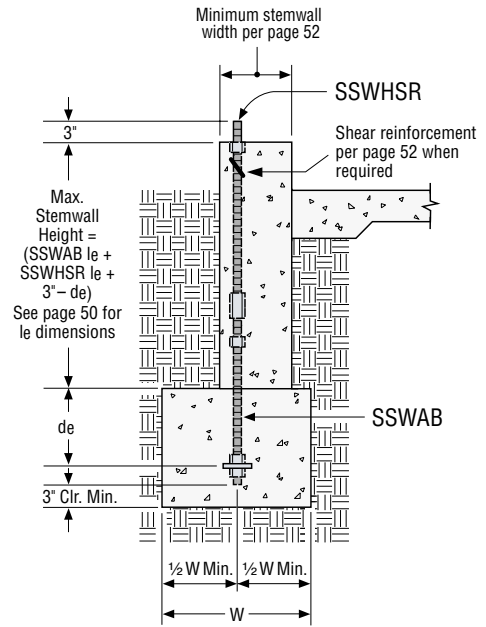

Section at Stemwall SSWAB and SSWHSR Extension Application

Anchorage Solutions General Notes

1. The Designer may specify alternate embedment, footing size or bolt grade.
2. Footing dimensions and rebar requirements are for anchorage only.

STEEL STRONG-WALL® ANCHOR BOLT LAYOUT

Wall Model	Distance From End of Wall to Center of SSWAB's (A)	Distance From Center to Center of SSWAB's (B)	Distance From Exterior Face of Wall to Center of All SSWAB's (C)
S/SSW12	2 ⁹ / ₁₆ "	6 ⁷ / ₈ "	2"
S/SSW15	2 ⁷ / ₈ "	9 ¹ / ₄ "	1 ⁷ / ₈ "
S/SSW18	2 ⁷ / ₈ "	12 ¹ / ₄ "	1 ⁷ / ₈ "
S/SSW21	2 ⁷ / ₈ "	15 ¹ / ₄ "	1 ⁷ / ₈ "
S/SSW24	2 ⁷ / ₈ "	18 ¹ / ₄ "	1 ⁷ / ₈ "

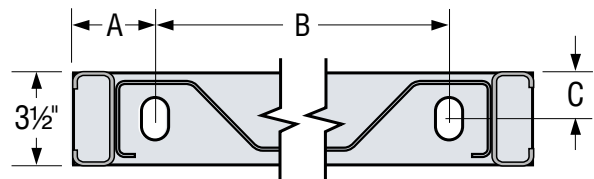

STEEL STRONG-WALL®: Anchor Bolt Templates

STEEL STRONG-WALL® ANCHOR BOLT TEMPLATES

Steel Strong-Wall Model	Width (in)	Steel Strong-Wall Template Model		
		Reversible	Panel Form	Brick Ledge
SSW12	12	SSWT12	SSWTPF12	SSWTBL12
SSW15	15	SSWT15	SSWTPF15	SSWTBL15
SSW18	18	SSWT18	SSWTPF18	SSWTBL18
SSW21	21	SSWT21	SSWTPF21	SSWTBL21
SSW24	24	SSWT24	SSWTPF24	SSWTBL24

*SSWT templates are reversible. Use the same template for interior or exterior applications. Template and nut configuration patent pending.

1. The height of the garage curb above the garage slab is critical for rough header opening at garage return walls.
2. Templates are recommended and are required in some jurisdictions.
3. Foundation by Designer.
4. Templates are the same for 4" or 6" thick walls.

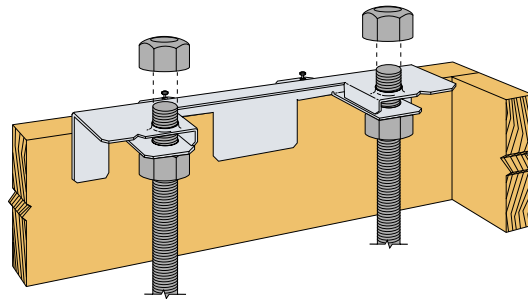
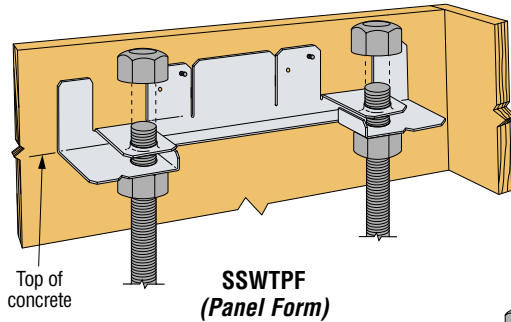

An additional nut for template installation is provided with each SSWAB. It may also be used for SSW installation.

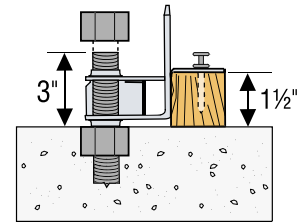
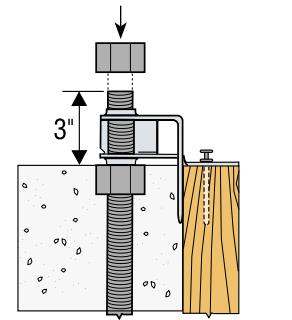

Anchor Bolt Height

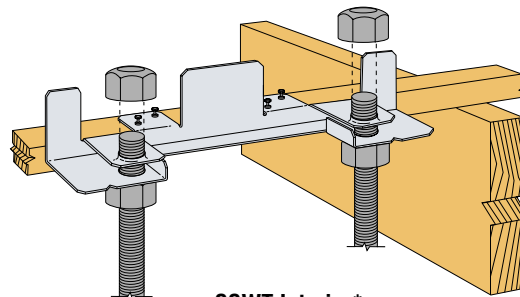
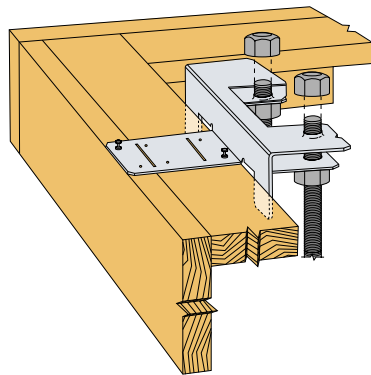

S/JCT & S/HJCT Steel Joist Hangers

New, improved, higher load-capacity joist hangers. Additional fasteners in the new S/JCT and the increased thickness of the S/HJCT increase the allowable load capacity for use with C-Joists. Joist can be attached from either side or doubled up. This hanger can be used with either steel or wood headers.

MATERIAL: S/JCT- 68 mil (14 ga); S/HJCT- 97 mil (12 ga)

FINISH: Galvanized

INSTALLATION: • Attach hanger with specified fasteners.

Use round holes for minimum load, use round and triangle holes for maximum load.

- May be used for weld-on applications. The minimum required weld to the top flange is 1/8" x 2 1/2" fillet weld to each side of top flange. Consult the code for special considerations when welding galvanized steel.

FEATURES: • Uni-directional: Joist can be attached from left or right

- One size fits joists 8" through 14" deep.
- Optional holes for additional load capacity.
- Simplicity of design.
- Quick and easy installation.
- Field skewable up to 45° left or right.

CODES: See page 8 for Code Listing Key Chart.

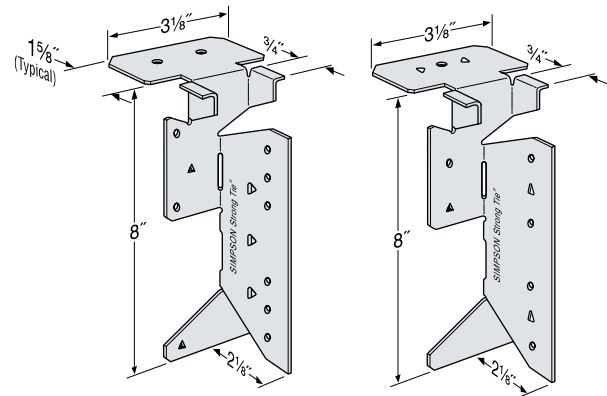

S/HJCT

U.S. Patent 6,230,467

S/JCT

Hangers

Model No.	Cold-Formed Steel Header					Code Ref.	
	Fasteners			Allowable ASD Loads ¹ 54 mil (16 ga)			
	Top	Face	Joist	Uplift	Down		
Straight Hanger							
S/JCT (min)	1-#10	2-#10	4-#10	940	1195	FC1	
S/JCT (max)	1-#10	4-#10	6-#10	1435	2105		
S/HJCT (min)	2-#10	4-#14	6-#14	1510	2920		
S/HJCT (max)	2-#10	8-#14	9-#14	1670	3855		
Skewed Hanger							
S/JCT (min)	1-#10	2-#10	4-#10	940	1135		
S/JCT (max)	1-#10	4-#10	6-#10	940	1185		
S/HJCT (min)	2-#10	4-#10	6-#14	1510	2305		
Welded Hanger⁶							
S/JCT (min)	1/8" x 2 1/2" fillet weld to each side of top flange		4-#10	-	940		
S/HJCT (min)			4-#14	-	1450		
S/HJCT Skew			4-#14	-	1235		
Attached to Masonry - Straight Hanger							
S/HJCT (min)	2-1/4" x 2-1/4" Titen	4-1/4" x 2-1/4" Titen	6-#14	710	1785	170	

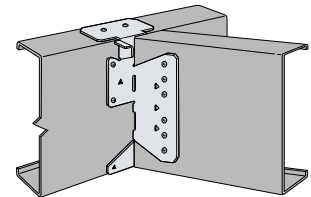

S/HJCT Skewed 45° Installation

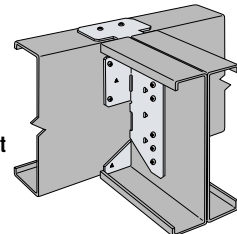

S/HJCT Double-Joist Installation

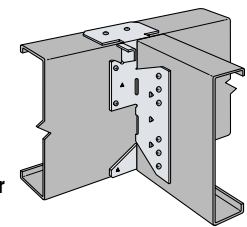

S/HJCT Installation with a CFS steel header

Model No.	Wood Header					Code Ref.	
	Fasteners			Allowable ASD Loads ²			
	Top	Face	Joist	Uplift (160)	Down (100)		
Straight Hanger							
S/JCT (min)	1-10d	2-10d	4-#10	565	945	FC1	
S/JCT (max)	1-10d	4-10d	6-#10	960	1465		
S/HJCT (min)	2-10d	4-SDS 1/4 x 3	6-#14	1210	2625		
S/HJCT (max)	2-10d	8-SDS 1/4 x 3	9-#14	1475	2980		
Skewed Hanger							
S/JCT (min)	1-10d	2-10d	4-#10	395	845		
S/JCT (max)	1-10d	4-10d	6-#10	790	1300		
S/HJCT (min)	2-10d	4-SDS 1/4 x 3	6-#14	1210	1935		

- Allowable loads for CFS headers are based on a single 54 mil (16 ga) steel.
- Allowable loads for wood headers are based on 4x10 minimum DFL, specific gravity = 0.50.
- Steel header must be braced to prevent web buckling per Designer specification.
- Steel joist shall be laterally braced per Designer specification.
- Screws shall be installed using joist hanger holes screwing through the hanger into the joist.

- Backing in the steel beam cavity is not required behind the hanger for loads listed.
- For joists with up to a 0.50" gap (short cut) use an adjustment factor of 0.87.
- For joists with a 0.50" to 0.90" gap (short cut) use an adjustment factor of 0.75.

S/HJCT Installation with a 4x10 wood header

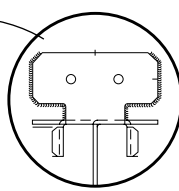
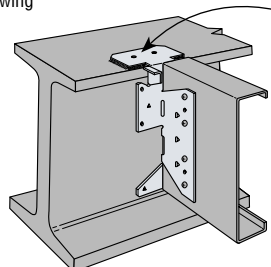
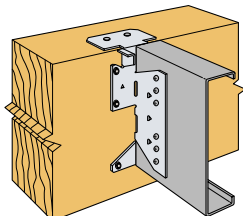

S/HJCT Weld-On Installation with an I-Beam. Install joist's fasteners as shown

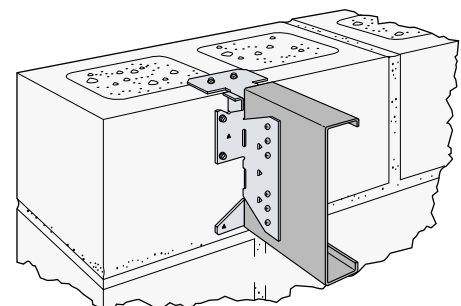

S/HJCT Installation on masonry header

S/LBV / S/B and S/BA Hangers

S/BA is the new Simpson Strong-Tie® top-flange hanger for cold-formed steel. The S/BA is a cost-effective alternative to heavier, special-order hangers. It is value engineered and tested to achieve higher allowable loads and increased performance. It may be fastened with screws or powder-actuated fasteners or welded to the header, providing more design options and greater versatility.

S/LBV and S/B hangers are manufactured with precision forming and quality control, providing dimensional accuracy and helping to ensure proper bearing area and connection.

MATERIAL: S/LBV, S/BA – 68mil (14 ga); S/B – 97mil (12 ga)

FINISH: Galvanized

INSTALLATION:

- S/LBV, S/B, and S/BA may be used for weld-on applications; a minimum of 1/8" x 2" fillet weld on each top flange is required. Distribute the weld equally on both top flanges. Consult the code for special consideration when welding galvanized steel. Uplift loads do not apply.
- S/BA may be installed using powder-actuated fasteners. PDPAT-62KP (0.157 x 1/8") powder-actuated fastener shall be installed using the appropriate level of powder load so the entire pointed portion of the fastener penetrates through the steel. A powder-actuated fastener with a "tophat" crush sleeve is recommended in case the head of the fastener is not fully flush with the connector.
- Installation of powder-actuated fasteners may vary due to, but not limited to, the type of powder-actuated tool, cleanliness of tool, type of powder load and steel.

OPTIONS: Skew only:

- S/LBV and S/B series can be skewed to a maximum of 45 degrees.

CODES: See page 8 for Code Reference Key Chart

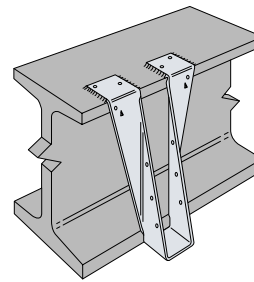
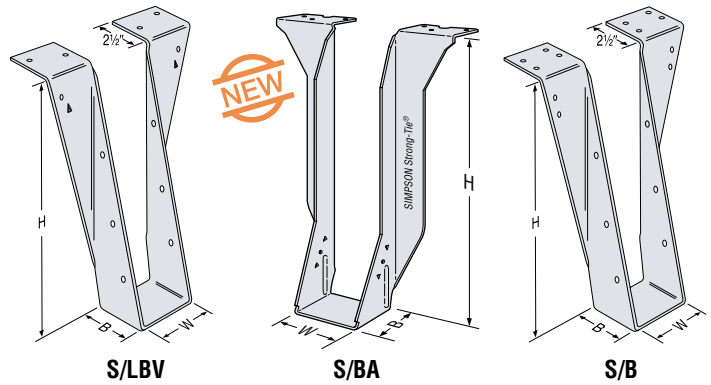

S/LBV, S/B, and S/BA are acceptable for weld-on applications (S/LBV shown)

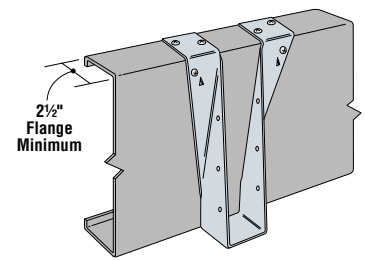

S/LBV Installation with a CFS steel header

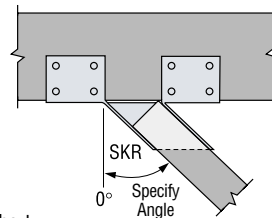

Top View S/B Hanger Skewed Right

Model	Dimensions			Fasteners			Allowable ASD Loads ⁵		Code Ref.
	W	H	B	Top	Face	Joist	Uplift	Down	
Cold-Formed Steel Header – Straight Hanger									
S/LBV	See Table	6 to 20	2 1/4	4 - #10	2 - #10	3 - #10	1010	3150	FC1
S/B		6 to 30	3	8 - #10	4 - #14	3 - #14	1855	5970	
S/BA		See Table	3	6 - #10	—	1 - #10	—	3475	160
Cold-Formed Steel Header – Skewed Hanger									
S/LBV	See Table	6 to 20	2 1/4	4 - #10	2 - #10	3 - #10	1010	2220	FC1
S/B		6 to 30	3	8 - #10	4 - #14	3 - #14	1855	4195	
Powder-Actuated Fastener or Welded to Steel Header – Straight Hanger									
S/LBV	See Table	6 to 20	2 1/4	4 - 1/8" x 2" fillet weld to each side of top flange	—	3 - #10	—	2965	FC1
S/B		6 to 30	3		—	3 - #14	—	5755	
S/BA		See Table	3	6 - 0.157" x 5/8" PAT	—	1 - #10	—	2920	160
S/BA			3		—	1 - #10	—	2685 ⁴	

- Designer shall ensure that the joist member adequately transfers load to hanger.
- Cold-formed steel / steel-beam header must be braced to prevent buckling per Designer specification.
- Powder-actuated fasteners may be installed in up to 3/8" steel headers having a minimum Fy=36,000 psi.
- Load is based on using the Simpson Strong-Tie® PDPAT-62KP powder-actuated fastener and a minimum Red (level 5) powder load.
- Tabulated loads are based on testing with full bearing of 2 1/2" flange-depth minimum with 68 mil (14 ga) CFS for S/LBV and S/BA hanger and 97 mil (12 ga) CFS for S/B hanger.

S/LBV Series Model No.	S/B Series Model No.	W
S/LBV1.56	S/B1.56	1 1/16
S/LBV1.81	S/B1.81	1 13/16
S/LBV2.06	S/B2.06	2 1/16
S/LBV2.37	S/B2.37	2 3/8
S/LBV2.56	S/B2.56	2 3/16
S/LBV2.68	S/B2.68	2 11/16
S/LBV3.12	S/B3.12	3 1/8
S/LBV3.56	S/B3.56	3 3/16
S/LBV3.62	S/B3.62	3 5/8
S/LBV4.06	S/B4.06	4 1/16
S/LBV4.12	S/B4.12	4 1/8
S/LBV4.28	S/B4.28	4 1/4
S/LBV4.75	S/B4.75	4 3/4
S/LBV5.50	S/B5.50	5 1/2

S/BA Series Model No.	W	H
S/BA2.12/8	2 1/8	8
S/BA2.12/10		10
S/BA2.12/12		12
S/BA2.12/14		14
S/BA4.18/8	4 3/16	8
S/BA4.18/10		10
S/BA4.18/12		12
S/BA4.18/14		14

W/WP Hangers



This series of purlin hangers offer the greatest design flexibility and versatility.

MATERIAL: Stirrup—97 mil (12 ga)
FINISH: Simpson Strong-Tie gray paint. Some models available hot-dip galvanized; specify HDG, see Corrosion Information on page 12–13.

INSTALLATION: Hangers may be welded to steel headers with 1/8" for W and 3/16" for WP by 1 1/2" fillet welds located at each end of the top flange.

OPTIONS: • W and H dimensions are modifiable.

SLOPED AND/OR SKEWED SEAT

- W/WP series may be skewed to a maximum of 84° and/or sloped to a maximum of 45°.
- For slope only, skew only, or slope and skew combinations, the allowable load is 100% of the table load.
- Specify the slope up or down in degrees from the horizontal plane and/or the skew right or left in degrees from the perpendicular vertical plane. Specify whether low side, high side or center of joist will be flush with the top of the header.

CODE: See page 8 for Code Listing Key Chart.

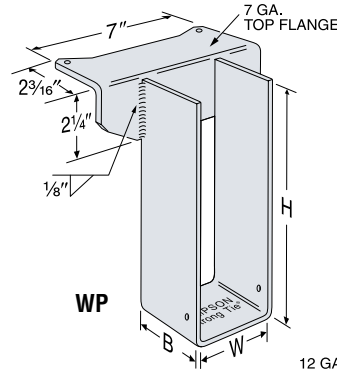

Some model configurations may differ from those shown. Call Simpson Strong-Tie for details.

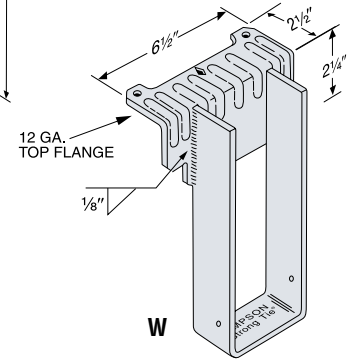

Hangers

Model No.	Dimensions			Fasteners		Allowable Down Loads	Code Ref.
	W	H	B	Header	Joist		
W	1 1/2 - 4	4° - 30	2 1/2 - 5	Weld	1 - #10	2335	170
WP	1 9/16 - 7 1/2	4° - 30	2 1/2 - 5	Weld	1 - #10	3650	

1. For hanger heights exceeding the joist height the allowable load is 0.50 of the table value.
2. The Designer shall ensure that the joist member adequately transfers load to the hanger.
3. Not all combinations of W, H, and B dimensions are available. Contact Simpson Strong-Tie.

HUC Hangers

MATERIAL: 68 mil (14 ga)

FINISH: Galvanized

INSTALLATION:

- HUC series hangers may be welded to supporting structural steel members.
- Use 1" weld segments equally spaced top and bottom, with half the segments on each side of hanger.
- Welds may be either Lap Joint (on outside edge of flanges) or Flare-Bevel Groove (on flange bend line).

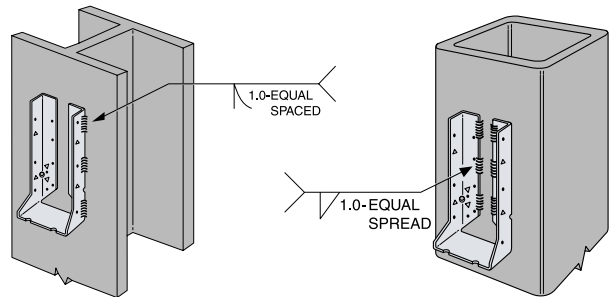

Flare-Bevel Groove Weld
(See Detail)

Lap-Joint Fillet Weld

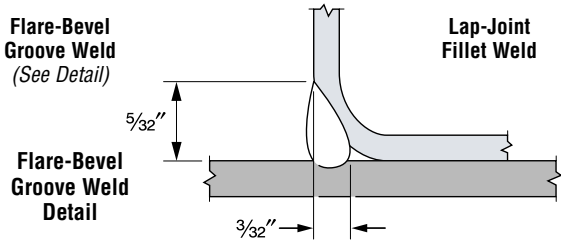

Model Series	Connection Type		Max Allowable Down Load	Code Ref.
	Joist	Structural Steel		
HUC	Screw	Weld	3280	170
	#10	4 - 1" segments		
HUC	#10	6 - 1" segments	4855	170

1. Loads assume an E-70S-6 (60 ksi) filler rod.
2. Welds must conform to the current A.W.S. D1.3 structural welding code for sheet steel and must be performed by certified welder.
3. Designer shall ensure that the joist member adequately transfers load to hanger.
4. Hanger-to-joist connection shall be made using screws on the side of the hanger where it meets the web of the joist.

Installation for CFS Built-Up Beam
 The Designer is responsible for design of beam member.

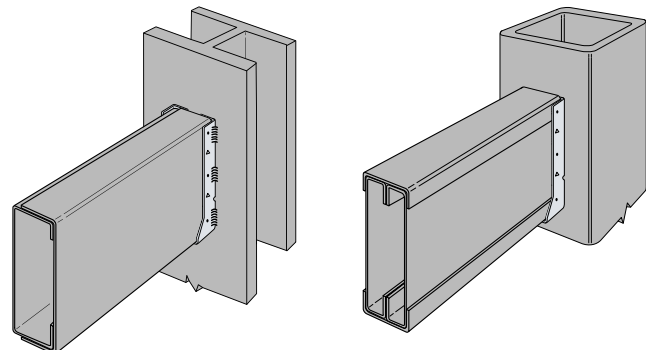

TB/LTB Bridging

TB and LTB bridging are a cost effective way to provide bracing between floor joists when compared with field fabricated blocking and clip angles with multiple fasteners.

TB—Tension-type bridging with maximum fastener flexibility. Use two #10 screws of the seven screw holes at each end.

LTB—Staggered fastener pattern accommodates 6" to 12" web height. Use two #10 Screw of the holes at each end.

MATERIAL: LTB—27 mil (22 ga); TB—33 mil (20 ga)

FINISH: Galvanized

INSTALLATION:

- Bridging will fit flange widths from 1 5/8" to 3".
- Reference section R505.3.3 of the International Residential Code (IRC).

CODE: See page 8 for Code Listing Key Chart.

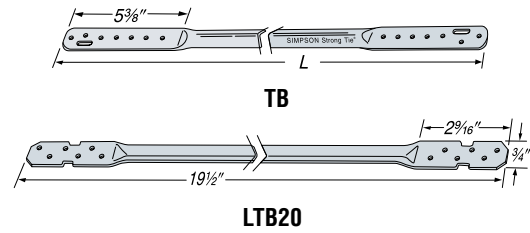

Web Height	Spacing	TB		LTB		Code Ref.
		Model No.	L	Model No.		
6"	12" o.c.	TB20	20	LTB20		ILC1 LC1
8"	12" o.c.	TB20	20	LTB20		
10"	12" o.c.	TB20	20			
12"	12" o.c.	TB27	27	—		
6"	16" o.c.	TB27	27	—		
8"	16" o.c.	TB27	27	—		
10"	16" o.c.	TB27	27	—		
12"	16" o.c.	TB27	27	—		
10"	24" o.c.	TB36	36	—		
12"	24" o.c.	TB36	36	—		

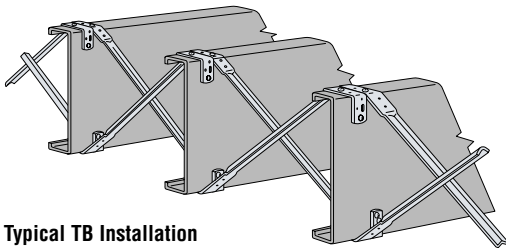

Typical TB Installation

TJC37 Jack Truss Connector

TJC37 is a versatile connector for skewed members. Adjustable from 0 to 67.5 degrees (shipped with 67.5 degree bend). Screw hole locations allow for easy installation.

MATERIAL: 54 mil (16 ga)

FINISH: Galvanized

INSTALLATION: • Use all specified fasteners; see General Notes.

- Can be installed filling round holes only, or filling round and triangle holes for maximum values.
- Position the skewed member on the inside of the bend line with the end of the member flush with the bend line.
- Bend the TJC37 to the desired position (*one bend cycle only*).

CODE: See page 8 for Code Listing Key Chart

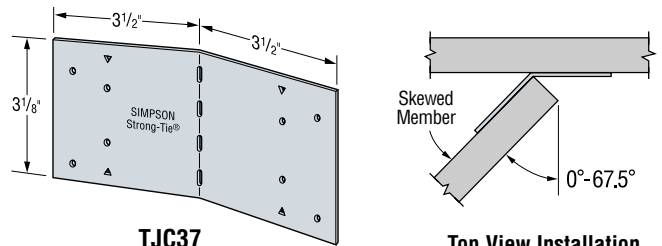

TJC37

Top View Installation

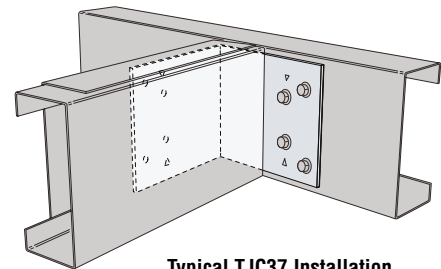

Typical TJC37 Installation

Model No.	Fasteners		Allowable Loads			Code Ref.
	Carrying Member	Carried Member	43 mil (18 ga)			
			0°	1°-60°	61°-67.5°	
TJC37 (Min)	4-#10	4-#10	660	565	475	FC1
TJC37 (Max)	6-#10	6-#10	680	630	530	

1. Allowable loads are for upward or downward direction.

S/DSC Drag Strut Connector

The S/DSC is used as a drag strut to transfer loads from roof framing to the wall plates below.

MATERIAL: 229 mil (3 ga)

FINISH: Simpson Gray Paint

INSTALLATION: • Use all specified fasteners; see General Notes.

CODES: See page 8 for Code Listing Key Chart.

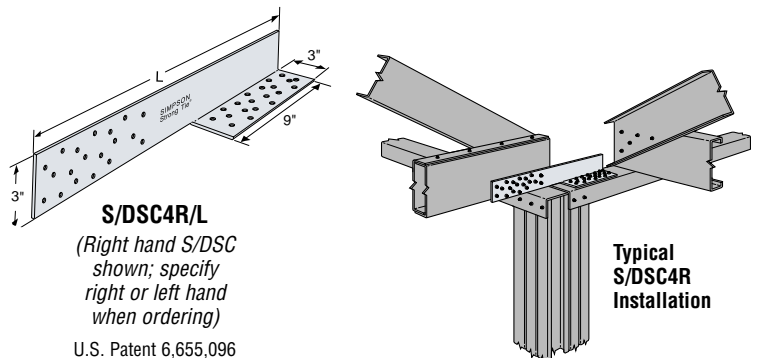

S/DSC4R/L
(Right hand S/DSC shown; specify right or left hand when ordering)

Typical S/DSC4R Installation

U.S. Patent 6,655,096

AHEP Adjustable Hip-End Purlin

The Simpson Strong-Tie AHEP is a structural purlin that also serves as an installation aid during the truss erection process. The AHEP attaches to the step-down hip trusses at the leading edge eliminating the need for drop top chords and C-stud fillers. The AHEP installs linearly, aligned with the end jacks, to maintain sheathing spacing from eave to hip or peak. Roof sheathing/decking attaches directly to the purlin. Adjustable in length, the AHEP is designed to accommodate a pitch range of 3/12 to 9/12.

MATERIAL: 33 mil (20 ga)

FINISH: Galvanized

INSTALLATION: Use all specified fasteners. See General Notes.

CODES: See page 8 for Code Reference Key Chart.

Available June 2010

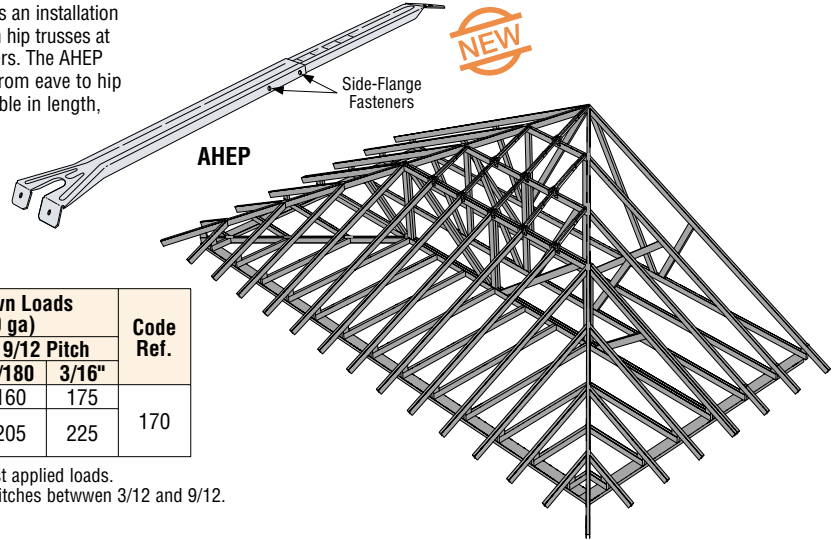

Model No.	Fasteners		Sheathing Option	Allowable Down Loads 33 mil (20 ga)				Code Ref.
	Side Flanges	Truss Ends		3/12 Pitch		9/12 Pitch		
				L/180	3/16"	L/180	3/16"	
AHEP	4 - #10	4 - #10	None	285	360	160	175	170
			1/2" Wood Sheathing	285	360	205	225	

1. Designer shall insure attached members are adequately designed to resist applied loads.
2. Straight line interpolation can be used to determine allowable loads for pitches between 3/12 and 9/12.

TBD22 Truss Brace Diagonal

The TBD22 diagonal truss brace offers a time-saving substitute for hat channel or C-stud diagonal bracing that helps meet the prescriptive recommendations of CFSBCSI. The TBD22 travels in a box like a flat strap (160 feet per carton), and is formed into an A-shape as it is pulled from the carton to provide rigidity and prevent sagging between trusses during installation. As it is fastened to the trusses the brace flattens, allowing sheathing to be installed over it, saving the time typically needed to remove bracing prior to applying the sheathing or decking.

MATERIAL: 27 mil (22 ga)

FINISH: Galvanized

INSTALLATION: Use all specified fasteners; see General Notes

- Strap does not have holes for fasteners. Screws shall be installed in the dimpled areas and placed to maintain a minimum of 1/4" strap edge distance and a minimum of 1/2" center to center distance.
- TBD22 strap span diagonally at approximately 45 degrees.
- Strap shall not be slack, but tight and ready to engage in tension.
- To resist construction forces, diagonal X-bracing is required at each end and every 10 truss spaces (20' max.). Refer to SBCA CFS-BCSI for additional information.
- At the end of the TBD22 braces, trusses shall be laterally restrained to resist out-of-plane forces.
- Bracing locations shown in the drawing are recommendations for temporary bracing only. Installation of TBD22 for permanent bracing shall be by the Building Designer or Engineer of Record.

CODES: See page 8 for Code Reference Key Chart.

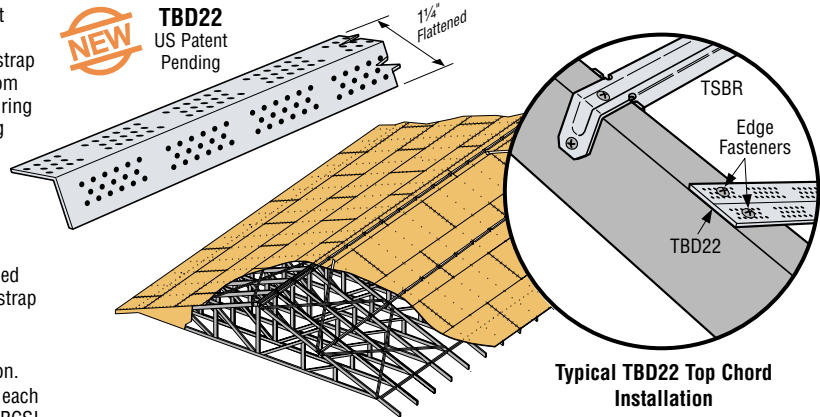

Model No.	Fasteners		Allowable Tension Loads		Code Ref.
	Strap Ends	Intermediate Trusses	Truss Member Thickness		
			27 mil (22 ga)	33 mil (20 ga)	
TBD22	2 - #10	2 - #10	380	510	160

1. Load based on truss steel properties of Fy=50 ksi and Fu=65 ksi. Reduce load directly proportionally for lower steel strength per AISI 2001 Chapter F, Section F1.1 (c).

TSBR and S/TSR Truss Spacer Restraint

The TSBR and the S/TSR captures the on-center spacing of CFS truss chords and webs and laterally restrains the truss members, allowing quicker, easier and safer installations. Its tubular shape provides strength in both compression and tension. S/TSR installs in a linear fashion and has a low profile that can be sheathed over, eliminating the need to remove bracing prior to applying the sheathing or decking.

MATERIAL: 27 mil (22 ga)

FINISH: Galvanized

INSTALLATION: • Use all specified fasteners; see General Notes.

CODES: See page 8 for Code Reference Key Chart.

Available June 2010

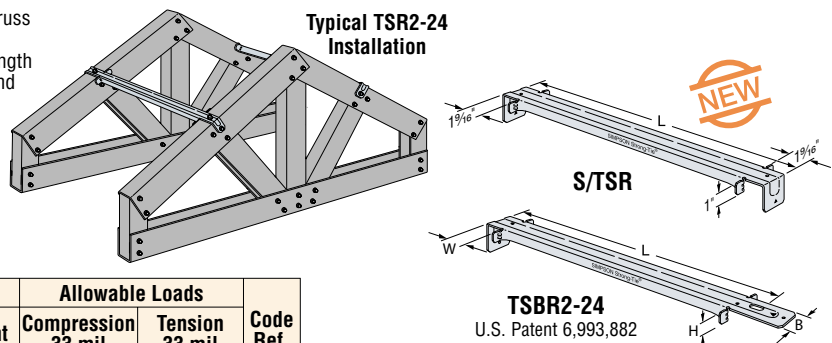

Model No.	Dimensions				Fasteners		Allowable Loads		Code Ref.
	W	L ²	H	B	Bend End	Straight End	Compression 33 mil (20ga)	Tension 33 mil (20ga)	
TSBR2-24	1 1/2	25 1/2	1	1 3/4	1 - #10	1 - #10	455	215	170
					2 - #10	2 - #10	455	575	
S/TSR1.5-24	1 1/2	25 1/2			1 - #10 ⁴	2 - #10	455	425	
S/TSR1.5-24T ³	1 1/2	25 1/2			1 - #10 ⁴	2 - #10	360	425	
S/TSR1.62-24	1 1/2	25 1/2			1 - #10 ⁴	2 - #10	455	425	

1. Designer shall insure attached members are adequately designed to resist applied loads.
2. Length, L, equals the effective out-to-out dimension of the braced trusses.
3. For use with the Alpine or TrusSteel chord profile.
4. Requires 2 - #10 screws installed at each end of the row of restraints.

STC/STCT/DTC Roof Truss Clips

For alignment control between a roof truss and nonbearing walls; the 1/2" slot permits vertical truss chord movement when loads are applied.

MATERIAL: 43 mil (18 ga)

FINISH: Galvanized

INSTALLATION: • Use all specified fasteners; see General Notes.

- Use STC or DTC depending on required loads.
- STC / STCT / DTC may be used with proprietary material sections. Contact material supplier for specific installation details.
- Use STCT where truss or rafter is separated from the top plate of the nonbearing wall.
- Install slot screws in the middle of the slot.

CODE: See page 8 for Code Listing Key Chart

Model No.	Fasteners		Allowable Loads 33 mil (20 ga)						Code Ref.
	Base	Slot	Without Gap		1/4" Max. Gap		1/4" < Gap < 1/2"		
			F ₁	F ₂	F ₁	F ₂	F ₁	F ₂	
STC	2-#8	1-#8	185	35	135	35	75	35	FC1
STCT	2-#8	1-#8	—	—	—	—	—	—	180
DTC	4-#8	2-#8	200	160	200	160	145	160	FC1

1. Truss or rafter must be bearing on top plate to achieve the allowable loads under "WITHOUT GAP."
2. Clips are required on both sides of the truss to achieve F₁ loads in both directions (stagger parts to avoid screw interferences).

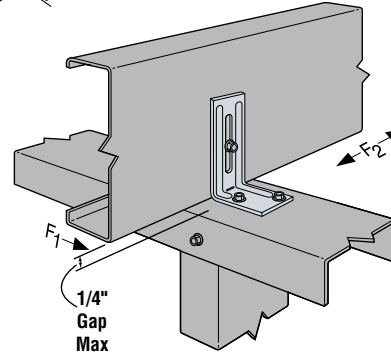
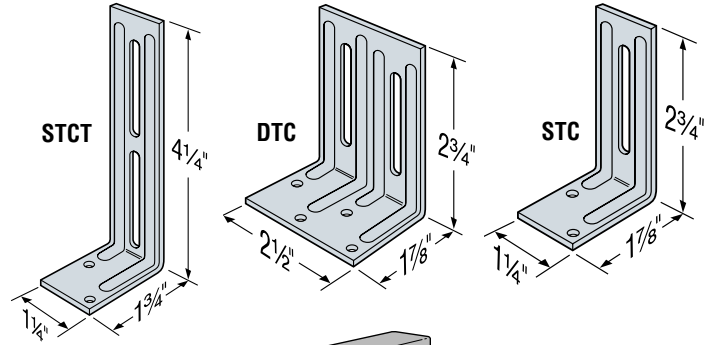

Typical STC Installation

To allow for vertical truss movement, screws into the truss or rafter should not be driven completely flush against the connector.

Truss Connectors

S/GTC Girder Truss Connector

The S/GTC truss connector is designed to connect a carried truss to a girder truss vertical member.

MATERIAL: 33 mil (20 ga)

FINISH: Galvanized

INSTALLATION: • Use all specified fasteners; see General Notes.

- Install the connector onto the girder truss member first.
- May be used with proprietary material sections with web material dimensions from 1 3/8" to 1 5/8". Contact material supplier for product specific installation details.

CODE: See page 8 for Code Listing Key Chart

Model No.	Fasteners		Trusses Material Thickness mil (ga)	Allowable Loads	Code Ref.
	Carried Member	Carrying Member			
S/GTC	4-#10	4-#10	27 (22)	355	170
	4-#10	4-#10	33 (20)	425	
	4-#10	4-#10	43 (18)	450	
	4-#10	4-#10	54 (16)	485	

1. Trusses shall be laterally braced per Designer specification.
2. Allowable loads are for one connector. Up to three connections may be installed; use an adjustment factor of 0.90 to total tabular load.

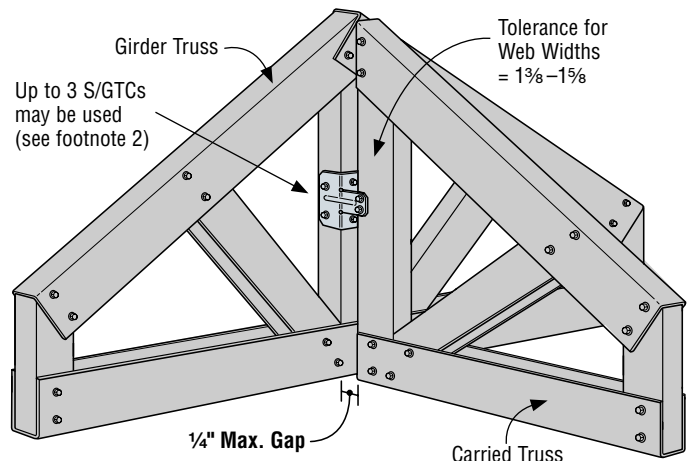
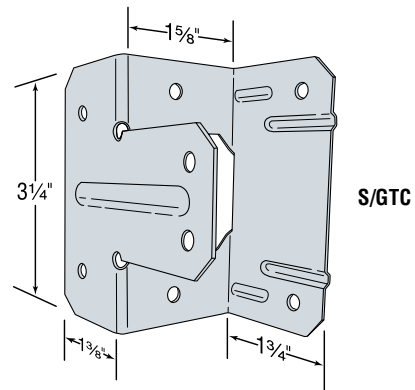

Typical S/GTC Installation

The S/GTC works for many proprietary truss shapes including Alpine, Amkey, Nucon, Nutruss and Steelcon.

S/HTC Heavy Truss Clips

S/HTC provides a slotted connection from the truss or joist to the top track when isolation of two members is required.

MATERIAL: 43 mil (18 ga)

FINISH: Galvanized

INSTALLATION: • Use all specified fasteners.

- Screws in vertical slots shall not be driven completely flush against the connector when vertical movement is desired

CODES: See page 8 for Code Listing Key Chart.

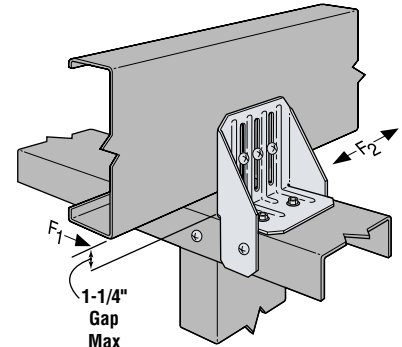
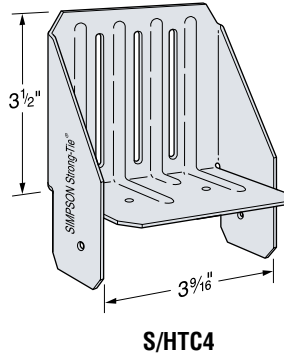

Typical S/HTC4 Installation

Model No.	Fasteners		Allowable Loads 43 mil (18 ga)				Code Ref.
	Top Track	Truss	Without Gap ¹		With 1 1/4" Gap ²		
			F ₁	F ₂	F ₁	F ₂	
S/HTC4	4 - #8	3 - #8	320	460	85	175	FC1

1. Truss or rafter must be bearing on top plate to achieve the allowable loads under "WITHOUT GAP."
2. Installed with maximum 1 1/4" space between rafter or truss and top plate under "WITH 1 1/4" GAP." Where loads are not required, space is not limited to 1 1/4" .

Truss Connectors

Straps & Ties

LTS/MTS/HTS Twist Straps

Twist straps provide a tension connection between two members. They resist uplift at the heel of a truss economically. The 3" bend section eliminates interference at the transition points between steel members.

MATERIAL: See table

FINISH: Galvanized. Some products available in stainless steel and ZMAX[®]; see Corrosion Information, page 12–13.

INSTALLATION: Use all specified fasteners. See General Notes.

CODES: See page 8 for Code Listing Key Chart.

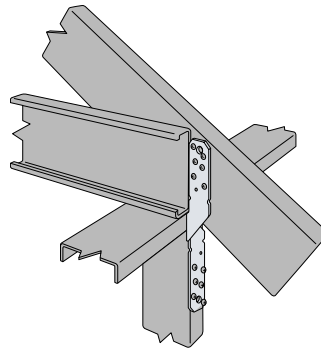

Typical MTS Installation Truss to Steel Studs

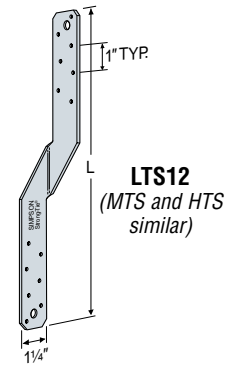

LTS12 (MTS and HTS similar)

Available with additional corrosion protection. Check with Simpson Strong-Tie.

Model No.	Connector Material Thickness mil (ga)	L	Fasteners (Total)			Allowable Tension Loads	Code Ref.
			Rafter/Stud/Joist Thickness				
			33 mil (20 ga)	43 mil (18 ga)	54 mil (16 ga)		
LTS12	43 (18 ga)	12	10-#10	6-#10	6-#10	775	ILC1, LC1, FC1
LTS16		16	10-#10	6-#10	6-#10	775	
LTS18		18	10-#10	6-#10	6-#10	775	
LTS20	54 (16 ga)	20	10-#10	6-#10	6-#10	775	ILC1, LC1, FC1
MTS12		12	12-#10	8-#10	6-#10	995	
MTS16		16	12-#10	8-#10	6-#10	995	
MTS18		18	12-#10	8-#10	6-#10	995	
MTS20		20	12-#10	8-#10	6-#10	995	
MTS30		30	12-#10	8-#10	6-#10	995	
MTS24C		24	12-#10	8-#10	6-#10	995	
MTS30C		30	12-#10	8-#10	6-#10	995	
HTS16		68 (14 ga)	16	16-#10	12-#10	6-#10	
HTS20	20		18-#10	12-#10	6-#10	1450	
HTS24	24		18-#10	12-#10	6-#10	1450	
HTS28	28		18-#10	12-#10	6-#10	1450	
HTS30	30		18-#10	12-#10	6-#10	1450	
HTS30C	30		18-#10	12-#10	6-#10	1450	

1. Not all fastener holes need to be filled as additional fastener holes are provided. Install fasteners symmetrically.
2. Install half of the fasteners on each end of strap to achieve full loads.
3. All straps except the MTS30 and HTS30 have the twist in the center of the strap.
4. Twist straps do not have to be wrapped over the truss to achieve the load.
5. May be installed on the inside face of the stud.

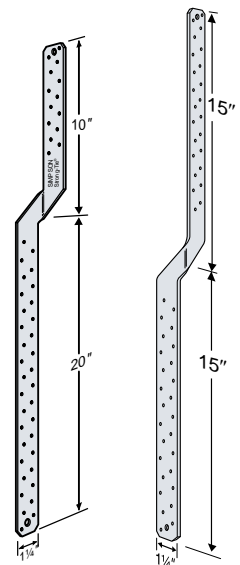

MTS30 (HTS30 similar)

MTS30C (HTS30C similar)

HRS/ST/FHA/PS/LSTA/LSTI/S/MST/MSTA/MSTC/MSTI *Strap Ties*

Straps are load rated and provide the correct thickness and number of fasteners the specifier is looking for compared with field fabricated straps.
 Install Strap Ties where top or bottom plates are cut, at wall intersections, and as ridge ties. Reduce the allowable load based on the size and quantity of fasteners used.
 Refer to applicable code for minimum edge and end distances.

FINISH: PS—hot-dip galvanized (HDG); all others—galvanized.
 Some products are available in stainless steel or ZMAX®; see Corrosion Information, page 12–13.
INSTALLATION: Use all specified fasteners. See General Notes.
CODES: See page 8 for Code Listing Key Chart.

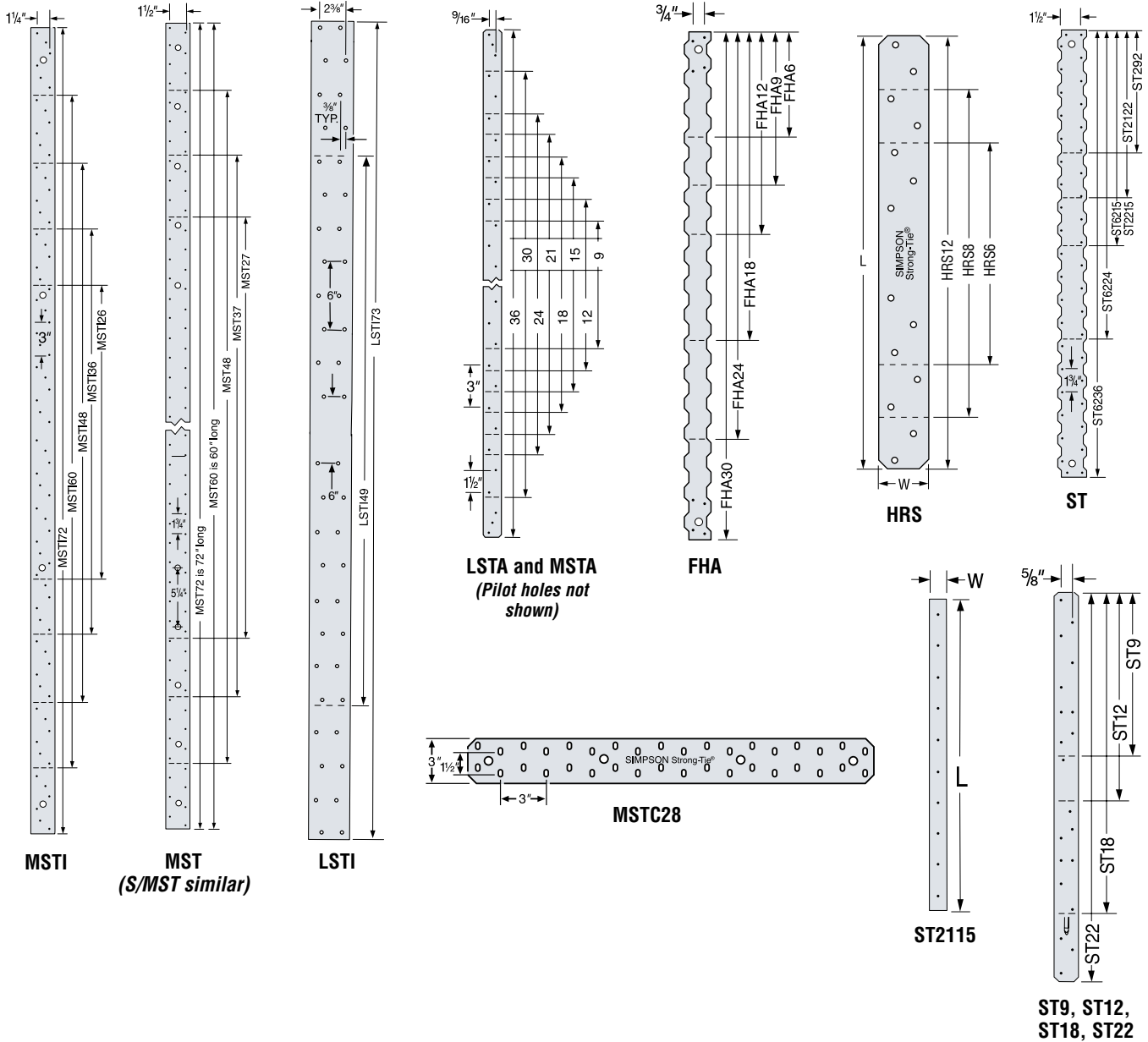

C-CFS10 © 2010 SIMPSON STRONG-TIE COMPANY INC.

Straps & Ties

Model No.	Connector Material Thickness mil (ga)	Dimensions		Bolts		Code Ref.
		W	L	Qty	Dia	
PS218	171 mil (7 ga)	2	18	4	5/8	180
PS418		4	18	4	5/8	
PS720		6 3/4	20	8	1/2	

1. PS strap design loads must be determined by the Designer for each illustration. Hole diameter in the part may be oversized to accommodate the HDG. Designer must determine if the oversize creates an unacceptable installation.

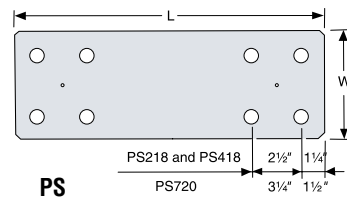

HRS/ST/FHA/LSTA/LSTI/S/MST/MSTA/MSTC/MSTI Strap Ties

Available with additional corrosion protection. Check with Simpson Strong-Tie.

CODES: See page 8 for Code Listing Key Chart.

Model No.	Connector Material Thick. mil (ga)	Dimensions		Fasteners (Total)			Allowable ASD Tension Loads			Code Ref.	
				Rafter/Stud/Joist Thickness			33 mil (20 ga)	43 mil (18 ga)	54 mil (16 ga)		
		W	L	33 mil (20 ga)	43 mil (18 ga)	54 mil (16 ga)					
LSTA9	33 (20 ga)	1¼	9	8- #10	8- #10	8- #10	705	1120	1190	FC1	
LSTA12		1¼	12	10- #10	10- #10	8- #10	885	1190	1190		
LSTA15		1¼	15	12- #10	12- #10	10- #10	1060	1190	1190		
LSTA18		1¼	18	14- #10	12- #10	10- #10	1190	1190	1190		
LSTA21		1¼	21	14- #10	12- #10	10- #10	1190	1190	1190		
LSTA24		1¼	24	14- #10	12- #10	10- #10	1190	1190	1190		
ST292	33 (20 ga)	2½	9½	12- #10	10- #10	10- #10	1060	1240	1240	ILC1, LC1, FC1	
ST2122		2½	12½	16- #10	12- #10	10- #10	1415	1502	1502		
ST2115		¾	16½	8- #10	6- #10	4- #10	630	630	630		
ST2215	43 (18 ga)	2½	16½	20- #10	14- #10	10- #10	1765	1825	1825	FC1	
LSTA30		1¼	30	18- #10	12- #10	10- #10	1555	1555	1555		
LSTA36		1¼	36	18- #10	16- #10	14- #10	1555	1555	1555		
LSTI49		¾	49	32- #10	32- #10	20- #10	2830	4050	4050		
LSTI73		¾	73	46- #10	32- #10	20- #10	4050	4050	4050		
MSTA9		1¼	9	8- #10	8- #10	8- #10	705	1050	1555		
MSTA12		1¼	12	10- #10	10- #10	8- #10	885	1315	1555		
MSTA15		1¼	15	12- #10	12- #10	10- #10	1060	1555	1555		
MSTA18		1¼	18	14- #10	12- #10	10- #10	1235	1555	1555		
MSTA21		1¼	21	16- #10	12- #10	10- #10	1415	1555	1555		
MSTA24		1¼	24	18- #10	12- #10	10- #10	1555	1555	1555		
MSTA30		54 (16 ga)	1¼	30	22- #10	16- #10	12- #10	1945	1950		1950
MSTA36	1¼		36	24- #10	18- #10	16- #10	1950	1950	1950		
ST6215	2½		16½	20- #10	16- #10	10- #10	1765	2025	2025	ILC1, LC1, FC1	
ST6224	2½		23½	28- #10	20- #10	12- #10	2455	2455	2455		
ST9	1¼		9	8- #10	8- #10	8- #10	705	1050	1350		
ST12	1¼		11½	10- #10	10- #10	8- #10	885	1315	1350		
ST18	1¼		17¾	14- #10	12- #10	12- #10	1235	1350	1350		
ST22	1¼		21½	20- #10	20- #10	20- #10	1350	1350	1350		
MSTC28	3		28¼	36- #10	36- #10	30- #10	3180	4600	4600	FC1	
MSTC40	3		40¼	52- #10	46- #10	46- #10	4595	4600	4600		
MSTC52	3		52¼	54- #10	42- #10	42- #10	4600	4600	4600		
MSTC66	3		65¾	66- #10	46- #10	30- #10	5795	5795	5795		
MSTC78	3	77¾	66- #10	46- #10	30- #10	5795	5795	5795			
ST6236	2½	33½	40- #10	30- #10	18- #10	3535	3760	3760	ILC1, LC1, FC1		
HRS6	97 (12 ga)	1⅝	6	6- #10	6- #10	6- #10	530	790		1600	
HRS8		1⅝	8	10- #10	10- #10	10- #10	885	1315	2670		
HRS12		1⅝	12	14- #10	14- #10	12- #10	1235	1840	2710		
FHA6		1⅞	6⅝	8- #10	8- #10	8- #10	705	1050	2045		
FHA9		1⅞	9	8- #10	8- #10	8- #10	705	1050	2045		
FHA12		1⅞	11⅝	8- #10	8- #10	8- #10	705	1050	2045		
FHA18		1⅞	17¾	8- #10	8- #10	8- #10	705	1050	2045		
FHA24		1⅞	23⅞	8- #10	8- #10	8- #10	705	1050	2045		
FHA30		1⅞	30	8- #10	8- #10	8- #10	705	1050	2045		
MSTI26		2½	26	26- #10	26- #10	22- #10	2300	3420	5025		
MSTI36		2½	36	36- #10	36- #10	22- #10	3180	4735	5025		
MSTI48		2½	48	48- #10	40- #10	22- #10	4240	5025	5025		
MSTI60		2½	60	58- #10	40- #10	22- #10	5025	5025	5025		
S/MST27		2½	27	30- #10	30- #10	22- #10	2650	3945	5025		
S/MST37		2½	37	42- #10	40- #10	22- #10	3710	5025	5025		
S/MST48		2½	48	54- #10	40- #10	24- #10	4770	5155	5155		
S/MST60		118 (10 ga)	2½	60	68- #10	52- #10	30- #10	6010	6650	6650	ILC1, LC1, FC1
S/MST72			2½	72	76- #10	52- #10	30- #10	6650	6650	6650	

1. Use half of the fasteners in each member being connected to achieve the listed loads.
2. Loads are based on lesser of steel capacity or fastener calculation.
3. Not all fastener holes need to be filled as additional fastener holes are provided. Install fasteners symmetrically.

CS/CMST Coiled Straps

CMSTC provides fastener slots for easy installation and coined edges. CS, CMST and CMSTC are continuous utility straps which can be cut to length on the job site. Packaged in lightweight (about 40 pounds) cartons.

FINISH: Galvanized. Some products available in ZMAX® coating; see Corrosion Information, page 12–13.

INSTALLATION: • Use all specified fasteners. See General Notes.

- Refer to the applicable code for minimum edge and end distances.
- The table shows the maximum allowable loads and the screws required to obtain them. See footnote #1. Fewer screws may be used; reduce the allowable load by the code lateral load for each fastener subtracted from each end.

CODES: See page 8 for Code Listing Key Chart.

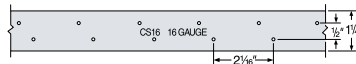

CS16 Hole Pattern
(all other CS straps similar)

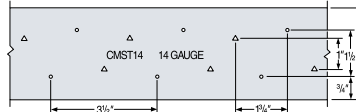

CMST14 Hole Pattern
(CMST12 similar)

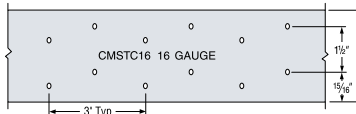

CMSTC16 Hole Pattern

Gauge stamped on part for easy identification

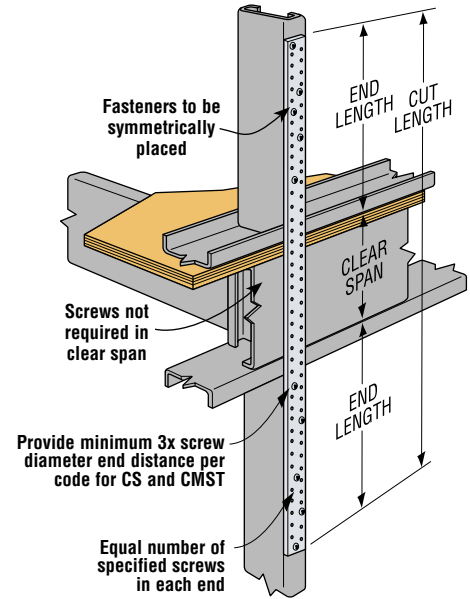

Typical CS Installation
as a Floor-to-Floor Tie

Available with additional corrosion protection. Check with Simpson Strong-Tie.

Model No.	Total length	Connector Material Thickness mil (ga)	Width	Fasteners (Total)			Allowable Tension Loads	Code Ref.
				Rafter/Stud/Joist Thickness				
				33 mil (20 ga)	43 mil (18 ga)	54 mil (16 ga)	33 mil (20 ga) 43 mil (18 ga) 54 mil (16 ga)	
CMST12 ²	40'-3"	97 (12 ga)	3	104- #10	70- #10	40- #10	9080	ILC1, LC1, FC1
CMST14 ²	52 1/2'	68 (14 ga)	3	72- #10	50- #10	28- #10	6365	
CMSTC16 ³	54'	54 (16 ga)	3	54- #10	36- #10	30- #10	4600	
CS14	100'	68 (14 ga)	1 1/4	28- #10	18- #10	12- #10	2305	ILC1, LC1, FC1
CS16	150'	54 (16 ga)	1 1/4	18- #10	12- #10	8- #10	1550	
CS18S	100'	43 (18 ga)	1 1/4	14- #10	10- #10	6- #10	1235	
CS18	200'		1 1/4	14- #10	10- #10	6- #10	1235	
CS20	250'	33 (20 ga)	1 1/4	12- #10	8- #10	6- #10	945	
CS22	300'	27 (22 ga)	1 1/4	10- #10	6- #10	6- #10	775	

1. Use half of the fasteners in each member being connected to achieve the listed loads.
2. For CMST straps: End Length (inches) = 1/2 total fasteners x 7/8" + 1" when all holes filled. Double length if only round holes filled.
3. For CMSTC16 straps: End Length (inches) = 1/2 total fasteners x 3/4" + 1" when all holes filled. Double length if only round holes filled.
4. For CS straps: End Length (inches) = 1/2 total fasteners + 1".
5. Total Cut Length = End Length + Clear Span + End Length.
6. Calculate the connector value for a reduced number of screws as follows: Allowable Load = $\frac{\text{No. of Screws Used}}{\text{No. of Screws in Table}} \times \text{Table Load}$
 Example: CMSTC16 on 54 mil with 24 screws: $\frac{24 \text{ Screws (Used)}}{30 \text{ Screws (Table)}} \times 4600 \text{ lbs} = 3680 \text{ lbs}$
7. Loads are based on lesser of steel strap capacity and 2001 AISI NAS fastener calculation.

SSP/DSP/TSP Stud Plate Ties

The SSP and DSP single- and double-stud plate ties connect single and double studs to top and bottom track. Each can be used for either top- or bottom-track applications.

MATERIAL: SSP/DSP—43 mil (18 ga); TSP—54 mil (16 ga)

FINISH: Galvanized. Some products available in ZMAX®;

see Corrosion Information, page 12–13.

INSTALLATION: • Use all specified fasteners; see General Notes.

• DSP/SSP—top track installation—fill all round and triangle holes

CODES: See page 8 for Code Listing Key Chart.

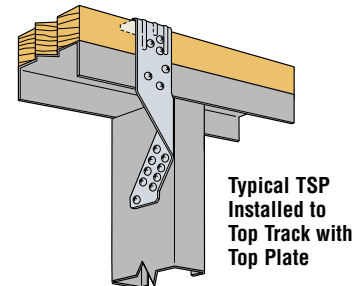
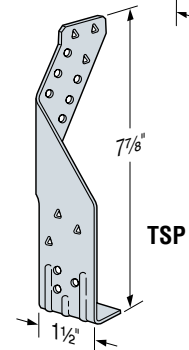
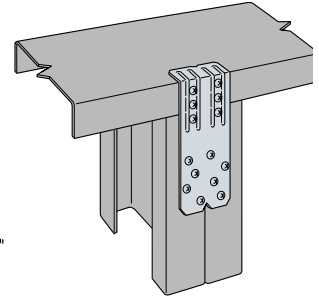
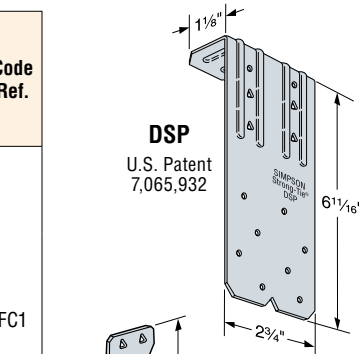
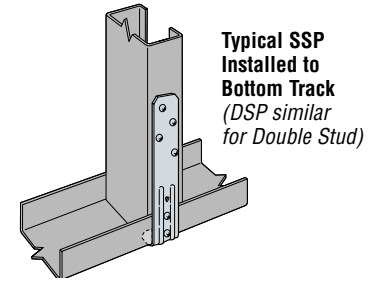
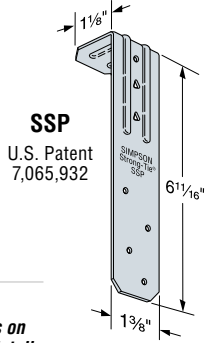

These products are available with additional corrosion protection. Additional products on this page may also be available with this option, check with Simpson Strong-Tie for details.

Model No.	Fasteners				Allowable Uplift Loads		Code Ref.
	Studs	Top Track		Bottom Track	33 mil (20ga)	43 mil (18ga)	
		CFS	Wood	CFS			
SSP	4 - #10	—	—	2 - #10	355	625	FC1
		—	2 - #10	—	340	600	
		2 - #10 ³	1 - #10	—	405 ¹	715 ¹	
		2 - 10d	1 - #10	—	480 ¹	840 ¹	
DSP	8 - #10	—	—	4 - #10	430	695	
		—	4 - #10	—	475	775	
		4 - #10 ³	2 - #10	—	585 ¹	955 ¹	
		4 - 10d	2 - #10	—	730 ¹	1200 ¹	
TSP	6 - #10	—	—	3 - #10	345	645	
		—	3 - #10	—	370	700	
		3 - #10 ³	3 - #10	—	360 ¹	685 ¹	
		3 - 10d	3 - #10	—	480 ¹	905 ¹	

1. For wood plates, noted values only apply to DF/SP members where wood top plates are used. For SPF values, multiply by 0.86.
2. For wood plates, when cross-grain tension cannot be avoided, mechanical reinforcement to resist such forces should be considered.
3. Screws installed into wood plates with a minimum #10x¾".

Straps & Ties

SP Stud Plate Ties



The SP stud plate tie is a plate-to-stud connection providing uplift resistance.

MATERIAL: See table

FINISH: Galvanized. Available with ZMAX® coating; see Corrosion Information, page 12–13.

INSTALLATION: • Use all specified fasteners.

CODES: See page 8 for Code Listing Key Chart.

Available with additional corrosion protection. Check with Simpson Strong-Tie.

Model No.	Connector Material Thickness mil (ga)	Dimensions		Stud Fasteners	Allowable Uplift Loads 33 mil (20 ga)	Code Ref.
		W	L			
SP4	33 (20ga)	3 1/16	7 1/4	6 - #10	825	FC1
SP6	33 (20ga)	5 1/16	7 3/4	6 - #10	825	
SP8	43 (18ga)	7 1/16	8 5/16	6 - #10	930	
SPH4	43 (18ga)	3 1/16	8 3/4	12 - #10	1490	
SPH4R	43 (18ga)	4 1/16	8 3/4	12 - #10	1490	
SPH6	43 (18ga)	5 1/16	9 1/4	12 - #10	1490	
SPH6R	43 (18ga)	6 1/16	8 3/4	12 - #10	1490	
SPH8	43 (18ga)	7 1/16	8 3/8	12 - #10	1490	

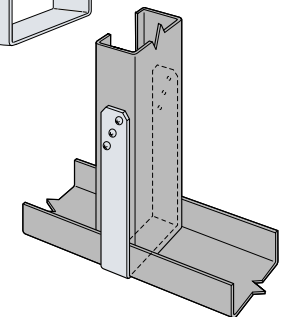
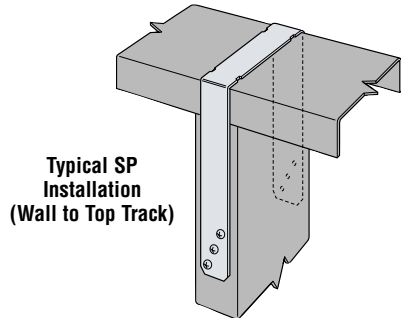
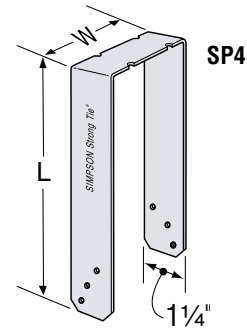

NEW
NEW
NEW
NEW
NEW
NEW
NEW

S/H & H Seismic & Hurricane Ties

Designed to provide seismic and wind ties for trusses or joists, this versatile line may be used for general tie purposes, strongback attachments, and as all-purpose ties where one member crosses another.

MATERIAL: See table

FINISH: Galvanized. Available with ZMAX® coating; see Corrosion Information Connectors, page 12-13.

INSTALLATION: • Use all specified fasteners.

- The S/H1 can be installed with flanges facing outwards (reverse of illustration 1) when installed inside a wall for truss applications.
- Hurricane ties do not replace solid blocking.
- S/H2.5, S/H3 and H6 ties are only shipped in equal quantities of rights and lefts.

CODE: See page 8 for Code Listing Key Chart.

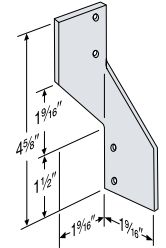
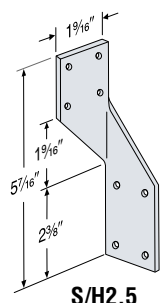
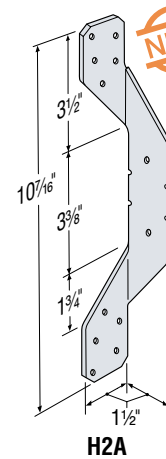
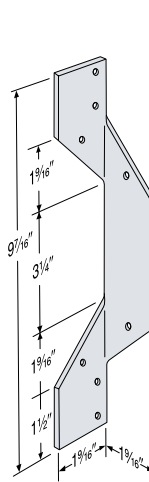
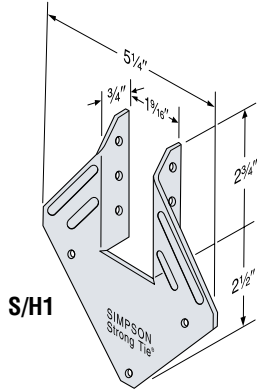

S/H2

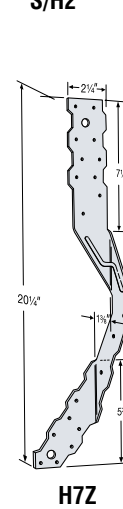

H7Z

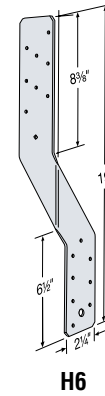

H6

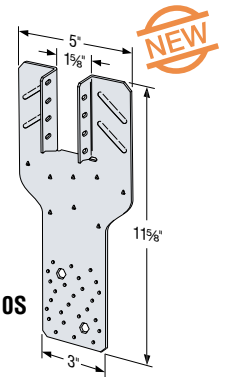

H10S

Available with additional corrosion protection. Check with Simpson Strong-Tie.

Model No.	Connector Material Thickness mil (ga)	Fasteners			Allowable Loads 33 mil (20 ga)			Code Ref.
		To Rafters / Truss	To Top Track	To Stud	Uplift	Lateral		
					F1	F2		
S/H1	43 (18ga)	3 - #10	2 - #10	1 - #10	305	100	115	ILC1, LC1, FC1
S/H2	43 (18ga)	3 - #10	—	3 - #10	315	—	—	
H2A	43 (18ga)	5 - #10	1 - #10	5 - #10	450	90	100	170
S/H2.5	43 (18ga)	4 - #10	—	4 - #10	390	90	125	ILC1, LC1, FC1
S/H3	43 (18ga)	2 - #10	2 - #10	—	375	90	125	
H6	54 (16ga)	—	8 - #10	8 - #10	950	—	—	170
H7Z	54 (16ga)	4 - #10	2 - #10	8 - #10	985	—	—	
H10S ⁴	43 (18ga)	8 - #10	—	8 - #10	930 ³	—	—	

1. Loads are based on attachment of cold-formed steel members having a minimum thickness of 33 mil (20 ga).
2. Hurricane ties are shown installed on the outside of wall for clarity. Installation inside of wall is acceptable. For Continuous Load Path, connections in the same area must be on same side of wall.
3. H10S with CFS members having a minimum thickness of 43mil (18 ga) the allowable load is 1260 lbs.
4. H10S can have an offset of maximum 3/4" from the center of the vertical stud based on AISI General Provisions Standard Section C1 (In-Line Framing) for a reduced uplift of 890 lbs. provided edge distances are met.

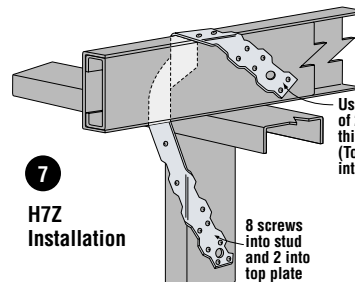
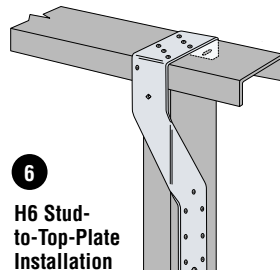
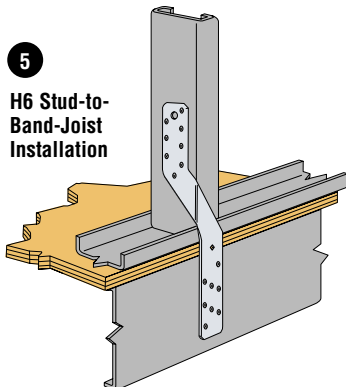
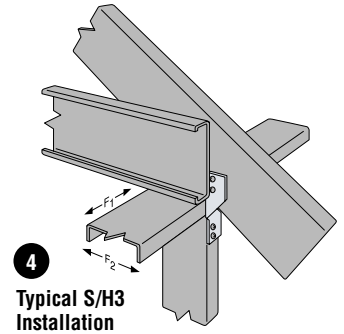
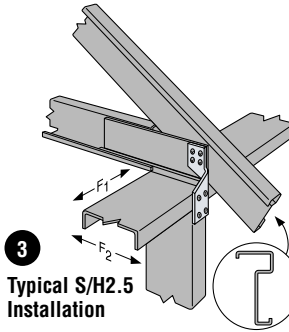
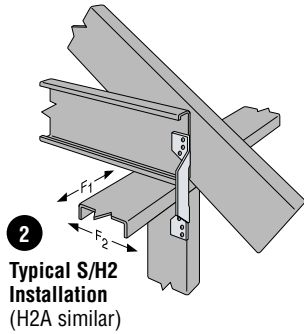
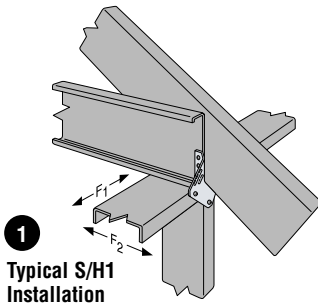

Use a Minimum of 2- #10 screws this side of truss. (Total 4- #10 screws into truss)

8 screws into stud and 2 into top plate

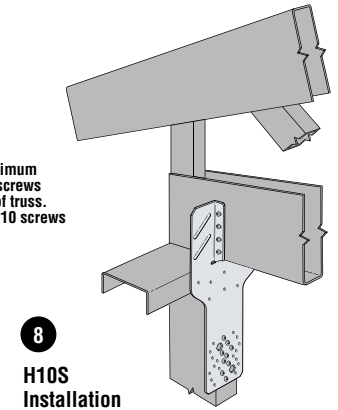

S/H1A Seismic & Hurricane Ties

S/H1A is designed to fit within several proprietary truss chords to provide uplift resistance.

MATERIAL: 43 mil (18 ga)

FINISH: Galvanized

INSTALLATION: • Use all specified fasteners.

- S/H1A can be installed with flanges facing outwards, reverse of illustration, when installed inside a wall for truss applications.
- S/H1A does not replace solid blocking.
- S/H1A may be used with proprietary material sections. Contact material supplier for specific installation details.

CODE: See page 8 for Code Listing Key Chart.

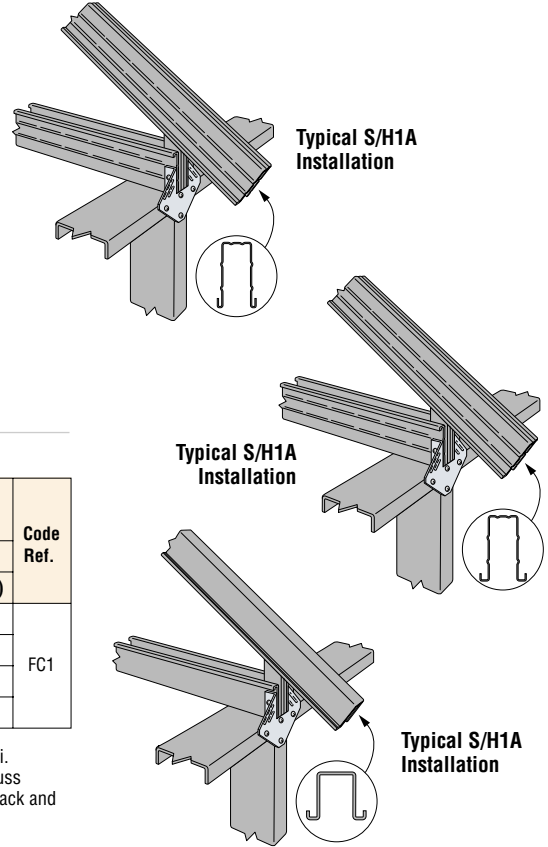
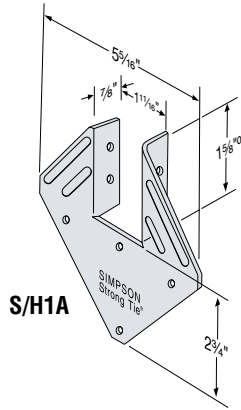

Model No.	Fasteners			Truss Thickness ² mil (ga)	Allowable Uplift Loads			Code Ref.
	Truss	Top Track	Stud		Plate / Wall Stud Thickness mil (ga)			
					33 mil (20 ga)	43 mil (18 ga)	54 mil (16 ga)	
S/H1A	4- #10	3- #10	1- #10	27 (22 ga)	470	470	470	FC1
	4- #10	3- #10	1- #10	33 (20 ga)	510	550	690	
	4- #10	3- #10	1- #10	43 (18 ga)	510	550	690	
	4- #10	3- #10	1- #10	54 (16ga)	520	675	850	

1. Tabulated loads based on truss members with yield strength, F_y , of 50 ksi and tensile strength, F_u , of 65 ksi. Reduce tabulated load proportionally for lower truss member steel strength. For example: 43 mil (18 ga) truss member with a yield strength, F_y of 33 ksi and a tensile strength, F_u , of 45 ksi is connected to 43 mil top track and wall stud. The adjusted allowable load is then 550 lbs. x minimum $[33/50 \text{ or } 45/60] = 363$ lbs.

Straps & Ties

S/PSPN Protecting Shield Plate

S/PSPN58 and S/PSPN516 protecting shield plate fastener stoppers meet IRC, IBC and the International Plumbing Code. S/PSPN516 meets the code plumbing protection requirements as well as having additional fasteners if the Designer chooses to use it as a track splice strap.

MATERIAL: 54 mil (16 ga)

FINISH: Galvanized, available in ZMAX[®]

INSTALLATION: S/PSPN – #10 screws.

CODES: See page 8 for Code Listing Key Chart.

S/PSPN516 at top plates

- International Residential Code[®] – 2000/2003/2006 P2603.2.1
- International Plumbing Code – 2000/2003/2006 305.8

S/PSPN516 at bottom plate.

- International Plumbing Code – 2000/2003/2006 305.8

S/PSPN58 at top plates and bottom plate.

- International Plumbing Code – 2000/2003/2006 305.8

Note that the IBC section 2308.9.8 and the IRC section 602.6.1 require a 54 mil (16 ga) strap with 6-16d nails and 8-16d nails respectively each side at a hole or notch in a wood top, sill or sole plate. The Designer or local building jurisdiction may permit an equivalent fastener strength (i.e. screws in lieu of nails) to be used for the same condition in a CFS top or bottom track.

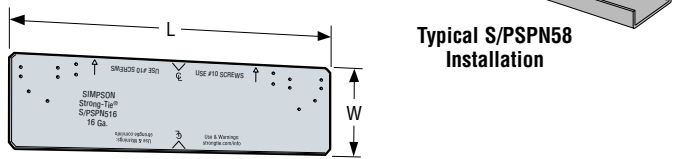
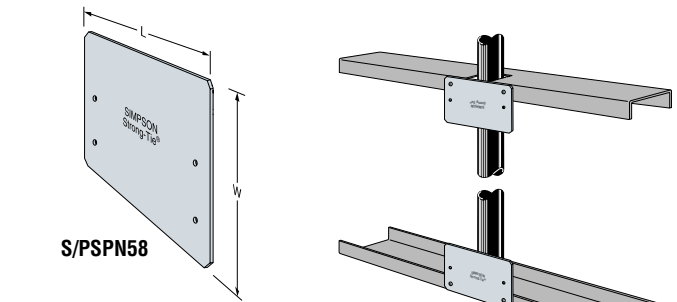

These products are available with additional corrosion protection. Additional products on this page may also be available with this option, check with Simpson Strong-Tie for details.

Model No.	W	L	Code Ref.
S/PSPN58	5	8	190
S/PSPN516	5	16 5/16	

- #10 self-tapping screws may be used to attach S/PSPN to CFS framing with quantity determined by Designer.
- PSPN516 with 6 #10 self-tapping screws each side achieves an allowable shear capacity of 1060 lbs and 1580 lbs to 33 mil (20 ga) track and to 43 mil (18 ga) track, respectively.

H Hybrid Connectors *Seismic & Hurricane Ties for Wood Truss or Joist-to-CFS Wall*

Designed to provide seismic and wind ties for wood trusses or joists-to-CFS walls, this versatile line may be used for general purposes, strongback attachments, and as all-purpose ties where one member crosses another.

HS24 attaches the bottom chord of a truss or rafter at pitches from 0:12 to 4:12 to steel top plates.

Material: See table

Finish: Galvanized. Selected products available in stainless steel or ZMAX® coating. See Corrosion Information, page 12-13.

Installation: • Use all specified fasteners. See General Notes

- H1 can be installed with flanges facing inward (reverse of illustration 1).
- Hurricane ties do not replace solid blocking.
- H2.5, H3, and H6 ties are only shipped in equal quantities of rights and lefts.

Codes: See page 8 for Code Listing Key Chart.

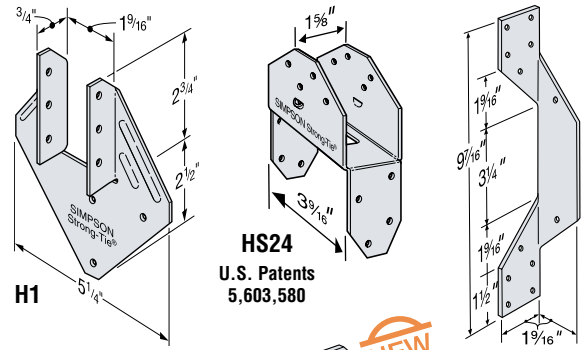

HS24
U.S. Patents
5,603,580



H2

Available with additional corrosion protection. Check with Simpson Strong-Tie.

Model No.	Connector Material Thickness mil (ga)	Fasteners			Allowable Uplift Loads 33 mil (20 ga) (160)		Code Ref.
		To Rafters / Truss	To Top Track	To Stud	DF/SP	SPF/HF	
H1	43 (18ga)	6 - 8dx1 1/2	3 - #10	1 - #10	600	500	170
H2	43 (18ga)	5 - 8dx1 1/2	—	5 - #10	345	290	
H2A	43 (18ga)	5 - 8dx1 1/2	1 - #10	5 - #10	550	460	
H2.5	43 (18ga)	5 - 8dx1 1/2	3 - #10	2 - #10	435	365	
H3	43 (18ga)	4 - 8dx1 1/2	4 - #10	—	365	305	
H6	54 mil (16)	—	8 - 8d	8 - #10	950	820	
H7Z	54 mil (16)	4 - 8dx1 1/2	2 - #10	8 - #10	985	845	
HS24	43 (18ga)	8 - 8dx1 1/2	4 - #10	4 - #10	625	520	
H10S ⁵	43 (18ga)	8 - 8dx1 1/2	—	8 - #10	930	780	

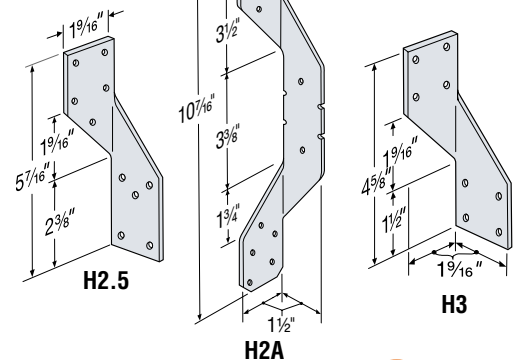

H2.5

H2A

H3

1. Allowable loads on wood have been increased 60% for wind or earthquake loading with no further increase allowed; reduce where other load duration factors govern.
2. Loads are based on attachment of cold-formed steel vertical stud members having a minimum thickness of 33 mil (20 ga).
3. Hurricane Ties are shown installed on the outside of wall for clarity. Installation inside of wall is acceptable. For Continuous Load Path, connections must be on same side of wall.
4. When cross-grain bending or cross-grain tension cannot be avoided, mechanical reinforcement to resist such force should be considered.
5. H10S can have an offset of maximum 3/4" from the center of the CFS vertical stud based on AISI General Provisions Standard Section C1 (In-Line Framing) for a reduced uplift of 890 lbs. (DF/SP) and 765 lbs. (SPF) provided all edge distances are met.

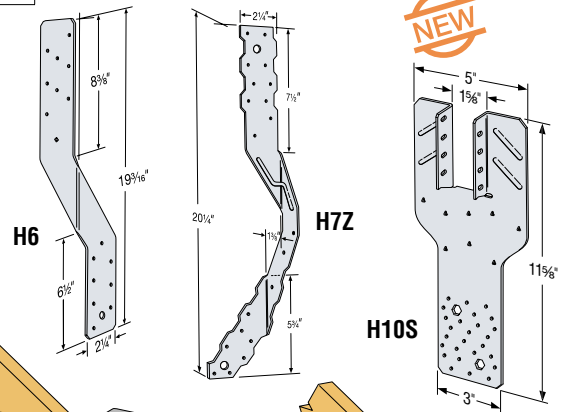

H6

H7Z

H10S

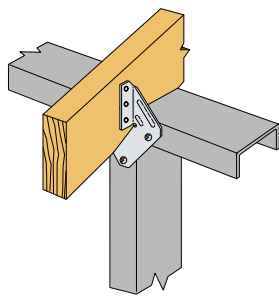

1 H1 Installation

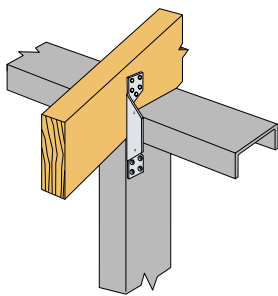

2 H2 Installation (H2A similar)

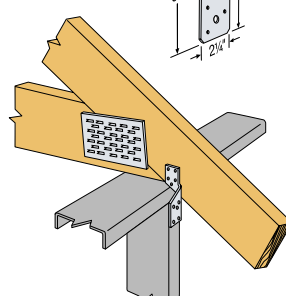

3 H2.5 Installation

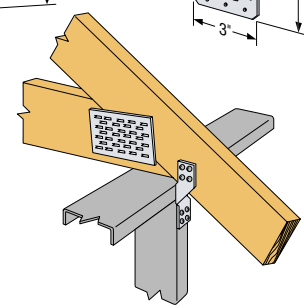

4 H3 Installation

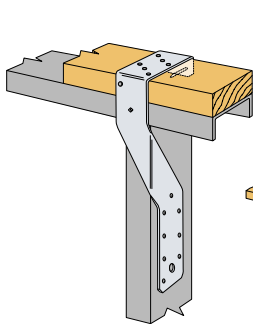

5 H6 Stud-to-Top-Plate Installation

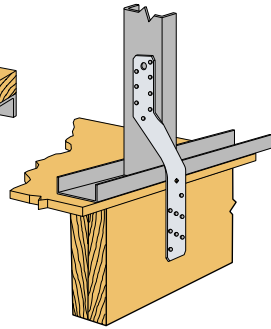

6 H6 Stud-to-Band-Joist Installation

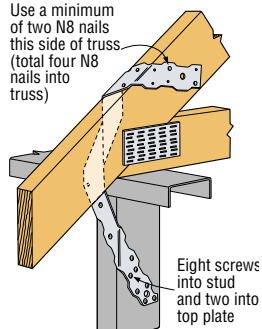

7 H7Z Installation

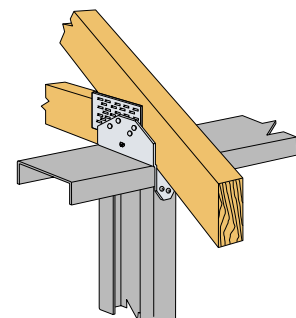

8 HS24 Installation

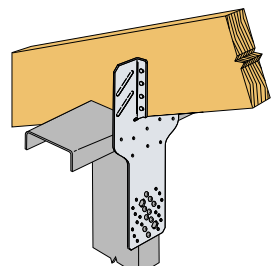

8 H10S Installation

VGT and S/VGT2.5 Variable-Pitch Girder Tiedowns

The variable-pitch girder tiedown, S/VGT2.5, is a high-capacity tiedown for single-or multi-ply CFS girder trusses. It attaches with self-drilling screws from the side of the truss. The VGT uses Simpson Strong-Tie SDS series screws for wood truss applications. They both feature a predeflected crescent washer which allows them to accommodate top-chord pitches up to 8/12.

MATERIAL: 171 mil (7 ga)

FINISH: Galvanized

INSTALLATION: • Use all specified fasteners

- Screw holes are configured to allow for double installation on multi-member girders.
- Install washer component (provided) so that top of washer is horizontal and parallel with top of wall.

CODES: See page 8 for Code Listing Key Chart.

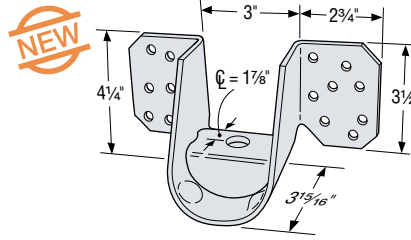

VGT
U.S. Patent Pending

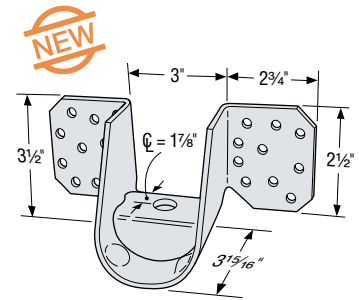

S/VGT2.5
U.S. Patent Pending

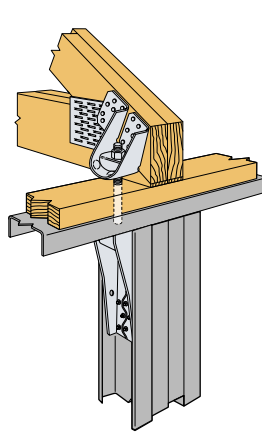

Typical Hybrid VGTR Single Installation with S/HDU4

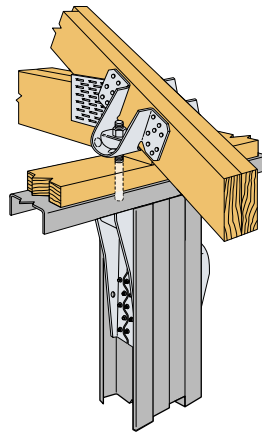

Typical Hybrid VGT Double Installation with S/HDU6

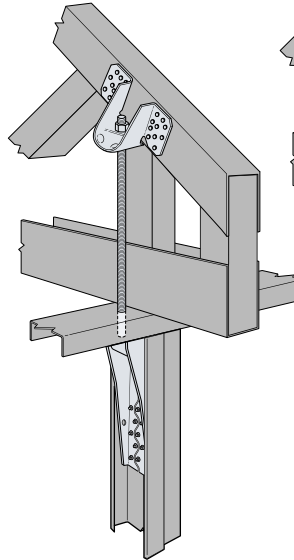

Typical S/VGT2.5 Single Installation

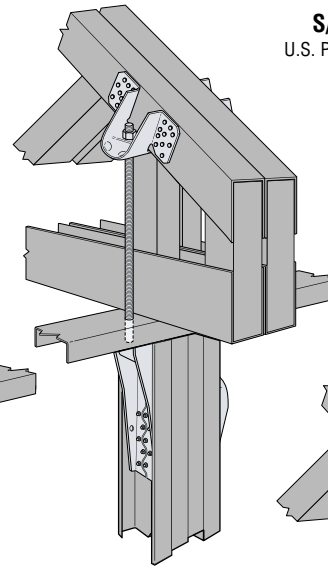

Typical S/VGT2.5 Double Installation with S/HDU6

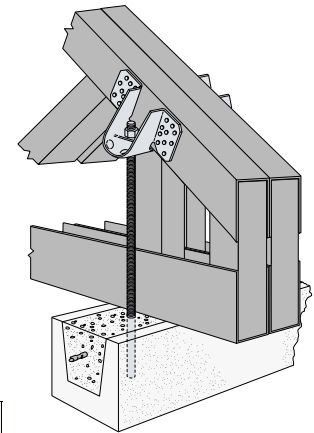

Typical S/VGT2.5 Installation in CMU

Model No.	Quantity	No. of Truss Plies	Fasteners		Allowable Uplift Loads ²		Code Ref.
			Anchor Dia.	Girder Truss	3/12	8/12	
Cold-Formed Steel Connection					54mil (16ga)		
S/VGT2.5 (min)	1	1	1 - 5/8"	16 - #14	3050	2620	170
	2	2	2 - 5/8"	32 - #14	6100	5240	
S/VGT2.5 (max)	1	1	1 - 5/8"	20 - #14	3860	3130	
	2	2	2 - 5/8"	40 - #14	7720	6260	
Hybrid Connection					Allowable Uplift Loads³ up to 8/12		Code Ref.
					DF/SP (160)	SPF/HF (160)	
VGT	1	2	1 - 5/8"	16 - SDS 1/4"x3"	4940	3555	F26
	2	2	2 - 5/8"	32 - SDS 1/4"x3"	7185	5175	
	2	3	2 - 5/8"	32 - SDS 1/4"x3"	8890	6400	
VGTR/L	1	2	1 - 5/8"	16 - SDS 1/4"x3"	2230	1605	
	2	2	2 - 5/8"	32 - SDS 1/4"x3"	5545	3990	

1. Designer shall insure attached members are adequately designed to resist applied loads.
 2. Straight-line interpolation can be used to determine allowable loads for pitches between 3/12 and 8/12.
 3. Allowable loads on wood have been increased 60% for wind or earthquake loading with no further increase allowed; reduce where other load duration factors govern.

MTSM/HTSM Twist Straps

The MTSM and HTSM offer high strength truss to masonry connections.

MATERIAL: See table

FINISH: Galvanized. Some products available in stainless steel and ZMAX®; see Corrosion Information, page 12-13.

INSTALLATION: • Use all specified fasteners. See General Notes.

- May be attached to either side of a grouted block wall. A minimum of one #5 horizontal rebar shall be installed in the top course of this wall.

CODES: See page 8 for Code Listing Key Chart.

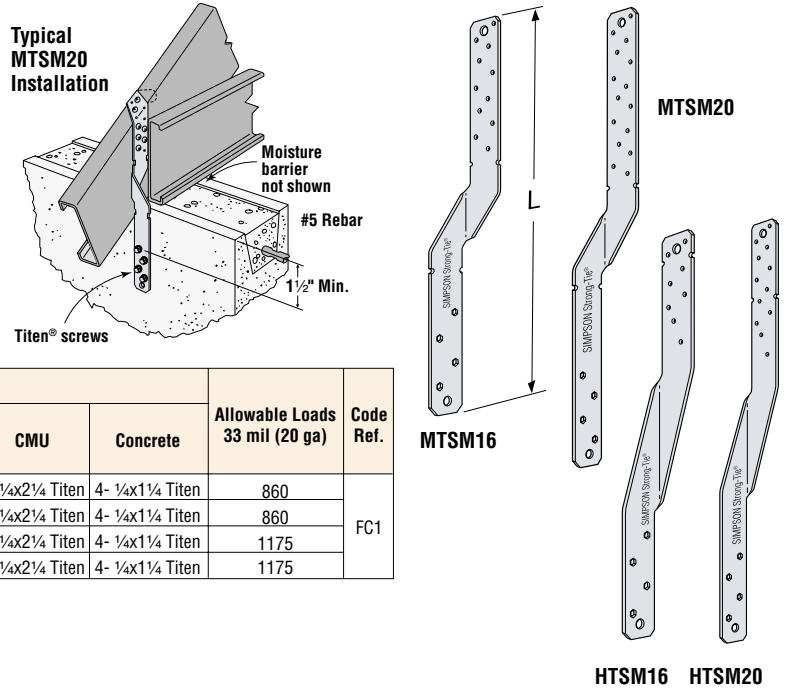

Model No.	Connector Material Thick. mil (ga)	L	Fasteners						Allowable Loads 33 mil (20 ga)	Code Ref.
			Rafter/Stud/Joist Thickness			CMU	Concrete			
			33 mil (20 ga)	43 mil (18 ga)	54 mil (16 ga)					
MTSM16	54 (16 ga)	16	5- #10	4- #10	3- #10	4- 1/4x2 1/4 Titen	4- 1/4x1 1/4 Titen	860	FC1	
MTSM20		20	5- #10	4- #10	3- #10	4- 1/4x2 1/4 Titen	4- 1/4x1 1/4 Titen			
HTSM16	68 (14 ga)	16	7- #10	5- #10	3- #10	4- 1/4x2 1/4 Titen	4- 1/4x1 1/4 Titen	1175		
HTSM20		20	7- #10	5- #10	3- #10	4- 1/4x2 1/4 Titen	4- 1/4x1 1/4 Titen			

1. All straps have additional fastener holes.
2. Twist straps do not have to be wrapped over the truss to achieve the wall.
3. Minimum edge distance in concrete block for Titen screw is 1 1/2".
4. May be installed on the inside face of the wall.
5. Min. f_m = 1500 psi and f_c = 2500 psi.

LTA1, S/HGAM10 and H10S Seismic & Hurricane Ties

The LTA1 develops high uplift at a minimum heel height. Great in areas where a strap over the heel is not required. The side tab acts as a locator in the masonry block and the four embedded hooks provide for a positive bond in the concrete grout.

The H10S and the S/HGAM10 attaches to truss joist and provides good uplift resistance.

MATERIAL: See table

FINISH: Galvanized

INSTALLATION: • Use all specified fasteners. See General Notes.

- S/HGAM10 can be installed into grouted concrete block.
- Titen® screws are provided.
- Hurricane ties do not replace solid blocking.
- Attach to grouted concrete block with a minimum one #5 rebar horizontal in the top lintel block.

CODES: See page 8 for Code Listing Key Chart

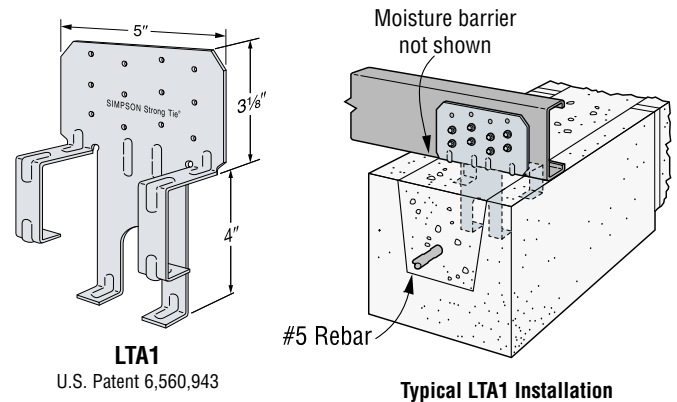

Model No.	Connector Material Thickness mil (ga)	Fasteners			Allowable Uplift Loads		Code Ref.
		To Rafter / Truss	To CMU	To Concrete	33 mil (20 ga)	43 mil (18 ga)	
LTA1	43 (18 ga)	8- #10	—	—	1415	1420	170
S/HGAM10KT	68 (14 ga)	4- #14	4- 1/4" x 2 3/4" Titen	4- 1/4" x 1 3/4" Titen	810	850	LC1
H10S	43 (18 ga)	8- #10	2- 3/8" x 4" Titen HD	2- 3/8" x 4" Titen HD	915	1245	170

1. Min. f_m = 1500 psi and f_c = 2500 psi.
2. Minimum edge distance 1 1/2" using Titen screws.
3. Products shall be installed such that the Titen screws and Titen HD anchors are not exposed to the weather.
4. See page 22 for Titen screw and Titen HD information.

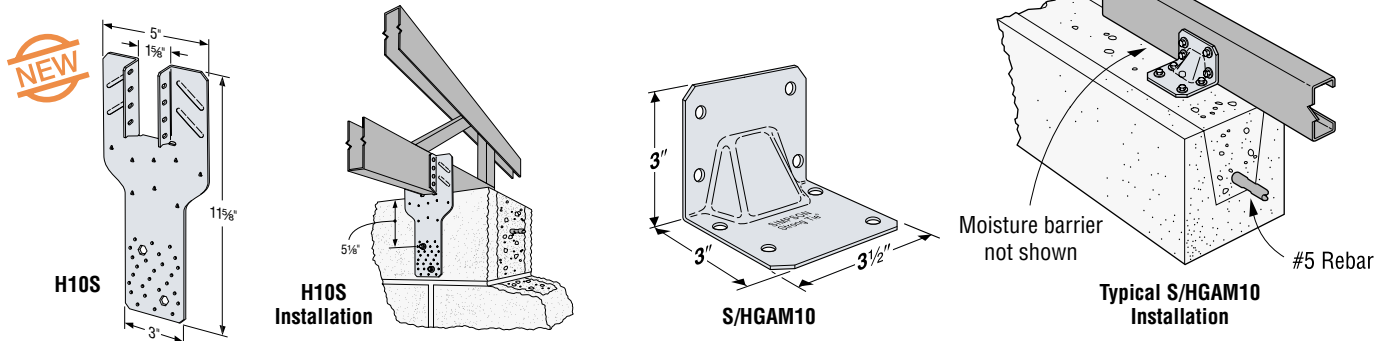

LTP5 Framing Anchor

The LTP5 framing anchor spans subfloor at the top of the blocking or rim joist. The embossments enhance performance and allow for design flexibility.

MATERIAL: 33 mil (20 ga)

FINISH: Galvanized

INSTALLATION:

- Use all specified fasteners. See General Notes.

CODES: See page 8 for Code Listing Key Chart.

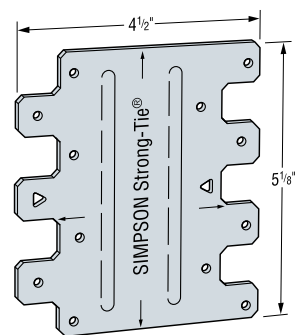

LTP5

Model No.	Type of Connection	Direction of Load	Fasteners		Allowable Loads 43 mil (18 ga)	Code Ref.
			To Rim Joist	To Sheathing & Track		
LTP5	1	G	7- #10	7- #10	1045	FC1
	2		7- #10	7- #10	1110	
	3		7-8d x 1 1/2	7- #10	730	

1. Allowable loads are for one anchor.
2. Allowable loads are based on steel (stud & sheet) of 43 mil (18 ga) minimum.
3. Allowable load for Type 3 connection assumes Cd = 1.60.

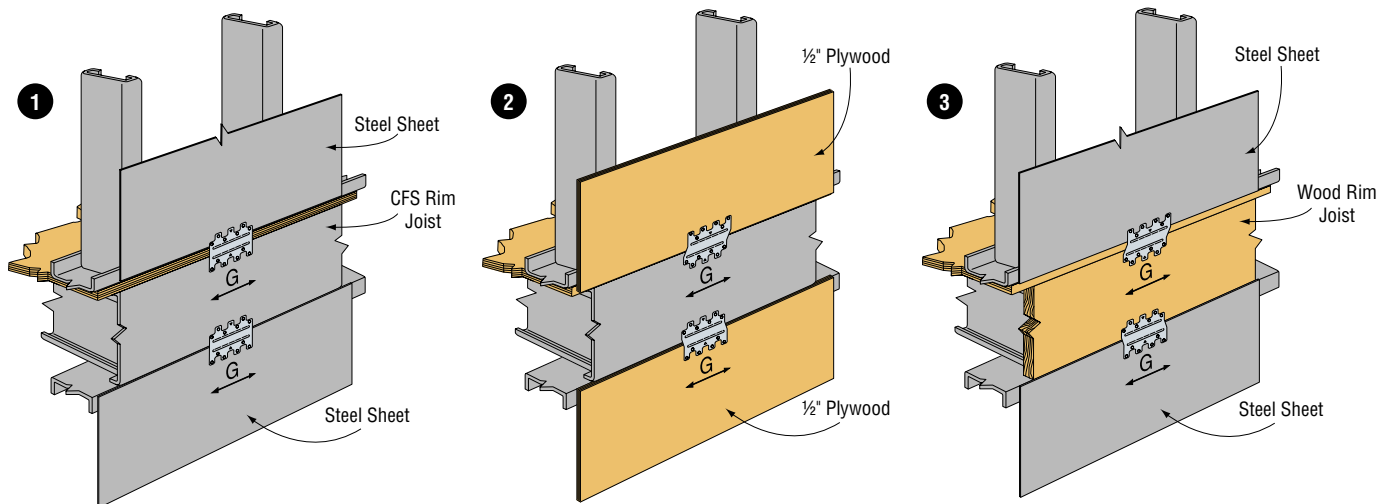

Note: When attaching an LTP5 framing anchor over sheathing, the screws must penetrate and engage the steel framing. A minimum of 3 threads shall penetrate past the steel.

L & S/LS Reinforcing & Skewable Angles

L and S/LS angles are load rated and provide the correct thickness and number of fasteners the specifier is looking for compared with field fabricated clip angles.

General utility reinforcing angles with multiple uses.

S/LS—Field-adjustable angles attach members intersecting at angles.

MATERIAL: L—54 mil (16 ga); S/LS—43 mil (18 ga)

FINISH: Galvanized. Some products available in stainless steel or ZMAX®; see Corrosion Information, page 12–13.

INSTALLATION: • Use all specified fasteners.

- S/LS—field-skewable; bend one time only.
- Joist must be constrained against rotation when using a single S/LS per connection.

CODE: See page 8 for Code Listing Key Chart.

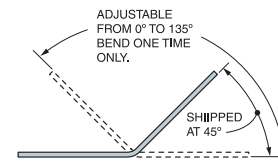
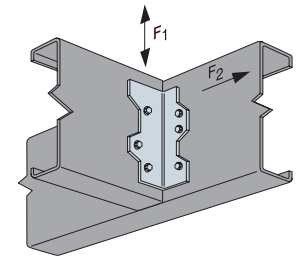
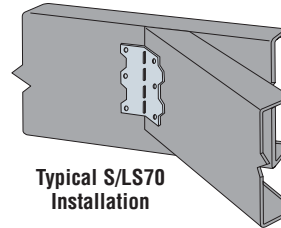
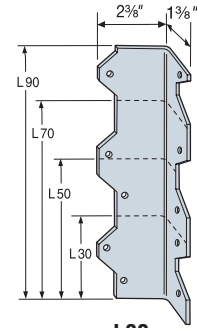
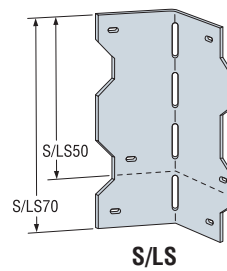

Available with additional corrosion protection. Check with Simpson Strong-Tie.

Model No.	Length	Fasteners	Allowable Loads					Code Ref.
			33 mil (20 ga)		43 mil (18 ga)	54 mil (16 ga)		
			F ₁	F ₂	F ₁	F ₁	F ₂	
L30	3	4- #10	200	60	420	610	–	ILC1, LC1, FC1
L50	5	6- #10	475	–	630	750	110	
L70	7	8- #10	705	–	840	1100	100	
L90	9	10- #10	795	–	1050	1740	–	170
S/LS50	4 7/8	4- #10	200	–	420	500	–	ILC1, LC1, FC1
S/LS70	6 3/8	6- #10	465	–	630	715	–	

1. Loads are for one part only.
2. Code approval is limited for specific steel thickness. Refer to Code Report for additional information.

PSCL/PSCA Panel Sheathing Clips



Simpson Strong-Tie® Panel Sheathing Clips are used to brace unsupported sheathing edges. The PSCA is a new version of the PSCL with less material for a more cost effective solution. Model sizes include: PSCL 3/8, PSCA 7/16, PSCL 7/16, PSCA 1 5/32, PSCL 1 5/32, PSCL 1/2, PSCL 5/8, PSCL 1 1/8, PSCL 3/4.

MATERIAL: 33 mil (20 ga)

FINISH: Galvanized

INSTALLATION:

- Use the same size sheathing clip as the wood panel thickness.
- Spans may be reduced for low slopes (per the APA Residential Design/Construction Guide).

CODES: See page 8 for Code Listing Key Chart.

Span Rating	Wood Panel Thickness	Maximum Roof Span		PSCLs Per Span	Code Ref.
		With PSCL	Without PSCL		
24/0	3/8	24	20	1	180
24/16	7/16	24	24	1	
32/16	1 5/32, 1/2	32	28	1	
40/20	5/8, 1 1/8	40	32	1	
48/24	3/4	48	36	2	

1. Span rating and Maximum Roof Sheathing Spans are for reference only, refer to IBC Table 2304.7 (3) for additional important information.
2. Max. roof sheathing span with single PSCA is 24". For spans greater than 24" use two PSCAs.

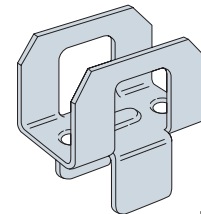

PSCL (PSCA similar)

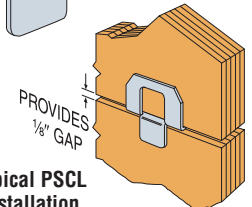

Typical PSCL Installation

TP/TPA Tie Plates

TPs are screw-on tie plates. TPAs are flanged for added support.

MATERIAL: 33 mil (20 ga)

FINISH: Galvanized

INSTALLATION:

- Holes are sized for #8 or #10 screw.

CODES: See page 8 for Code Listing Key Chart.

Model No.	Dimensions		Number of Nail Holes	Code Ref.
	W	L		
TP15	1 13/16	5	13	180
TPA37	3 1/2	7	32	
TPA39	3 1/2	9	41	
TP35	3 1/8	5	23	
TP37	3 1/8	7	32	
TP39	3 1/8	9	41	
TP311	3 1/8	11	50	
TP45	4 1/8	5	30	
TP47	4 1/8	7	42	
TP49	4 1/8	9	54	
TP411	4 1/8	11	66	
TP57	5 3/4	7	60	
TPA57	5	7	49	

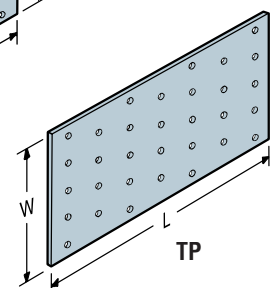
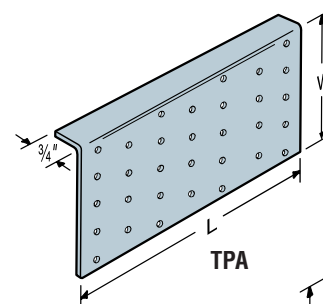

1. Connectors are not load rated.

Special Order Custom Clips and Angles

Simpson Strong-Tie can make a variety of flat and bent steel shapes, which includes clips and angles for CFS applications.

MATERIAL: 229 mil (3 ga) maximum, 43 mil (18 ga) minimum mill certified steel

FINISH: Galvanized, Simpson Strong-Tie gray paint, stainless steel. Contact Simpson Strong-Tie for availability.

TO OBTAIN A QUOTE:

- Supply a CAD drawing in .dwg or .dxf format complete with all dimensions, hole diameter and centerline locations, bend angles, steel strength (Min Fy and Fu), thickness (mils and/or ga) and finish: (galvanized to G-60, G-90, G-185), Simpson Strong-Tie Gray Paint, or stainless steel (specify).
- Total shape and size up to a maximum of 48" x 48" (approx. 1/16" tolerance).
- Simpson Strong-Tie does not provide product engineering or load values for special order custom clips and angles
- Contact Simpson Strong-Tie for pricing information
- Refer to Important Information & General Notes, starting on page 8 for additional information.

EXAMPLE SPECIFICATION:

QUANTITY: XX pieces

DIMENSIONS: Per the attached CAD drawing (.dwg or .dxf format)

• Drawing must be fully dimensioned including:

- Overall dimensions
- Leg dimensions
- Bend Angles (if required)
- Hole sizes and centerlines (if required)

MATERIAL SPECIFICATION: (Contact Simpson Strong-Tie for availability)

THICKNESS: 54 mil (16 ga.)

STRENGTH: Min. Yield Strength (Fy) = 33 ksi, Min. Tensile Strength (Fu) = 45 ksi

FINISH: G-90 galvanizing

Total Number of parts required for this specification: XX

Custom Clips & Angles

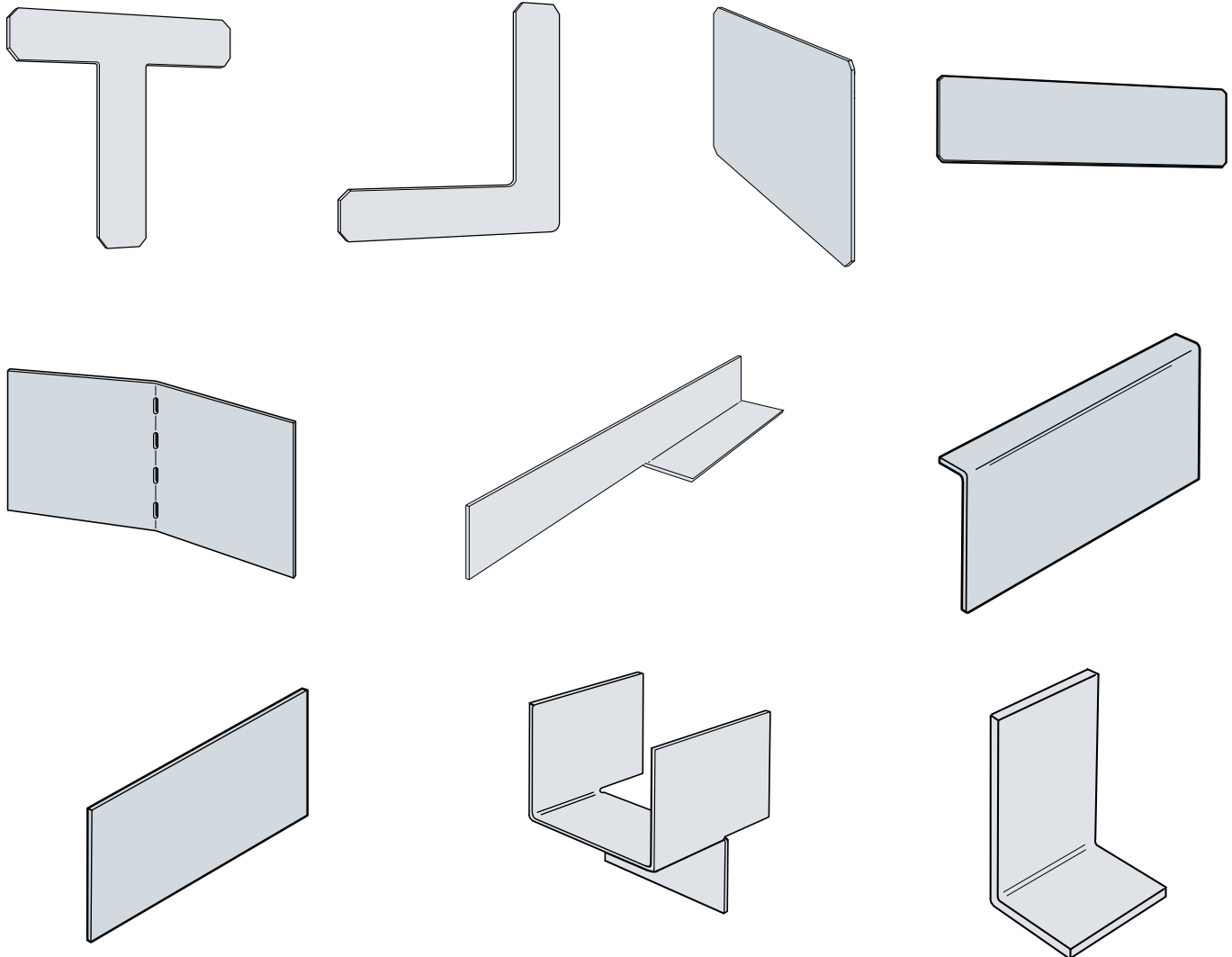

CONTINUOUS LOAD PATH CONSIDERATIONS

Modern design and construction practices use structural connectors to form a continuous load path that can effectively resist wind and seismic forces by reinforcing the structure from the roof to the foundation.

Simpson Strong-Tie® connectors are designed to enable structures to resist the movement, stress, and loading that results from natural events such as earthquakes and high velocity winds. When properly installed, our connectors will perform in accordance with the specifications set forth in this catalog, given the correct fastener is used, in the provided holes, into the recommended base material.

In cold-formed steel framing, connectors such as holdowns, straps, angles and hurricane ties are often field-fabricated. However, field-fabricated connectors in general have not been designed and tested to determine their ultimate and allowable load capacity and are typically not code listed. Field-fabricated connectors consume valuable man-hours on the jobsite and typically do not have prepunched holes. Because of this, the installer may not be properly locating the fasteners to achieve the intended design load.

Simpson Strong-Tie connectors are the most thoroughly tested and evaluated products in the industry, value engineered for the lowest installed cost at the highest rated performance levels. Our connectors save the contractor time in the field, and when properly specified and installed, provide an easier installation, at a lower installed cost, and are warranted for accuracy of design. This should be taken in consideration when considering field-fabricated connectors.

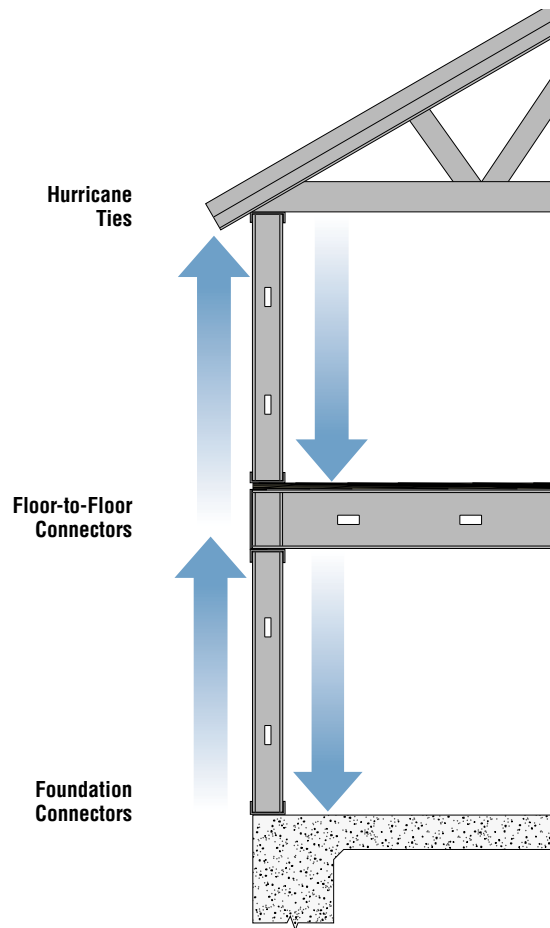

This shows a continuous load transfer path from the trusses to the foundation. A qualified Designer should ensure that correct quantities, fasteners and installation methods are used to achieve full design load values.



The Designer can also refer to our current *Wood Construction Connectors* catalog. Many of the connectors listed there may be used for cold-formed steel construction, using the screw values found in this catalog.

This catalog reflects changes in the allowable loads and configurations of some Simpson Strong-Tie Company Inc. products. This catalog is effective until December 31, 2011, and supersedes all information in all earlier publications, including catalogs, brochures, fliers, technical bulletins, etc. Use this edition as a current printed reference. Information on allowable loads and configurations is updated annually.

We post our catalogs on www.strongtie.com. Please visit our site, and sign up for any information updates. Allowable loads in this catalog are for the described specific applications of properly-installed products. Product modifications, improper loading or installation procedures, or deviations from recommended applications will affect connector allowable load-carrying capacities.



Every day we work hard to earn your business, blending the talents of our people with the quality of our products and services to exceed your expectations. This is our pledge to you.



Wood Construction Connectors

Includes specifications and installation instructions on wood-to-wood and wood-to-concrete structural connectors. Includes load tables and material specifications.

Anchoring and Fastening Systems for Concrete and Masonry

Includes application information, specifications and load values for anchoring adhesive and mechanical anchors, P.A.T. and carbide drill bits.

Quik Drive® Systems Catalog

A complete line of labor-saving auto-feed systems and specialty fasteners for a wide range of commercial and residential construction applications.

Strong-Wall® Shearwalls

All the information on our Strong-Wall shearwalls is now in one easy to use catalog: technical data, installation information, structural details and more. The catalog also features new solutions for two-story and balloon frame applications as well as an extensive section on braced frame requirements under the various building codes.

Anchor Tiedown Systems

This system is designed to provide the over-turning holddown capacity for multi-story commercial buildings. This holddown application is easy to specify, install and inspect.

High Wind Framing Connection Guide

Developed for designers and engineers as a companion to the AF&PA Wood Frame Construction Manual.

Code Compliant Repair and Protection Guide

Developed for building professionals to help explain products and techniques related to the installation of utilities in wood frame construction.

Strong Frame™ Ordinary Moment Frame

The Strong Frame Ordinary Moment Frame catalog contains complete information on the Strong Frame ordinary moment frame including product information, detail installation instructions and technical data. Performance data is available for engineered designs as well as prescriptive wall-bracing applications.

Simpson Strong-Tie Free CD-ROM

Our CD-ROM features our latest catalogs, fliers, technical bulletins, code reports, product list prices, UPC information, and the Simpson Strong-Tie Connector Selector program. It also includes the Drawing Library.



Home Office
5956 W. Las Positas Blvd.
Pleasanton, CA 94588
Tel: 925/560-9000
Fax: 925/847-1603

Northwest USA
5151 S. Airport Way
Stockton, CA 95206
Tel: 209/234-7775
Fax: 209/234-3868

Southwest USA
12246 Holly Street
Riverside, CA 92509
Tel: 714/871-8373
Fax: 951/369-2889

Northeast USA
2600 International St.
Columbus, OH 43228
Tel: 614/876-8060
Fax: 614/876-0636

Southeast USA
2221 Country Lane
McKinney, TX 75069
Tel: 972/542-0326
Fax: 972/542-5379

Quik Drive Factory
436 Calvert Drive
Gallatin, TN 37066
Tel: 888/487-7845
Fax: 615/451-9806

Eastern Canada
5 Kenview Boulevard
Brampton, ON L6T 5G5
Tel: 905/458-5538
Fax: 905/458-7274

Western Canada
11476 Kingston Street
Maple Ridge, B.C. V2X 0Y5
Tel: 604/465-0296
Fax: 604/465-0297

Simpson Strong-Tie Anchor Systems
136 Official Road
Addison, IL 60101
Tel: 630/543-2797
Fax: 630/543-7014

Specials Factories
Kent, WA
Eagan, MN

Distribution Centers
Enfield, CT
High Point, NC
Jacksonville, FL
Jessup, MD

International Facilities
Please visit our website for contact details.